

True System-on-Chip with Low Power RF Transceiver and 8051 MCU

Applications

- Wireless keyboard and mouse
- Wireless voice-quality audio
- CC2511Fx: USB dongles
- Remote controls
- Wireless sports and leisure equipment

- Point-of-sale systems
- Active RFID and asset tracking systems
- Home and building automation
- Low power telemetry
- 2.4 GHz ISM/SRD band systems

Product Description

The CC2510Fx/CC2511Fx is a low-cost true system-on-chip (SoC) device designed for low-power and low-voltage wireless communication applications. The CC2510Fx/CC2511Fx combines the excellent performance of the state-of-the-art RF transceiver CC2500 with an industry-standard enhanced 8051 MCU, 8/16/32 kB of in-system programmable flash memory, 1/2/4 kB of RAM and many other powerful features.

The CC2510Fx/CC2511Fx is available in six different versions: CC2510F8 and CC2511F8 with 8 kB of Flash and 1 kB of RAM, the CC2510F16 and CC2511F16 with 16 kB of Flash and 2 kB of RAM, and CC2510F32 and CC2511F32 with 32 kB of Flash and 4 kB of RAM. The CC2510Fx/CC2511Fx is highly suited for systems where very low power consumption is required. This is ensured by several advanced low-power operating modes. The CC2511Fx adds a full-speed USB interface to the feature set of the CC2510Fx. Interfacing to a PC using the USB interface is quick and easy, and the high data rate (12 Mbps) of the

USB interface avoids the bottlenecks of RS-232 or low-speed USB interfaces.

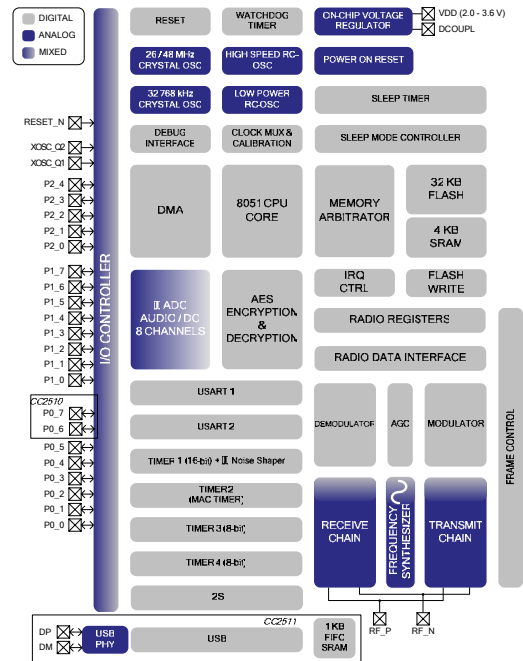

Key Features

- High performance and low power 8051 microcontroller core.
- High-performance CC2500 RF transceiver based on the market-leading CC2500
- Frequency band: 2.4 GHz
- 8/16/32 kB in-system programmable flash
- 1/2/4 kB RAM + 1 kB USB FIFO (CC2511Fx)
- Full-Speed USB Controller (CC2511Fx)
- I2S interface
- 8-14 bits ADC with up to eight inputs
- 128-bit AES security coprocessor
- Powerful DMA functionality
- Two USARTs
- 16-bit timer with configurable  $\Delta\Sigma$  mode
- Three 8-bit timers

- Hardware debug support
- 21 (CC2510Fx), 19 (CC2511Fx) GPIO pins
- Wide supply voltage range (2.0V – 3.6V)
- High sensitivity (–100 dBm at 10 kbps)
- Programmable data rate up to 500 kbps
- Low current consumption (RX: 22 mA, TX: 23 mA, with MCU running at 26 MHz)
- MCU current consumption 270 $\mu$ A/MHz
- Programmable output power up to 1 dBm for all supported frequencies
- Digital RSSI / LQI support
- Excellent receiver selectivity and blocking performance
- 0.3  $\mu$ A consumption in lowest power mode
- RoHS compliant 6x6mm QLP36 package

This data sheet contains preliminary data, and supplementary data will be published at a later date. Chipcon reserves the right to make changes at any time without notice in order to improve design and supply the best possible product. The product is not yet fully qualified at this point.

## Table of Contents

<b>1</b>	<b>ABBREVIATIONS</b> .....	<b>5</b>
<b>2</b>	<b>REFERENCES</b> .....	<b>6</b>
<b>3</b>	<b>REGISTER CONVENTIONS</b> .....	<b>6</b>
<b>4</b>	<b>FEATURES (CONTINUED FROM FRONT PAGE)</b> .....	<b>8</b>
4.1	HIGH-PERFORMANCE AND LOW-POWER 8051-COMPATIBLE MICROCONTROLLER .....	8
4.2	8/16/32 kB NON-VOLATILE PROGRAM MEMORY AND 1/2/4 kB DATA MEMORY .....	8
4.3	FULL-SPEED USB CONTROLLER ( <b>CC2511Fx</b> ) .....	8
4.4	I2S INTERFACE.....	8
4.5	HARDWARE AES ENCRYPTION/DECRYPTION.....	8
4.6	PERIPHERAL FEATURES .....	8
4.7	LOW POWER.....	8
4.8	2.4 GHz RADIO WITH BASEBAND MODEM .....	9
<b>5</b>	<b>ABSOLUTE MAXIMUM RATINGS</b> .....	<b>10</b>
<b>6</b>	<b>OPERATING CONDITIONS</b> .....	<b>10</b>
6.1	<b>CC2510Fx</b> OPERATING CONDITIONS .....	10
6.2	<b>CC2511Fx</b> OPERATING CONDITIONS .....	10
<b>7</b>	<b>ELECTRICAL SPECIFICATIONS</b> .....	<b>11</b>
7.1	GENERAL CHARACTERISTICS .....	12
7.2	RF RECEIVE SECTION.....	13
7.3	RF TRANSMIT SECTION.....	14
7.4	26/48 MHz CRYSTAL OSCILLATOR.....	15
7.5	32.768 kHz CRYSTAL OSCILLATOR .....	15
7.6	LOW POWER RC OSCILLATOR.....	16
7.7	HIGH SPEED RC OSCILLATOR .....	16
7.8	FREQUENCY SYNTHESIZER CHARACTERISTICS.....	17
7.9	ANALOG TEMPERATURE SENSOR .....	17
7.10	8-14 BIT ADC.....	18
7.11	CONTROL AC CHARACTERISTICS .....	19
7.12	SPI AC CHARACTERISTICS.....	20
7.13	DEBUG INTERFACE AC CHARACTERISTICS .....	21
7.14	PORT OUTPUTS AC CHARACTERISTICS .....	21
7.15	TIMER INPUTS AC CHARACTERISTICS .....	22
7.16	DC CHARACTERISTICS .....	22
<b>8</b>	<b>PIN AND I/O PORT CONFIGURATION</b> .....	<b>23</b>
<b>9</b>	<b>CIRCUIT DESCRIPTION</b> .....	<b>27</b>
9.1	CPU AND PERIPHERALS .....	28
9.2	RADIO .....	29
<b>10</b>	<b>POWER CONTROL</b> .....	<b>30</b>
<b>11</b>	<b>APPLICATION CIRCUIT</b> .....	<b>31</b>
11.1	BIAS RESISTOR .....	31
11.2	BALUN AND RF MATCHING .....	31
11.3	CRYSTAL.....	31
11.4	USB ( <b>CC2511Fx</b> ) .....	31
11.5	POWER SUPPLY DECOUPLING.....	31
<b>12</b>	<b>8051 CPU</b> .....	<b>35</b>
12.1	8051 CPU INTRODUCTION .....	35
12.2	RESET.....	35
12.3	MEMORY.....	35
12.4	SFR REGISTERS.....	39

12.5	CPU REGISTERS .....	42
12.6	INSTRUCTION SET SUMMARY .....	44
12.7	INTERRUPTS .....	49
12.8	OSCILLATORS AND CLOCKS .....	60
12.9	DEBUG INTERFACE .....	60
12.10	RAM .....	64
12.11	FLASH MEMORY .....	64
12.12	MEMORY ARBITER .....	64
<b>13</b>	<b>PERIPHERALS.....</b>	<b>66</b>
13.1	I/O PORTS .....	66
13.2	DMA CONTROLLER .....	84
13.3	16-BIT TIMER, TIMER 1 .....	97
13.4	MAC TIMER (TIMER 2) .....	111
13.5	SLEEP TIMER .....	113
13.6	8-BIT TIMER 3 AND TIMER 4 .....	116
13.7	ADC.....	127
13.8	RANDOM NUMBER GENERATOR.....	133
13.9	AES COPROCESSOR .....	135
13.10	POWER MANAGEMENT .....	140
13.11	POWER ON RESET .....	144
13.12	WATCHDOG TIMER.....	145
13.13	USART .....	147
13.14	I2S .....	158
13.15	USB CONTROLLER .....	166
13.16	FLASH CONTROLLER .....	184
<b>14</b>	<b>CRYSTAL OSCILLATOR .....</b>	<b>190</b>
14.1	<b>CC2510Fx</b> CRYSTAL OSCILLATOR .....	190
14.2	<b>CC2511Fx</b> CRYSTAL OSCILLATOR .....	190
<b>15</b>	<b>RADIO.....</b>	<b>191</b>
15.1	COMMAND STROBES .....	191
15.2	RADIO REGISTERS .....	193
15.3	INTERRUPTS .....	193
15.4	TX/RX DATA TRANSFER .....	195
15.5	DATA RATE PROGRAMMING .....	196
15.6	RECEIVER CHANNEL FILTER BANDWIDTH .....	197
15.7	DEMODULATOR, SYMBOL SYNCHRONIZER AND DATA DECISION.....	197
15.8	PACKET HANDLING HARDWARE SUPPORT .....	198
15.9	MODULATION FORMATS .....	202
15.10	RECEIVED SIGNAL QUALIFIERS AND LINK QUALITY INFORMATION.....	203
15.11	FORWARD ERROR CORRECTION WITH INTERLEAVING.....	207
15.12	RADIO CONTROL .....	208
15.13	FREQUENCY PROGRAMMING .....	211
15.14	VCO.....	211
15.15	OUTPUT POWER PROGRAMMING .....	212
15.16	SELECTIVITY GRAPHS .....	213
15.17	ANTENNA INTERFACE.....	216
15.18	SYSTEM CONSIDERATIONS AND GUIDELINES .....	216
15.19	RADIO REGISTERS .....	219
<b>16</b>	<b>VOLTAGE REGULATORS .....</b>	<b>241</b>
16.1	VOLTAGE REGULATOR POWER-ON.....	241
<b>17</b>	<b>RADIO TEST OUTPUT SIGNALS.....</b>	<b>241</b>
<b>18</b>	<b>EVALUATION SOFTWARE .....</b>	<b>243</b>
<b>19</b>	<b>REGISTER OVERVIEW .....</b>	<b>244</b>
<b>20</b>	<b>PACKAGE DESCRIPTION (QLP 36).....</b>	<b>247</b>

20.1	RECOMMENDED PCB LAYOUT FOR PACKAGE (QLP 36).....	248
20.2	PACKAGE THERMAL PROPERTIES.....	248
20.3	SOLDERING INFORMATION.....	248
20.4	TRAY SPECIFICATION.....	248
20.5	CARRIER TAPE AND REEL SPECIFICATION.....	249
<b>21</b>	<b>ORDERING INFORMATION.....</b>	<b>249</b>
<b>22</b>	<b>GENERAL INFORMATION.....</b>	<b>250</b>
22.1	DOCUMENT HISTORY.....	250
22.2	PRODUCT STATUS DEFINITIONS.....	250
<b>23</b>	<b>ADDRESS INFORMATION.....</b>	<b>251</b>
<b>24</b>	<b>TI WORLDWIDE TECHNICAL SUPPORT.....</b>	<b>251</b>

## 1 Abbreviations

ADC	Analog to Digital Converter	ISM	Industrial, Scientific and Medical
AES	Advanced Encryption Standard	ITU-T	International Telecommunication Union – Telecommunication Standardization Sector
AGC	Automatic Gain Control		
ARIB	Association of Radio Industries and Businesses	IV	Initialization Vector
BCD	Binary Coded Decimal	kbps	kilo bits per second
BER	Bit Error Rate	KB	1024 bytes
CBC	Cipher Block Chaining	LFSR	Linear Feedback Shift Register
CBC-MAC	Cipher Block Chaining Message Authentication Code	LNA	Low-Noise Amplifier
CCA	Clear Channel Assessment	LO	Local Oscillator
CCM	Counter mode + CBC-MAC	LQI	Link Quality Indication
CFB	Cipher Feedback	LSB	Least Significant Bit / Byte
CFR	Code of Federal Regulations	MAC	Message Authentication Code
CMOS	Complementary Metal Oxide Semiconductor	MCU	Micro Controller Unit
CPU	Central Processing Unit	MSB	Most Significant Byte
CRC	Cyclic Redundancy Check	NA	Not Available
CTR	Counter mode (encryption)	NC	Not Connected
CW	Continuous Wave	OFB	Output Feedback (encryption)
DAC	Digital to Analogue Converter	PA	Power Amplifier
DMA	Direct Memory Access	PCB	Printed Circuit Board
DSM	Delta Sigma Modulator	PER	Packet Error Rate
ECB	Electronic Code Book	PLL	Phase Locked Loop
EM	Evaluation Module	PM{0-3}	Power Mode 0-3
ENOB	Effective Number Of Bits	PMC	Power Management Controller
EP{0-5}	USB Endpoint 0-5	POR	Power On Reset
ESD	Electro Static Discharge	PWM	Pulse Width Modulator
ESR	Equivalent Series Resistance	QLP	Quad Leadless Package
ETSI	European Telecommunications Standards Institute	RAM	Random Access Memory
FCC	Federal Communications Commission	RBW	Resolution Bandwidth
FFCTRL	FIFO and Frame Control	RCOSC	RC Oscillator
FIFO	First In First Out	RF	Radio Frequency
HSSD	High Speed Serial Debug	RoHS	Restriction on Hazardous Substances
I2S	Inter-IC Sound	RSSI	Receive Signal Strength Indicator
I/O	Input / Output	RTC	Real-Time Clock
I/Q	In-phase / Quadrature-phase	RX	Receive
IEEE	Institute of Electrical and Electronics Engineers	SCK	Serial Clock
IF	Intermediate Frequency	SFD	Start of Frame Delimiter
IOC	I/O Controller	SFR	Special Function Register
		SINAD	Signal-to-noise and distortion ratio
		SOF	Start Of Frame
		SPI	Serial Peripheral Interface

SRAM	Static Random Access Memory	USART	Universal Synchronous/Asynchronous Receiver/Transmitter
ST	Sleep Timer	USB	Universal Serial Bus
T/R	Transmit / Receive	VCO	Voltage Controlled Oscillator
TBD	To Be Decided / To Be Defined	VGA	Variable Gain Amplifier
TX	Transmit	WDT	Watchdog Timer
UART	Universal Asynchronous Receiver/Transmitter	XOSC	Crystal Oscillator

## 2 References

- [1] NIST FIPS Pub 197: Advanced Encryption Standard (AES), Federal Information Processing Standards Publication 197, US Department of Commerce/N.I.S.T., November 26, 2001. Available from the NIST website.  
<http://csrc.nist.gov/publications/fips/fips197/fips-197.pdf>
- [2] Universal Serial Bus Revision 2.0 Specification. Available from the USB Implementors Forum website.  
<http://www.usb.org/developers/docs/>
- [3] I<sup>2</sup>S bus specification, Philips Semiconductors, Available from the Philips Semiconductors website.  
[http://www.semiconductors.philips.com/acrobat\\_download/various/I2SBUS.pdf](http://www.semiconductors.philips.com/acrobat_download/various/I2SBUS.pdf)
- [4] IEEE Std 1241-2000, IEEE standard for terminology and test methods for analog-to-digital converters.

## 3 Register conventions

Each SFR register is described in a separate table. The table heading is given in the following format:

**REGISTER NAME (SFR Address) - Register Description.**

Each RF register is described in a separate table. The table heading is given in the following format:

**XDATA Address: REGISTER NAME - Register Description**

All register descriptions include for each register bit a symbol denoted R/W describing the accessibility of the bit. The register values are always given in binary notation unless prefixed by '0x' which indicates hexadecimal notation.

<b>Symbol</b>	<b>Access Mode</b>
R/W	Read/write
R	Read only
R0	Read as 0
R1	Read as 1
W	Write only
W0	Write as 0
W1	Write as 1
H0	Hardware clear
H1	Hardware set

**Table 1: Register bit conventions**

## 4 Features (continued from front page)

### 4.1 High-Performance and Low-Power 8051-Compatible Microcontroller

- Optimized 8051 core which typically gives 8x the performance of a standard 8051
- Dual data pointers
- In-circuit interactive debugging is supported for the IAR Embedded Workbench through a simple two-wire serial interface

### 4.2 8/16/32 kB Non-volatile Program Memory and 1/2/4 kB Data Memory

- 8, 16 or 32 kB of non-volatile Flash memory, in-system programmable through a simple two-wire interface or by the 8051 core
- Worst case flash memory endurance: 1000 write/erase cycles (applies per bit cell).
- Programmable read and write lock of portions of Flash memory for software security
- 1, 2 or 4 kB of internal SRAM

### 4.3 Full-Speed USB Controller (CC2511Fx)

- 5 bi-directional endpoints in addition to control endpoint 0
- Full-Speed, 12 Mbps transfer rate.
- Support for Bulk, Interrupt and Isochronous endpoints
- 1024 bytes of dedicated endpoint FIFO memory.
- 8 – 512 byte data packet size supported
- Configurable FIFO size for IN and OUT direction of endpoint

### 4.4 I2S Interface

- Industry standard I2S interface for transfer of digital audio data
- Full duplex
- Mono and stereo support
- Configurable sample rate and sample size

- Support for  $\mu$ -law compression and expansion
- Typically used to connect to external DAC or ADC.

### 4.5 Hardware AES Encryption/Decryption

- 128-bit AES supported in hardware coprocessor

### 4.6 Peripheral Features

- Powerful DMA Controller
- Power On Reset
- Battery monitor
- Eight channel, 8-14 bit ADC
- Programmable watchdog timer
- Real time clock with 32.768 kHz crystal oscillator
- Four timers: one general 16-bit timer, two general 8-bit timers, one MAC timer. The 16-bit timer can also be used in Delta-Sigma Modulator (DSM) mode. This allows the timer to produce a high quality audio output signal that only requires a low-cost passive external filter.
- Two programmable USARTs for master/slave SPI or UART operation
- Up to 21 configurable general-purpose digital I/O-pins (CC2511Fx has 19 general-purpose digital I/O-pins)
- Random number generator

### 4.7 Low Power

- Four flexible power modes for reduced power consumption
- Only 0.5  $\mu$ A current consumption in standby mode, where external interrupts or the real-time counter can wake up the system
- 0.3  $\mu$ A current consumption in power down mode, where external interrupts can wake up the system
- System can wake up on external interrupt or real-time counter event



- Low-power fully static CMOS design
- System clock source can be 13 MHz RC oscillator or 26/48 MHz crystal oscillator. The 26/48 MHz oscillator is used when the radio is active.
- Optional clock source for ultra-low power operation can be either a low-power RC oscillator or an optional 32.768 kHz crystal oscillator
- Very fast transition from sleep modes to active enable ultra low average power consumption in low duty-cycle systems

#### **4.8 2.4 GHz Radio with baseband modem**

- Based on the industry leading ***CC2500*** radio core
- Very few external components: Totally on-chip frequency synthesizer, no external filters or RF switch needed
- Flexible support for packet oriented systems: On chip support for sync word detection, address check, flexible packet length and automatic CRC handling.

- Supports use of DMA for both RX and TX. Resulting in minimal CPU interference even on high data rates.
- Programmable channel filter bandwidth
- 2-FSK, GFSK and MSK supported.
- Optional automatic whitening and de-whitening of data
- Support for asynchronous transparent receive/transmit mode for backwards compatibility with existing radio communication protocols
- Programmable Carrier Sense indicator
- Programmable Preamble Quality Indicator for detecting preambles and improved protection against sync word detection in random noise
- Support for automatic Clear Channel Assessment (CCA) before transmitting (for listen-before-talk systems)
- Support for per-package Link Quality Indication

## 5 Absolute Maximum Ratings

Under no circumstances must the absolute maximum ratings given in Table 2 be violated. Stress exceeding one or more of the limiting values may cause permanent damage to the device.

Parameter	Min	Max	Units	Condition
Supply voltage	-0.3	3.6	V	All supply pins must have the same voltage
Voltage on any digital pin	-0.3	VDD+0.3, max 3.6	V	
Input RF level		+10	dBm	
Storage temperature range	-50	150	°C	Device not programmed
Solder reflow temperature		260	°C	According to IPC/JEDEC J-STD-020C

Table 2: Absolute Maximum Ratings

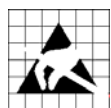

**Caution!** ESD sensitive device. Precaution should be used when handling the device in order to prevent permanent damage.

## 6 Operating Conditions

### 6.1 CC2510Fx Operating conditions

The operating conditions for *CC2510Fx* are listed Table 3 in below.

Parameter	Min	Max	Unit	Condition
Operating ambient temperature, T <sub>A</sub>	-40	85	°C	
Operating supply voltage	2.0	3.6	V	All supply pins must have the same voltage

Table 3: Operating Conditions *CC2510Fx*

### 6.2 CC2511Fx Operating conditions

The operating conditions for *CC2511Fx* are listed Table 4 in below.

Parameter	Min	Max	Unit	Condition
Operating ambient temperature, T <sub>A</sub>	0	80	°C	
Operating supply voltage	3.0	3.6	V	

Table 4 Operating Conditions *CC2511Fx*

## 7 Electrical Specifications

T<sub>A</sub>=25°C, VDD=3.0V if nothing else stated. Measured on Chipcon's **CC2510Fx** EM reference design.

Parameter	Min	Typ	Max	Unit	Condition
Power On Reset Voltage		1.1		V	Monitors the unregulated supply
<b>Current Consumption</b>					
MCU Active Mode, static		500		μA	Digital regulator on, High Speed RCOSC running. No radio, crystals, or peripherals.
MCU Active Mode, dynamic		270		μA/MHz	Digital regulator on, High Speed RCOSC running. No radio, crystals, or peripherals.
MCU Active Mode, highest speed		7.5		mA	<b>CC2510Fx:</b> MCU running at full speed (26 MHz), XOSC running. No peripherals.
		7.0			<b>CC2511Fx:</b> MCU running at full speed (24 MHz), XOSC running. No peripherals.
MCU Active and RX Mode, -100 dBm input		20		mA	<b>CC2510Fx:</b> MCU running at full speed (26 MHz), XOSC running, radio in RX mode. No peripherals.
		18			<b>CC2511Fx:</b> MCU running at full speed (24 MHz), XOSC running, radio in RX mode. No peripherals.
MCU Active and RX Mode, -30 dBm input		18		mA	<b>CC2510Fx:</b> MCU running at full speed (26 MHz), XOSC running, radio in RX mode. No peripherals.
		16			<b>CC2511Fx:</b> MCU running at full speed (24 MHz), XOSC running, radio in RX mode. No peripherals.
MCU Active and TX Mode, 0dBm		23		mA	<b>CC2510Fx:</b> MCU running at full speed (26 MHz), XOSC running, radio in TX mode. No peripherals.
		21			<b>CC2511Fx:</b> MCU running at full speed (24 MHz), XOSC running, radio in TX mode. No peripherals.
Power mode 1		187		μA	Digital regulator on, High Speed RCOSC and crystal oscillator off. 32.768kHz XOSC, POR and ST active. RAM retention.
Power mode 2		0.5		μA	Digital regulator off, High Speed RCOSC and crystal oscillator off. 32.768kHz XOSC, POR and ST active. RAM retention.
Power mode 3		0.3		μA	No clocks. RAM retention. Power On Reset active.
<b>Peripheral Current Consumption</b>					
					Add to the figures above if the peripheral unit is activated
Timer 1		10		μA/MHz	When enabled
Timer 2		10		μA/MHz	When enabled
Timer 3		10		μA/MHz	When enabled
Timer 4		10		μA/MHz	When enabled
Sleep Timer		0.5		μA	Including low-power RC oscillator or 32.768kHz XOSC
AES		50		μA/MHz	When encrypting/decrypting
ADC		0.9		mA	When converting
USART1 / USART2		12		μA/MHz	For each USART in use. Not including current for driving I/O pins.
DMA		30		μA/MHz	When operating, not including current for memory access
Flash write		3		mA	

**Table 5: Electrical Specifications**

## 7.1 General Characteristics

T<sub>A</sub>=25°C, VDD=3.0V if nothing else stated.

Parameter	Min	Typ	Max	Unit	Condition/Note
<b>Wake-Up and Timing</b>					
PM1 → PM0		31		ns	Digital regulator on, High Speed RCOSC or crystal oscillator running. Entry from PM1 to PM0 takes one clock period.
PM1 → PM0		10	13	μs	Digital regulator on, High Speed RCOSC and crystal oscillator off. Start-up of High Speed RCOSC.
PM1 → PM0 RX/TX		195		μs	Digital regulator on. Crystal oscillator off. Start-up of Crystal oscillator and RF TX/RX begins.
PM2/PM3 → PM0		50		μs	Digital regulator off, High Speed RCOSC and crystal oscillator off. Start-up of regulator and High Speed RCOSC.
<b>Radio part</b>					
Frequency range	2400		2483.5	MHz	
Data rate	1.2		500	kbps	2-FSK
	1.2		250	kbps	GFSK and OOK
	26		500	kbps	(Shaped) MSK (also known as differential offset QPSK)
					Optional Manchester encoding (halves the data rate).

**Table 6: General Characteristics**

## 7.2 RF Receive Section

T<sub>A</sub>=25°C, VDD=3.0V if nothing else stated. Measured on Chipcon's *CC2510Fx* EM reference design.

Parameter	Min	Typ	Max	Unit	Condition/Note
Digital channel filter bandwidth	58		812	kHz	User programmable. The bandwidth limits are proportional to crystal frequency (given values assume a 26.0 MHz crystal).
<b>2.4 kbps data rate, current optimized</b> , MDMCFG2.DEM_DCFILT_OFF = 1 (2-FSK, 1% packet error rate, 20 bytes packet length, 203 kHz digital channel filter bandwidth)					
Receiver sensitivity		-105		dBm	<i>CC2510Fx</i> : The typical current consumption is in this case 17.0 mA at sensitivity limit.
		-107			<i>CC2511Fx</i> : The typical current consumption is in this case 17.0 mA at sensitivity limit.
Saturation		-13		dBm	
Adjacent channel rejection		23		dB	Desired channel 3 dB above the sensitivity limit. 250 kHz channel spacing
Alternate channel rejection		31		dB	Desired channel 3 dB above the sensitivity limit. 250 kHz channel spacing
					See Figure 52 for plot of selectivity versus frequency offset
<b>10 kbps data rate, current optimized</b> , MDMCFG2.DEM_DCFILT_OFF = 1 (2-FSK, 1% packet error rate, 20 bytes packet length, 232 kHz digital channel filter bandwidth)					
Receiver sensitivity		-98		dBm	The sensitivity can be improved to typically -100 dBm by setting MDMCFG2.DEM_DCFILT_OFF = 0. The typical current consumption is in this case 17.3 mA at sensitivity limit.
Saturation		-9		dBm	
Adjacent channel rejection		18		dB	Desired channel 3 dB above the sensitivity limit. 250 kHz channel spacing
Alternate channel rejection		25		dB	Desired channel 3 dB above the sensitivity limit. 250 kHz channel spacing
					See Figure 53 for plot of selectivity versus frequency offset
<b>250 kbps data rate</b> , MDMCFG2.DEM_DCFILT_OFF = 0 (MSK, 1% packet error rate, 20 bytes packet length, 600 kHz digital channel filter bandwidth)					
Receiver sensitivity		-91		dBm	<i>CC2510Fx</i>
		-90			<i>CC2511Fx</i>
Saturation		-13		dBm	
Adjacent channel rejection		21		dB	Desired channel 3 dB above the sensitivity limit. 750 kHz channel spacing
Alternate channel rejection		30		dB	Desired channel 3 dB above the sensitivity limit. 750 kHz channel spacing
					See Figure 54 for plot of selectivity versus frequency offset
<b>250 kbps data rate current optimized</b> , MDMCFG2.DEM_DCFILT_OFF = 1 (MSK, 1% packet error rate, 20 bytes packet length, 540 kHz digital channel filter bandwidth)					
Receiver sensitivity		-86		dBm	
Saturation		-13		dBm	
Adjacent channel rejection		21		dB	Desired channel 3 dB above the sensitivity limit. 750 kHz channel spacing
Alternate channel rejection		30		dB	Desired channel 3 dB above the sensitivity limit. 750 kHz channel spacing
					See Figure 55 for plot of selectivity versus frequency offset
<b>500 kbps data rate</b> , MDMCFG2.DEM_DCFILT_OFF = 0 (MSK, 1% packet error rate, 20 bytes packet length, 812 kHz digital channel filter bandwidth)					
Receiver sensitivity		-81		dBm	
Saturation		-18		dBm	
Adjacent channel rejection		14		dB	Desired channel 3 dB above the sensitivity limit. 1 MHz channel spacing

Parameter	Min	Typ	Max	Unit	Condition/Note
Alternate channel rejection		25		dB	Desired channel 3 dB above the sensitivity limit. 1 MHz channel spacing
					See Figure 56 for plot of selectivity versus frequency offset
<b>General</b>					
Selectivity at ±10 MHz offset		47		dB	Desired channel at -80 dBm. Compliant with ETSI EN 300 440 class 2 receiver requirements.
Selectivity at ±20 MHz offset		52		dB	Desired channel at -80 dBm. Compliant with ETSI EN 300 440 class 2 receiver requirements.
Selectivity at ±50 MHz offset		54		dB	Desired channel at -80 dBm. Compliant with ETSI EN 300 440 class 2 receiver requirements.
Spurious emissions 25 MHz – 1 GHz Above 1 GHz			-57 -47	dBm dBm	

**Table 7: RF Receive Section**

### 7.3 RF Transmit Section

T<sub>A</sub>=25°C, VDD=3.0V if nothing else stated. Measured on Chipcon's *CC2510Fx* EM reference design.

Parameter	Min	Typ	Max	Unit	Condition/Note
Differential load impedance		80 + j74		Ω	Differential impedance as seen from the RF-port (RF_P and RF_N) towards the antenna. Follow the CC2510Fx EM reference design available from Chipcon's website.
Output power, highest setting		+1		dBm	Output power is programmable and is available across the entire frequency band Delivered to 50 Ω single-ended load via Chipcon reference RF matching network.
Output power, lowest setting		-30		dBm	Output power is programmable and is available across the entire frequency band Delivered to 50 Ω single-ended load via Chipcon reference RF matching network.
Spurious emissions 25 MHz – 1 GHz Above 1 GHz			-57 -47	dBm dBm	

**Table 8: RF Transmit Parameters**

## 7.4 26/48 MHz Crystal Oscillator

### 7.4.1 CC2510 Crystal Oscillator (26 MHz)

T<sub>A</sub>=25°C, VDD=3.0V if nothing else is stated.

Parameter	Min	Typ	Max	Unit	Condition/Note
Crystal frequency	24	26	27	MHz	
Crystal frequency accuracy requirement		±40		ppm	This is the total tolerance including a) initial tolerance, b) ageing and c) temperature dependence. The acceptable crystal tolerance depends on RF frequency and channel spacing / bandwidth.
Crystal shunt cap	1	5	7	pF	
Load capacitance	10	13	20	pF	
ESR	6		100	Ω	
Start-up time		212		us	

**Table 9: 26 MHz Crystal Oscillator Parameters (CC2510)**

### 7.4.2 CC2511Fx Crystal Oscillator (48 MHz)

T<sub>A</sub>=25°C, VDD=3.0V if nothing else is stated.

Parameter	Min	Typ	Max	Unit	Condition/Note
Crystal frequency	48	48	48	MHz	
Crystal frequency accuracy requirement		±40		ppm	This is the total tolerance including a) initial tolerance, b) ageing and c) temperature dependence. The acceptable crystal tolerance depends on RF frequency and channel spacing / bandwidth.
Crystal shunt cap	2	3	7	pF	
Load capacitance	12	13	14	pF	
ESR		30	60	Ω	
Start-up time		628		us	

**Table 10: 48 MHz Crystal Oscillator Parameters (CC2511Fx)**

## 7.5 32.768 kHz Crystal Oscillator

T<sub>A</sub> =25°C, VDD=3.0V if nothing else is stated.

Parameter	Min	Typ	Max	Unit	Condition/Note
Crystal frequency		32.768		kHz	
Crystal frequency accuracy requirement				ppm	
ESR		40	130	Ω	
Crystal shunt cap		0.9	2.0	pF	
Load capacitance		12	16	pF	
Start-up time			450	ms	

**Table 11: 32.768 kHz Crystal Oscillator Parameters**

## 7.6 Low Power RC Oscillator

T<sub>A</sub>=25°C, VDD=3.0V if nothing else is stated.

Parameter	Min	Typ	Max	Unit	Condition/Note
Calibrated frequency	34.6	34.7	36	kHz	Calibrated RC Oscillator frequency is XTAL frequency divided by 750
Frequency accuracy after calibration			+0.3 -10	%	
Temperature coefficient		+0.4		% / °C	Frequency drift when temperature changes after calibration
Supply voltage coefficient		+3		% / V	Frequency drift when supply voltage changes after calibration
Initial calibration time		2		ms	When the RC Oscillator is enabled, calibration is continuously done in the background as long as the crystal oscillator is running.
Wake-up period	58μ		59650	Seconds	Programmable, dependent on XTAL frequency

**Table 12: Low Power RC Oscillator parameters**

## 7.7 High Speed RC Oscillator

T<sub>A</sub>=25°C, VDD=3.0V if nothing else is stated.

Parameter	Min	Typ	Max	Unit	Condition/Note
Frequency		13		MHz	Calibrated High Speed RC Oscillator frequency is XTAL frequency multiplied by 1/2
Uncalibrated frequency accuracy		±15		%	
Calibrated frequency accuracy			±1	%	
Start-up time			10	μs	
Temperature coefficient			-325	ppm / °C	Frequency drift when temperature changes after calibration
Supply voltage coefficient			28	ppm / V	Frequency drift when supply voltage changes after calibration
Initial calibration time		50		μs	When the High Speed RC Oscillator is enabled, calibration is continuously done in the background as long as the crystal oscillator is running.

**Table 13: High Speed RC Oscillator parameters**



## 7.8 Frequency Synthesizer Characteristics

T<sub>A</sub>=25°C, VDD=3.0V if nothing else stated. Measured on Chipcon's *CC2510Fx* EM reference design.

Parameter	Min	Typ	Max	Unit	Condition/Note
Programmed frequency resolution	397	$F_{XOSC}/2^{16}$	412	Hz	26-27 MHz crystal.
Synthesizer frequency tolerance		±40		ppm	Given by crystal used. Required accuracy (including temperature and aging) depends on frequency band and channel bandwidth / spacing.
RF carrier phase noise		-78		dBc/Hz	@ 50 kHz offset from carrier
RF carrier phase noise		-78		dBc/Hz	@ 100 kHz offset from carrier
RF carrier phase noise		-81		dBc/Hz	@ 200 kHz offset from carrier
RF carrier phase noise		-90		dBc/Hz	@ 500 kHz offset from carrier
RF carrier phase noise		-100		dBc/Hz	@ 1 MHz offset from carrier
RF carrier phase noise		-108		dBc/Hz	@ 2 MHz offset from carrier
RF carrier phase noise		-116		dBc/Hz	@ 5 MHz offset from carrier
RF carrier phase noise		-127		dBc/Hz	@ 10 MHz offset from carrier
PLL turn-on / hop time		90		µs	Time from leaving the IDLE state until arriving in the RX, FSTXON or TX state, when not performing calibration. Crystal oscillator running.
PLL RX/TX and TX/RX settling time		10		µs	Settling time for the 1xIF frequency step from RX to TX, and vice versa.
PLL calibration time		18739		XOSC cycles	Calibration can be initiated manually, or automatically before entering or after leaving RX/TX.
	0.69	0.72	0.72	ms	Min/typ/max time is for 27/26/26 MHz crystal frequency.

**Table 14: Frequency Synthesizer Parameters**

## 7.9 Analog Temperature Sensor

T<sub>A</sub>=25°C, VDD=3.0V if nothing else stated. Measured on Chipcon's *CC2510Fx* EM reference design.

Parameter	Min	Typ	Max	Unit	Condition/Note
Output voltage at -40°C		0.660		V	
Output voltage at 0°C		0.755		V	
Output voltage at +40°C		0.859		V	
Output voltage at +80°C		0.958		V	
Output voltage at +120°C		1.056		V	
Temperature coefficient		2.54		mV/°C	Fitted from -20°C to +80°C
Error in calculated temperature, calibrated		± 2		°C	From -20°C to +80°C when using 2.54mV / °C, after 1-point calibration at room temperature
Current consumption increase when enabled		0.3		mA	

**Table 15: Analog Temperature Sensor Parameters**

## 7.10 8-14 bit ADC

T<sub>A</sub>=25°C, VDD=3.0V if nothing else stated. The numbers given here are based on tests performed in accordance to the IEEE Std 1241-2000 [4].

Parameter	Min	Typ	Max	Unit	Condition/Note
Input voltage	0		AVDD	V	AVDD is voltage on AVDD pin
External reference voltage	0		AVDD	V	AVDD is voltage on AVDD pin
External reference voltage differential	0		AVDD	V	AVDD is voltage on AVDD pin
Number of bits (ENOB)	7		13	bits	The ADC is a delta-sigma. Effective resolution depends on sample rate used. Differential input signal and reference assumed.
Offset	-	-	-		Offset should be measured by sampling internal AGND <sup>1</sup> .
Conversion time	18		122	μs	CC2510 using 26 MHz system clock.
	20		132		CC2511Fx using 24 MHz system clock.
Differential nonlinearity (DNL) <sup>3</sup>		±0.3		LSB	8-bits setting
Integral nonlinearity (INL) <sup>3</sup>		±0.8		LSB	8-bits setting
SINAD <sup>2 3</sup> (sine input)		45		dB	8-bits setting
		56		dB	10-bits setting
		66		dB	12-bits setting
		75		dB	14-bits setting

**Table 16: 8-14 bit ADC Characteristics**

<sup>1</sup> The offset value depends on several factors as: mode of operation, temperature, voltage, noise, reference etc. In order to sample with high accuracy, the DC value of internal AGND and AVDD should be measured before starting the wanted sampling sequence. Thus, knowing the statistical nonlinearity and effective number of bits, the correct sample value can easily be calculated.

<sup>2</sup> The calculation assumes a differential input signal and a correlated differential reference.

<sup>3</sup> DNL, INL and SINAD are measured using dynamic characterisation methods by applying a sine wave input at P0.0 with AVDD\_SOC as reference.

### 7.11 Control AC Characteristics

T<sub>A</sub>=85°C, VDD=3.0V if nothing else stated. Measured on Chipcon's *CC2510Fx* EM reference design.

Parameter	Min	Typ	Max	Unit	Condition/Note
System clock, f <sub>SYSCLK</sub>			26	MHz	<i>CC2510Fx</i> : Applies when 26 MHz crystal oscillator is used. Maximum system clock is 13 MHz when high speed RC oscillator is used.
t <sub>SYSCLK</sub> = 1/ f <sub>SYSCLK</sub>		24	24	MHz	<i>CC2511Fx</i> : Applies when 48 MHz crystal oscillator is used. Maximum system clock is 13 MHz when high speed RC oscillator is used.
RESET_N low width	2.5			ns	See item 1, Figure 1. This is the shortest pulse that is guaranteed to be recognized as a reset pin request.
Interrupt pulse width	t <sub>SYSCLK</sub>				See item 2, Figure 1. This is the shortest pulse that is guaranteed to be recognized as an interrupt request. In PM2/3 the internal synchronizers are bypassed so this requirement does not apply in PM2/3.

Table 17: Control Inputs AC Characteristics

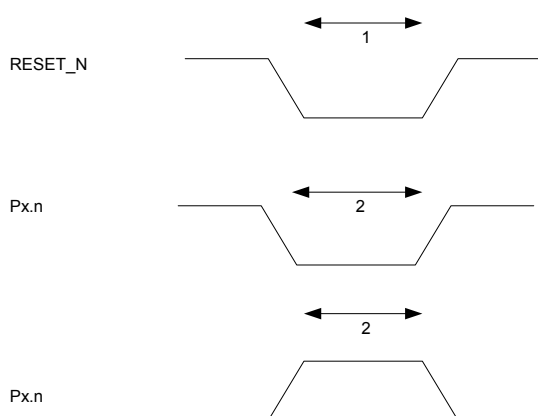

Figure 1: Control Inputs AC Characteristics

7.12 SPI AC Characteristics

T<sub>A</sub>=85°C, VDD=3.0V if nothing else stated. Measured on Chipcon's CC2510Fx EM reference design.

Parameter	Min	Typ	Max	Unit	Condition/Note
SCK period		See section 13.13.3		ns	Master. See item 1 Figure 2
SCK duty cycle		50%			Master.
SSN low to SCK	2*t <sub>SYSCLK</sub>				See item 5 Figure 2
SCK to SSN high	30			ns	See item 6 Figure 2
MISO setup	10			ns	Master. See item 2 Figure 2
MISO hold	10			ns	Master. See item 3 Figure 2
SCK to MOSI			25	ns	Master. See item 4 Figure 2, load = 10 pF
SCK period	100			ns	Slave. See item 1 Figure 2
SCK duty cycle		50%			Slave.
MOSI setup	10			ns	Slave. See item 2 Figure 2
MOSI hold	10			ns	Slave. See item 3 Figure 2
SCK to MISO			25	ns	Slave. See item 4 Figure 2, load = 10 pF

Table 18: SPI AC Characteristics

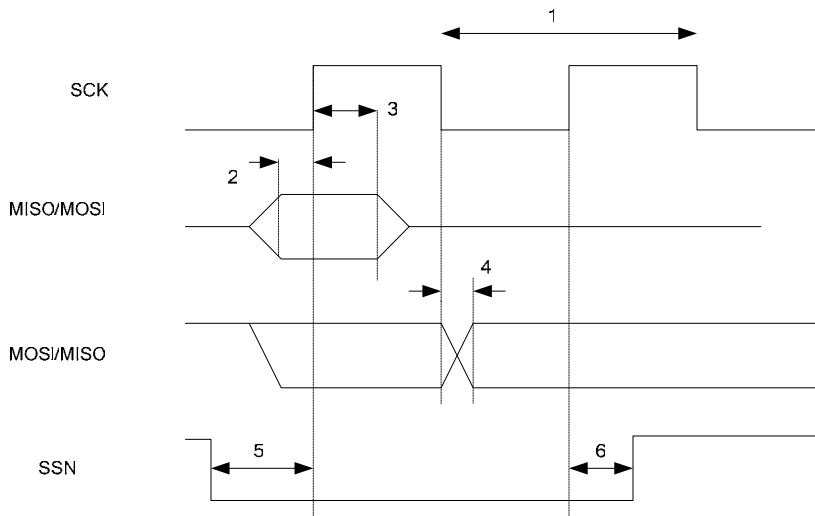

Figure 2: SPI AC Characteristics

7.13 Debug Interface AC Characteristics

T<sub>A</sub>=85°C, VDD=3.0V if nothing else stated. Measured on Chipcon's CC2510Fx EM reference design.

Parameter	Min	Typ	Max	Unit	Condition/Note
Debug clock period	31.25			ns	See item 1 Figure 3
Debug data setup	5				See item 2 Figure 3
Debug data hold	5				See item 3 Figure 3
Clock to data delay			10		See item 4 Figure 3, load = 10 pF
RESET_N inactive after P2_2 rising	10				See item 5 Figure 3

Table 19: Debug Interface AC Characteristics

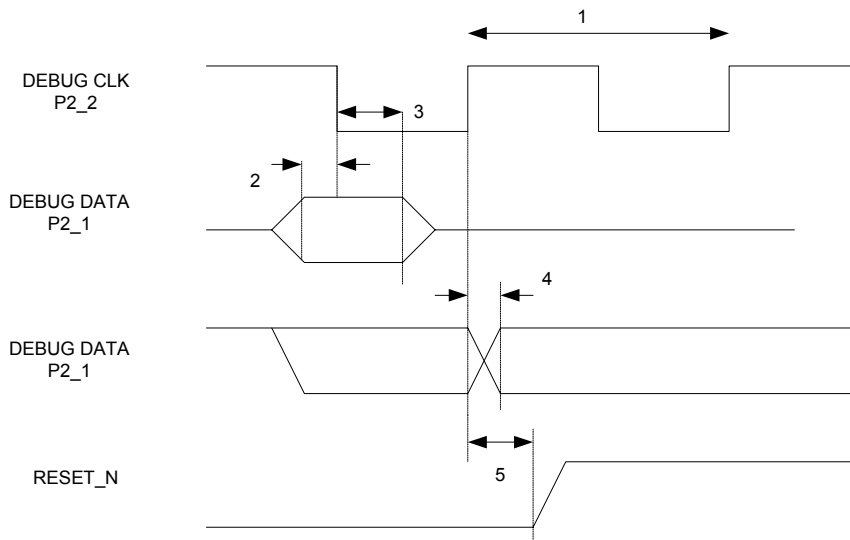

Figure 3: Debug Interface AC Characteristics

7.14 Port Outputs AC Characteristics

T<sub>A</sub>=85°C, VDD=3.0V if nothing else stated. Measured on Chipcon's CC2510Fx EM reference design.

Parameter	Min	Typ	Max	Unit	Condition/Note
P0, P1, P2Port output pins, rise and fall time		10			Load = 10 pF Timing is with respect to 10% VDD and 90% VDD levels.

Table 20: Port Outputs AC Characteristics

## 7.15 Timer Inputs AC Characteristics

T<sub>A</sub> =85°C, VDD=3.0V if nothing else stated. Measured on Chipcon's *CC2510Fx* EM reference design.

Parameter	Min	Typ	Max	Unit	Condition/Note
Input capture pulse width	t <sub>SYCLK</sub>				Synchronizers determine the shortest input pulse that can be recognized. The synchronizers operate from the current system clock rate

**Table 21: Timer Inputs AC Characteristics**

## 7.16 DC Characteristics

The DC Characteristics of *CC2510Fx/CC2511Fx* are listed in Table 22 below.

T<sub>A</sub>=25°C, VDD=3.0V if nothing else stated. Measured on Chipcon's *CC2510Fx* EM reference design.

Digital Inputs/Outputs	Min	Typ	Max	Unit	Condition
Logic "0" input voltage	0	0.7	0.9	V	
Logic "1" input voltage	VDD-0.25	VDD	VDD	V	
Logic "0" output voltage	0	0	0.25	V	For up to 4mA output current on all pins except P1_0 and P1_1 which are up to 20 mA
Logic "1" output voltage	VDD-0.25	VDD	VDD	V	For up to 4mA output current on all pins except P1_0 and P1_1 which are up to 20 mA
Logic "0" input current	N/A	-1	-1	μA	Input equals 0V
Logic "1" input current	N/A	1	1	μA	Input equals VDD
I/O pin pull-up and pull-down resistor	17	20	23	kΩ	

**Table 22: DC Characteristics**

## 8 Pin and I/O Port Configuration

The *CC2510Fx* pinout is shown in Figure 4 and Table 23. See section 13.1 for details on the configuration of digital I/O ports.

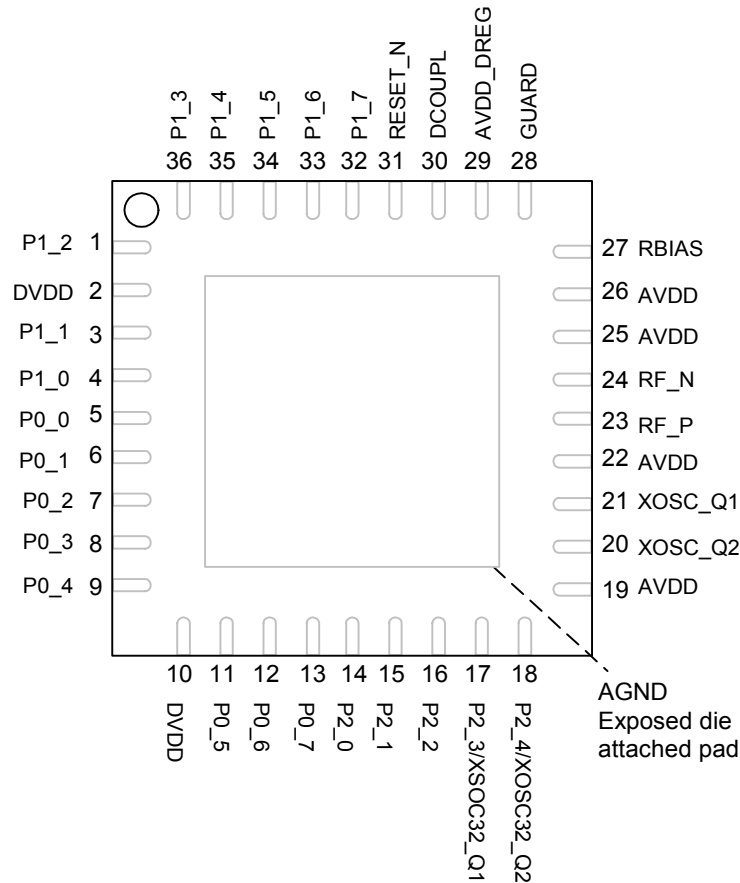

Figure 4: *CC2510Fx* Pinout top view

Note: The exposed die attach pad **must** be connected to a solid ground plane as this is the ground connection for the chip.

Pin	Pin name	Pin type	Description
-	GND	Ground	The exposed die attach pad must be connected to a solid ground plane
1	P1_2	D I/O	Port 1.2
2	DVDD	Power (Digital)	2.0V-3.6V digital power supply for digital I/O
3	P1_1	D I/O	Port 1.1
4	P1_0	D I/O	Port 1.0
5	P0_0	D I/O	Port 0.0
6	P0_1	D I/O	Port 0.1
7	P0_2	D I/O	Port 0.2
8	P0_3	D I/O	Port 0.3
9	P0_4	D I/O	Port 0.4
10	DVDD	Power (Digital)	2.0V-3.6V digital power supply for digital I/O
11	P0_5	D I/O	Port 0.5
12	P0_6	D I/O	Port 0.6
13	P0_7	D I/O	Port 0.7
14	P2_0	D I/O	Port 2.0
15	P2_1	D I/O	Port 2.1
16	P2_2	D I/O	Port 2.2
17	P2_3/XOSC32_Q1	D I/O	Port 2.3/32.768 kHz crystal oscillator pin 1
18	P2_4/XOSC32_Q2	D I/O	Port 2.4/32.768 kHz crystal oscillator pin 2
19	AVDD	Power (Analog)	2.0V-3.6V analog power supply connection
20	XOSC_Q2	Analog I/O	26 MHz crystal oscillator pin 2
21	XOSC_Q1	Analog I/O	26 MHz crystal oscillator pin 1, or external clock input
22	AVDD	Power (Analog)	2.0V-3.6V analog power supply connection
23	RF_P	RF I/O	Positive RF input signal to LNA in receive mode Positive RF output signal from PA in transmit mode
24	RF_N	RF I/O	Negative RF input signal to LNA in receive mode Negative RF output signal from PA in transmit mode
25	AVDD	Power (Analog)	2.0V-3.6V analog power supply connection
26	AVDD	Power (Analog)	2.0V-3.6V analog power supply connection
27	RBIAS	Analog I/O	External precision bias resistor for reference current
28	GUARD	Power (Digital)	Power supply connection for digital noise isolation
29	AVDD_DREG	Power (Digital)	2.0V-3.6V digital power supply for digital core voltage regulator
30	DCOUPPL	Power decoupling	1.8V digital power supply decoupling
31	RESET_N	DI	Reset, active low
32	P1_7	D I/O	Port 1.7
33	P1_6	D I/O	Port 1.6
34	P1_5	D I/O	Port 1.5
35	P1_4	D I/O	Port 1.4
36	P1_3	D I/O	Port 1.3

**Table 23: CC2510Fx Pinout overview**



The **CC2511Fx** pinout is shown in Figure 5 and Table 24. See section 13.1 for details on the configuration of digital I/O ports.

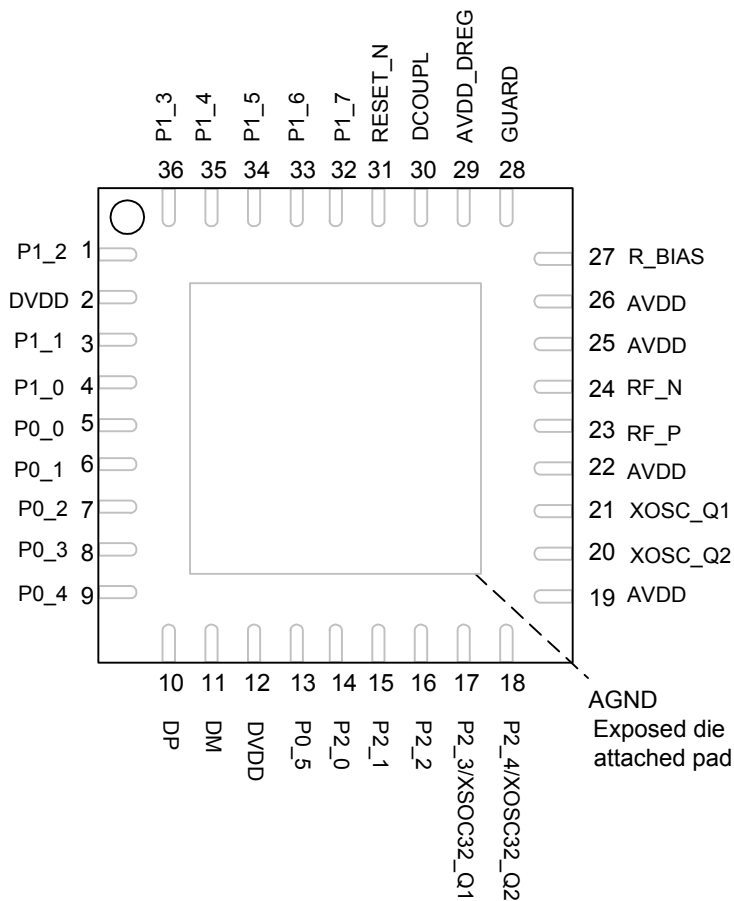

Figure 5: **CC2511Fx** Pinout top view

Note: The exposed die attach pad **must** be connected to a solid ground plane as this is the ground connection for the chip.

Pin	Pin name	Pin type	Description
-	GND	Ground	The exposed die attach pad must be connected to a solid ground plane
1	P1_2	D I/O	Port 1.2
2	DVDD	Power (Digital)	2.0V-3.6V digital power supply for digital I/O
3	P1_1	D I/O	Port 1.1
4	P1_0	D I/O	Port 1.0
5	P0_0	D I/O	Port 0.0
6	P0_1	D I/O	Port 0.1
7	P0_2	D I/O	Port 0.2
8	P0_3	D I/O	Port 0.3
9	P0_4	D I/O	Port 0.4
10	DP	USB I/O	USB Differential Data Bus Plus
11	DM	USB I/O	USB Differential Data Bus Minus
12	DVDD	Power (Digital)	2.0V-3.6V digital power supply for digital I/O
13	P0_5	D I/O	Port 0.5
14	P2_0	D I/O	Port 2.0
15	P2_1	D I/O	Port 2.1
16	P2_2	D I/O	Port 2.2
17	P2_3/XOSC32_Q1	D I/O	Port 2.3/32.768 kHz crystal oscillator pin 1
18	P2_4/XOSC32_Q2	D I/O	Port 2.4/32.768 kHz crystal oscillator pin 2
19	AVDD	Power (Analog)	2.0V-3.6V analog power supply connection
20	XOSC_Q2	Analog I/O	48 MHz crystal oscillator pin 2
21	XOSC_Q1	Analog I/O	48 MHz crystal oscillator pin 1, or external clock input
22	AVDD	Power (Analog)	2.0V-3.6V analog power supply connection
23	RF_P	RF I/O	Positive RF input signal to LNA in receive mode Positive RF output signal from PA in transmit mode
24	RF_N	RF I/O	Negative RF input signal to LNA in receive mode Negative RF output signal from PA in transmit mode
25	AVDD	Power (Analog)	2.0V-3.6V analog power supply connection
26	AVDD	Power (Analog)	2.0V-3.6V analog power supply connection
27	RBIAS	Analog I/O	External precision bias resistor for reference current
28	GUARD	Power (Digital)	Power supply connection for digital noise isolation
29	AVDD_DREG	Power (Digital)	2.0V-3.6V digital power supply for digital core voltage regulator
30	DCOUPPL	Power decoupling	1.8V digital power supply decoupling
31	RESET_N	DI	Reset, active low
32	P1_7	D I/O	Port 1.7
33	P1_6	D I/O	Port 1.6
34	P1_5	D I/O	Port 1.5
35	P1_4	D I/O	Port 1.4
36	P1_3	D I/O	Port 1.3

**Table 24: CC2511Fx Pinout overview**

9 Circuit Description

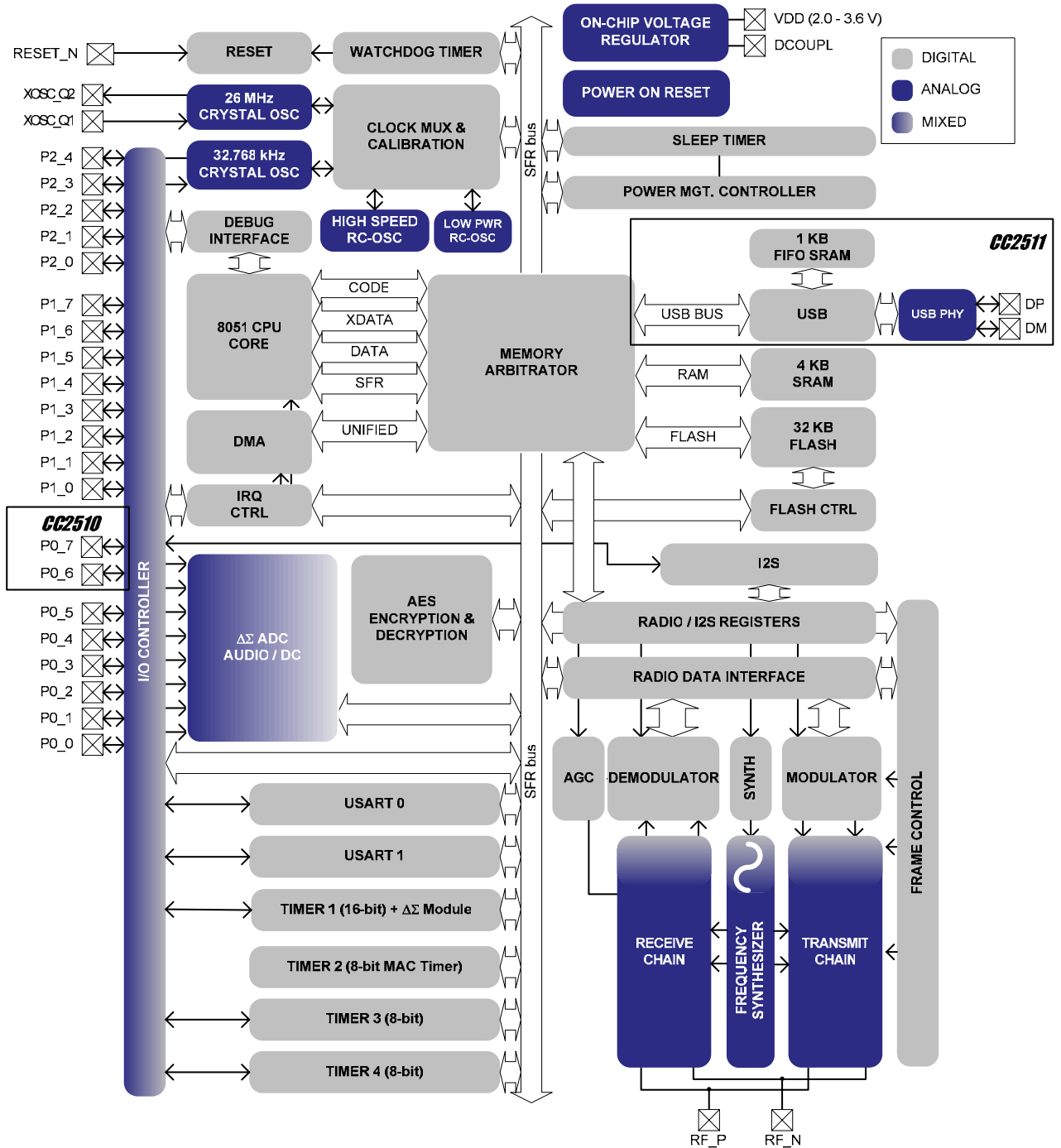

Figure 6: CC2510Fx/CC2511Fx Block Diagram

A block diagram of *CC2510Fx/CC2511Fx* is shown in Figure 6. The modules can be roughly divided into one out of three categories: CPU-related modules, radio-related modules and modules related to power, test and clock distribution. In the following subsections, a short description of each module that appears in Figure 6 is given.

## 9.1 CPU and Peripherals

The **8051 CPU core** is a single-cycle 8051-compatible core. It has three different memory access buses (SFR, DATA and CODE/XDATA), a debug interface and an 18-input extended interrupt unit. See section 12 for details.

The **memory crossbar/arbitrator** is at the heart of the system as it connects the CPU and DMA controller with the physical memories and all peripherals through the SFR bus. The memory arbitrator has four memory access points, which can access three physical memories: a 1/2/4 KB SRAM, 8/16/32 KB flash memory or SFR registers. The memory arbitrator is responsible for performing arbitration and sequencing between simultaneous memory accesses to the same physical memory.

The **SFR bus** is drawn conceptually in the block diagram as a common bus that connects all hardware peripherals to the memory arbitrator. The SFR bus also provides access to the radio registers in the radio register bank even though these are indeed mapped into XDATA memory space.

The **1/2/4 KB SRAM** maps to the DATA memory space and part of the XDATA/CODE memory spaces. The memory is an ultra-low-power SRAM that retains its contents even when the digital part is powered off (power modes 2 and 3).

The **8/16/32 KB flash block** provides in-circuit programmable non-volatile program memory for the device and maps into the CODE and XDATA memory spaces. Writing to the flash block is performed through a **flash controller** that allows page-wise (1024 byte) erasure and byte-wise reprogramming. See section 13.16 for details.

A versatile five-channel **DMA controller** is available in the system. It accesses memory using a unified memory space (XDATA) and has therefore access to all physical memories. Each channel is configured (trigger event,

priority, transfer mode, addressing mode, source and destination pointers, and transfer count) with DMA descriptors anywhere in memory. Many of the hardware peripherals rely on the DMA controller for efficient operation (AES core, flash controller, USARTs, Timers and ADC interface) by performing data transfers between a single SFR address and flash/SRAM. See section 13.2 for details.

The **interrupt controller** services 18 interrupt sources, divided into six *interrupt groups*, each of which is associated with one out of four interrupt priorities. An interrupt request is serviced even if the device is in a sleep mode (power modes 1-3) by bringing the *CC2510Fx/CC2511Fx* back to active mode (power mode 0).

The **debug interface** implements a proprietary two-wire serial interface that is used for in-circuit debugging. Through this debug interface it is possible to perform an erasure of the entire flash memory, control which oscillators are enabled, stop and start execution of the user program, execute supplied instructions on the 8051 core, set code breakpoints, and single step through instructions in the code. Using these techniques, it is possible to elegantly perform in-circuit debugging and external flash programming. See section 12.9 for details.

The **I/O-controller** is responsible for all general-purpose I/O pins. The CPU can configure whether peripheral modules control certain pins or whether they are under software control. It uses as I/O whether each pin is configured as an input or output, and if a pull-up or pull-down resistor in the pad is connected. Each peripheral that connects to the I/O-pins can choose between two different locations to ensure flexibility in various applications. See section 13.1 for details.

The **sleep timer** is an ultra-low power timer that counts 32.768 kHz crystal oscillator or 32 - 34.6667 kHz RC oscillator periods. The sleep timer runs continuously in all operating modes except power mode 3. It can be configured in one of several resolution modes, to strike the right balance between timer resolution and timeout period. Typical uses for it is as a real-time counter that runs regardless of operating mode (except power mode 3) or as a wakeup timer to get out of power modes 1 or 2. See section 13.5 for details.

A built-in **watchdog timer** allows the *CC2510Fx/CC2511Fx* to reset itself in case the

firmware hangs. When enabled, the watchdog timer must be cleared periodically, otherwise it will reset the device when it times out. See section 13.12 for details.

**Timer 1** is a 16-bit timer with timer/counter/PWM functionality. It has a programmable prescaler, a 16-bit period value and three individually programmable counter/capture channels each with a 16-bit compare value. Each of the counter/capture channels can be used as PWM outputs or to capture the timing of edges on input signals. A second order Sigma-Delta noise shaper mode is also supported for audio applications. See section 13.3 for details.

**Timer 2 (MAC timer)** is specially designed to support time-slotted protocols in software. The timer has a configurable timer period and 18-bit tunable prescaler range. See section 13.4 for details.

**Timers 3 and 4** are 8-bit timers with timer/counter/PWM functionality. They have a programmable prescaler, an 8-bit period value and one programmable counter/capture channel with an 8-bit compare value. Each of the counter/capture channels can be used as PWM outputs or to capture the timing of edges on input signals. See section **Error! Reference source not found.** for details.

**USART 0 and 1** are each configurable as either an SPI master/slave or a UART. They provide double buffering on both RX and TX to support high-throughput full-duplex applications. Each has its own high-precision baud-rate generator thus leaving the ordinary timers free for other uses. See section 13.13 for details.

The **AES encryption/decryption core** allows the user to encrypt and decrypt data using the AES algorithm with 128-bit keys. See section 13.9 for details.

The **ADC** supports 8 to 14 bits of resolution in a 30 kHz to 4 kHz bandwidth respectively. DC and audio conversion with up to eight input channels (Port 0) is possible. The inputs can be selected as single ended or differential. The reference voltage can be internal, AVDD,

or a single ended or differential external signal. The ADC also has a temperature sensor input channel. The ADC can automate the process of periodic sampling or conversion over a sequence of channels. See Section 13.7 for details.

The **USB** allows the **CC2511Fx** to implement a Full-Speed USB 2.0 compatible device. The USB has a dedicated 1 KB SRAM that is used for the endpoint FIFOs. 5 endpoints are available in addition to control endpoint 0. Each of these endpoints must be configured as Bulk/Interrupt or Isochronous and can be used as IN, OUT or IN/OUT. Double buffering of packets is also supported for endpoints 1-5. The maximum FIFO memory available for each endpoint is as follows: 32 bytes for endpoint 0, 32 bytes for endpoint 1, 64 bytes for endpoint 2, 128 bytes for endpoint 3, 256 bytes for endpoint 4 and 512 bytes for endpoint 5. When an endpoint is used as IN/OUT the FIFO memory available for the endpoint can be distributed between IN and OUT depending on the demands of the application. *The USB does not exist on the CC2510Fx.* See section 13.15 for details.

The **I2S** can be used to send/receive audio samples to/from an external sound processor or DAC and may operate at full or half duplex. Samples of up to 16-bits resolution can be used although the I2S can be configured to send more low order bits if necessary to be compliant with the resolution of the receiver. (up to 32 bit) The maximum bit-rate supported is 3.5 Mbps. The I2S can be configured as a master or slave device and supports both mono and stereo. Automatic  $\mu$ -Law expansion and compression can also be configured. See section 13.14 on page 158 for details.

## 9.2 Radio

**CC2510Fx/CC2511Fx** features an RF transceiver based on the industry-leading **CC2500**, requiring very few external components. See Section 15 for details.

## 10 Power Control

The *CC2510Fx/CC2511Fx* has four power modes, called PM0, PM1, PM2 and PM3. PM0 is the active mode while PM3 has the lowest power consumption. The power modes are shown in Table 25 together with voltage regulator and oscillator options.

Power Mode	High speed oscillator	Low-speed oscillator	Voltage regulator (digital)
Configuration	A None B 26/48 MHz XOSC C HS RCOSC	A None B Low power RCOSC C 32.768 kHz XOSC	
PM0	B, C	B, C	On
PM1	A	B, C	On
PM2	A	B, C	Off
PM3	A	A	Off

**Table 25: Power modes**

**PM0:** The full functional mode. The voltage regulator to the digital core is on and either the high speed RC oscillator or the 26/48 MHz crystal oscillator or both are running. Either the low power RC oscillator or the 32.768 kHz crystal oscillator is running.

**PM1:** The voltage regulator to the digital part is on. Neither the 26/48 MHz crystal oscillator nor the high speed RC oscillator is running. Either the low power RC oscillator or the 32.768 kHz crystal oscillator is running. The system will go to PM0 on reset or an external interrupt or when the sleep timer expires.

**PM2:** The voltage regulator to the digital core is turned off. Neither the 26/48 MHz crystal oscillator nor the high speed RC oscillator is running. Either the low power RC oscillator or the 32.768 kHz crystal oscillator is running. The system will go to PM0 on reset or an external interrupt or when the sleep timer expires. The *CC2511Fx* will lose all USB state information when PM2 is entered. *Thus, PM2 should not be used with USB.*

**PM3:** The voltage regulator to the digital core is turned off. None of the oscillators are running. The system will go to PM0 on reset or an external interrupt. The *CC2511Fx* will lose all USB state information when PM3 is entered. *Thus, PM3 should not be used with USB.*

## 11 Application Circuit

This section describes the recommended application circuit for the RF part of the *CC2510Fx/CC2511Fx*, together with crystal oscillator connections and USB.

Only a few external components are required for using the *CC2510Fx/CC2511Fx* RF transceiver. The recommended application circuit for *CC2510Fx* is shown in Figure 7. The recommended application circuits for *CC2511Fx* are shown in Figure 8 and Figure 9. The first circuit uses a fundamental crystal and the second uses a 3<sup>rd</sup> overtone crystal. The external components are described in Table 26, and typical values are given in Table 27. Notice that all application circuits are shown excluding supply decoupling capacitors and digital I/O.

### 11.1 Bias resistor

The bias resistor R271 is used to set an accurate bias current. It is very important to use the specified tolerance for this resistor.

### 11.2 Balun and RF matching

C232, C242, L231 and L241 form the recommended balun that converts the differential RF port on *CC2510Fx/CC2511Fx* to a single-ended RF signal. (C241 and C231 are also needed for DC blocking). Together with an appropriate LC network, the balun components also transform the impedance to match a 50  $\Omega$  antenna (or cable). Component values for the RF balun and LC network are easily found using the SmartRF<sup>®</sup> Studio software. Suggested values are listed in Table 27. The balun and LC filter component values and their placement are important to keep the performance optimized. It is recommended to follow the CC2510EM / CC2511Dongle reference design.

### 11.3 Crystal

The crystal oscillator for the *CC2510Fx* uses an external crystal X1, with two loading capacitors (C201 and C211). See section 14 on page 190 for details.

The *CC2511Fx* should use a 48 MHz fundamental (X3) or a 48 MHz 3<sup>rd</sup> overtone low cost external crystal (X4). Depending on the option selected, different loading capacitors (C203, C214) or (C202, C212, C213) must be used. When X4 is used, an inductor, L281, must also be connected in series with C212.

The circuit also shows the connections for the optional 32.768 kHz crystal oscillator, with external crystal X2 and loading capacitors C181 and C171. This crystal oscillator is used by the Sleep Timer providing a real-time clock function and is not required for radio operation. The sleep timer may use the internal RC oscillator as an alternative to X2. The internal RC oscillator is less accurate but saves cost and board space. When not using X2 P2\_3 and P2\_4 may be used as general IO pins.

### 11.4 USB (*CC2511Fx*)

For the *CC2511Fx* the DP and DM pins need series resistors R262 and R263 for impedance matching and the DP line must have a pull-up resistor, R264. The series resistors should match the 90  $\Omega$  +/- 5% characteristic impedance of the USB bus.

Notice that the pull-up resistor must be tied to a voltage source between 3.0 and 3.6 V (typically 3.3V). The voltage source must be derived from or controlled by the  $V_{BUS}$  power supply, provided by the USB cable, such that when  $V_{BUS}$  is removed, the pull-up resistor does not provide current to the D+ line. The pull-up resistor may be connected directly between  $V_{BUS}$  and the D+ line. Or if the *CC2511Fx* firmware need the ability to disconnect from the USB bus, a I/O pin on the *CC2511Fx* can be used to control the pull-up resistor.

### 11.5 Power supply decoupling

The power supply must be properly decoupled close to the supply pins. Note that decoupling capacitors are not shown in the application circuit. The placement and the size of the decoupling capacitors are very important to achieve the optimum performance. Chipcon provides a reference design that should be followed closely.

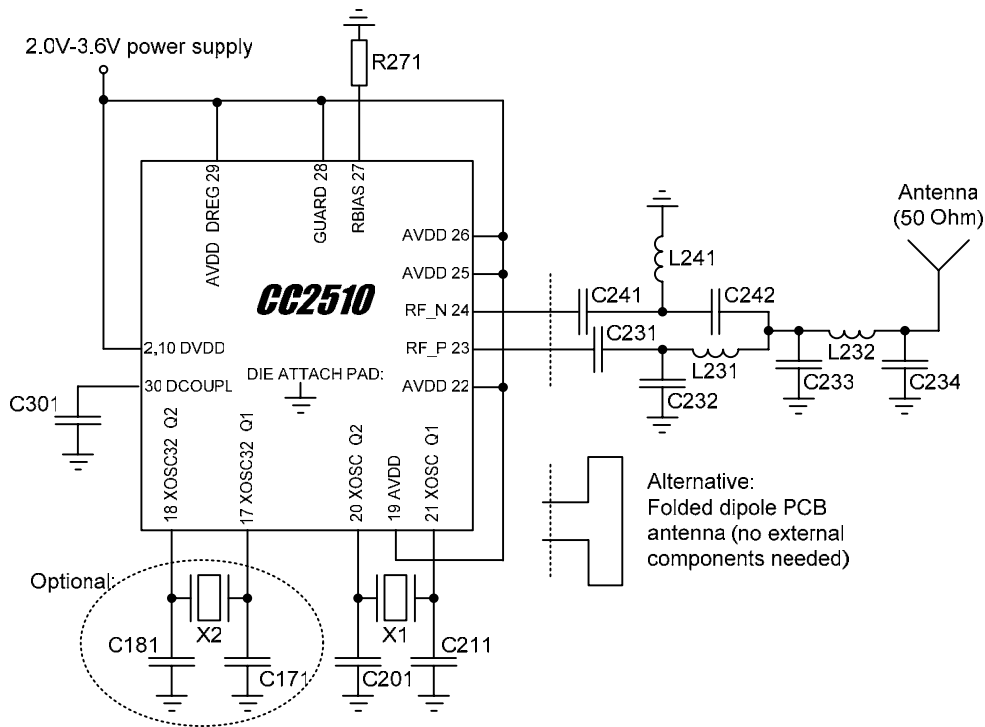

Figure 7: Application Circuit for *CC2510Fx*

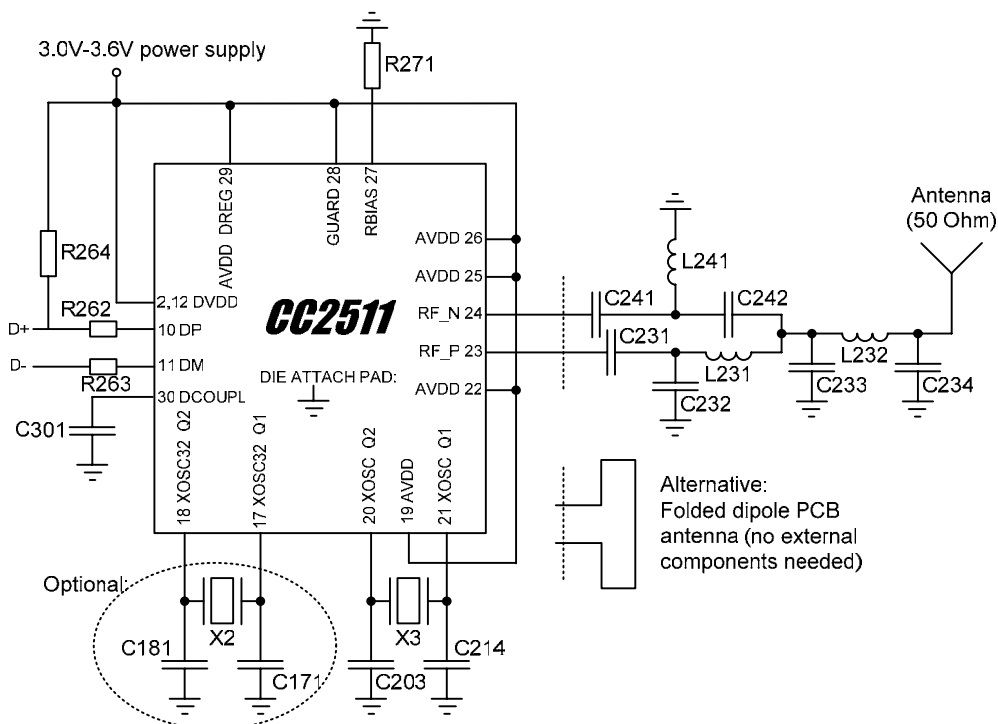

Figure 8: Application Circuit for *CC2511Fx* with USB and fundamental crystal



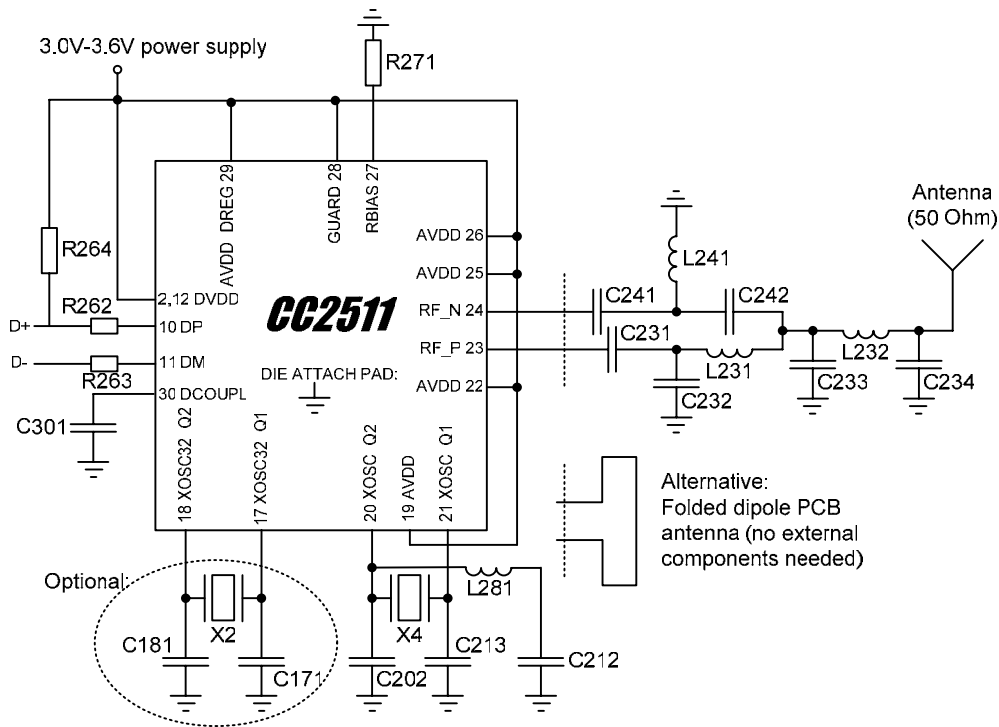

Figure 9: Application Circuit for **CC2511Fx** with USB and 3<sup>rd</sup> overtone crystal

Component	Description
C301	Decoupling capacitor for on-chip voltage regulator to digital part
C203/C214	Crystal loading capacitors (fundamental crystal)
C202/C212/C213	Crystal loading capacitors (3 <sup>rd</sup> overtone crystal)
C201/C211	Crystal loading capacitors, see section 14 on page 190 for details
C231/C241	RF balun DC blocking capacitors
C232/C241	RF balun/matching capacitors
C233/C234	RF LC filter/matching capacitors
C181/C171	Crystal loading capacitors if X2 is used.
L231/L241	RF balun/matching inductors (inexpensive multi-layer type)
L232	RF LC filter inductor (inexpensive multi-layer type)
L281	Crystal inductor
R271	56 kΩ resistor for internal bias current reference, 1% tolerance
R264	D+ Pullup resistor
R262/R263	D+ / D- series resistors for impedance matching
X1	26 MHz -27 MHz crystal, see section 14 on page 190 for details
X2	32.768 kHz crystal, optional
X3	48 MHz crystal (fundamental)
X4	48 MHz crystal (3 <sup>rd</sup> overtone)

Table 26: Overview of external components (excluding supply decoupling capacitors)

Component	Value
C301	100 nF±10%, 0402 X5R
C203/C214	33 pF
C202	56 pF
C212	10 nF
C213	33 pF
C201, C211	27 pF±5%, 0402 NP0
C231, C241	100 pF±5%, 0402 NP0
C171, C181	15 pF±5%, 0402 NP0
C232, C242	1.0 pF±0.25 pF, 0402 NP0
C233	1.8 pF±0.25 pF, 0402 NP0
C234	1.5 pF±0.25 pF, 0402 NP0
L231, L232, L241	1.2 nH±0.3 nH, 0402 monolithic, Murata LQG-15 series
L281	470 nH±10%, Murata LQM18NNR47K00
R271	56 kΩ±1%, 0402
R264	1.5 kΩ±5%
R262/R263	
X1	26.0 MHz surface mount crystal
X2	32.768 kHz surface mount crystal (optional)
X3	48.0 MHz surface mount crystal (fundamental)
X4	48.0 MHz surface mount crystal (3 <sup>rd</sup> overtone)

**Table 27: Bill Of Materials for the CC2510Fx/CC2511Fx application circuits (subject to changes)**

## 12 8051 CPU

This section describes the 8051 CPU core, with interrupts, memory and instruction set.

### 12.1 8051 CPU Introduction

The *CC2510Fx/CC2511Fx* includes an 8-bit CPU core, which is an enhanced version of the industry standard 8051 core.

The enhanced 8051 core uses the standard 8051 instruction set. Instructions execute faster than the standard 8051 due to the following:

- One clock per instruction cycle is used as opposed to 12 clocks per instruction cycle in the standard 8051.
- Redundant bus states are eliminated.
- Parallel execution of fetch and execute phases.

Since an instruction cycle is aligned with memory fetch when possible, most of the single byte instructions are performed in a single clock cycle. In addition to the speed improvement, the enhanced 8051 core also includes architectural enhancements:

- Dual data pointers
- Extended 18-source interrupt unit

The 8051 core is object code compatible with the industry standard 8051 microcontroller. That is, object code compiled with an industry standard 8051 compiler or assembler executes on the 8051 core and is functionally

### 12.3 Memory

The 8051 CPU has four different memory spaces:

**CODE.** A 16-bit read-only memory space for program memory.

**DATA.** An 8-bit read/write data memory space, which can be directly or indirectly accessed by a single CPU instruction. The lower 128 bytes of the DATA memory space can be addressed either directly or indirectly, the upper 128 bytes only indirectly.

**XDATA.** A 16-bit read/write data memory space access to which usually requires 4-5 CPU instruction cycles. Access to XDATA memory is also slower in hardware than DATA access as the CODE and XDATA memory spaces share a common bus on the CPU core

equivalent. However, because the 8051 core uses a different instruction timing than many other 8051 variants, existing code with timing loops may require modification. Also, because the peripheral units such as timers and serial ports differ from those on other 8051 cores, code which includes instructions using the peripheral units SFRs will not work correctly.

### 12.2 Reset

The *CC2510Fx/CC2511Fx* has three reset sources. The following events generate a reset:

- Forcing RESET\_N input pin low
- A power-on reset condition
- Watchdog timer reset condition

The initial conditions after a reset are as follows:

- I/O pins are configured as inputs with pull-up, except P1\_0 and P1\_1.
- CPU program counter is loaded with 0x0000 and program execution starts at this address
- All peripheral registers are initialized to their reset values (refer to register descriptions)
- Watchdog timer is disabled

and instruction pre-fetch from CODE can thus not be performed in parallel with XDATA accesses.

**SFR.** A 7-bit read/write register memory space, which can be directly accessed by a single CPU instruction. For SFR registers whose address is divisible by eight, each bit is also individually addressable.

The four different memory spaces are distinct in the 8051 architecture, but are partly overlapping in the *CC2510Fx/CC2511Fx* to ease DMA transfers and hardware debugger operation.

How the different memory spaces are mapped onto the three physical memories (8/16/32 KB flash program memory, 1/2/4 KB SRAM and

hardware registers) is described in section

12.3.2.

12.3.1 Memory Map

This section gives an overview of the memory map.

The memory differs from the standard 8051 memory map in two important aspects, as described below.

First, all the physical memories CODE, DATA, XDATA, radio register, USB registers and most of the hardware SFR registers are mapped into a unified XDATA memory space as shown in Figure 10. Note that 128 upper bytes of DATA are located at a different XDATA location than the SFR registers and they can be accessed directly.

Mapping all the memory spaces to XDATA is primarily done to allow the DMA controller access them, thus allowing DMA transfers between these areas. This also means that

any MCU operation that read/write or manipulate a XDATA variable can be used on the entire unified XDATA memory space, except writing to or changing data in the 8/16/32 KB CODE memory space (FLASH).

The hardware SFR register shown in gray in Table 29 are not mapped into the XDATA memory space, thus they can not be accessed from the DMA.

Secondly, the CODE memory space is mapped identically to the XDATA. See Figure 10.

This is primarily to done to allow program execution out of the SRAM/XDATA.

Details about the mapping of all 8051 memory spaces are given in the next section.

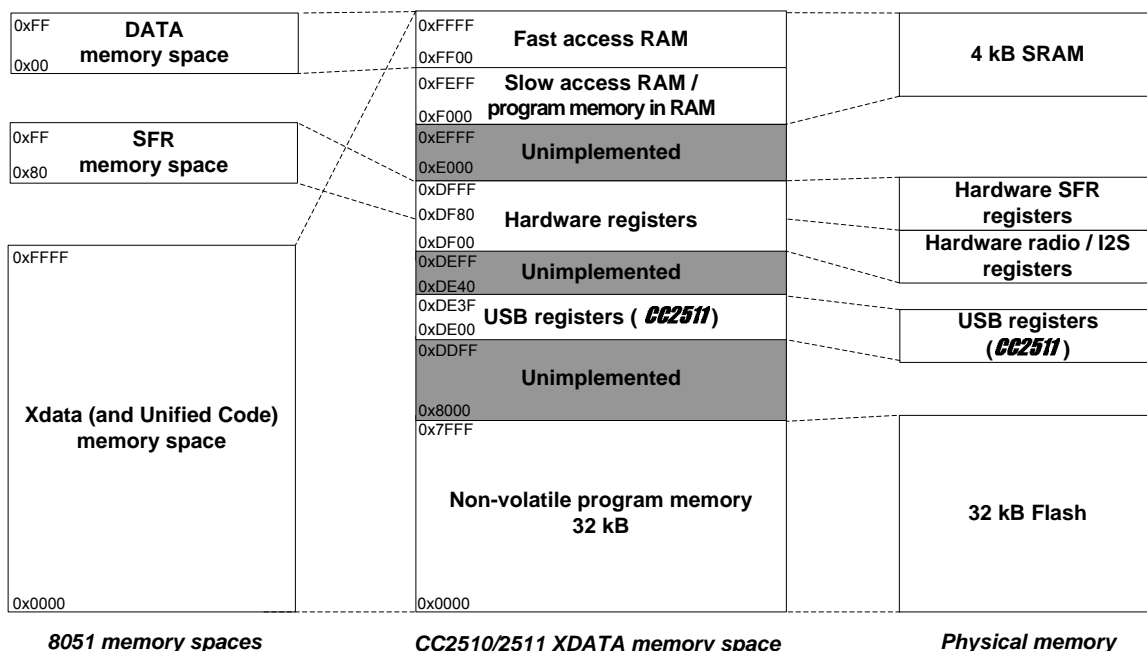

Figure 10: CC2510Fx/CC2511Fx XDATA memory space (CC2510F32/CC2511F32 shown here)

12.3.2 Memory Space

This section describes the details of each CPU memory space. The caption of each chapter refer to the memory spaces in a standard 8051, any differences between the standard 8051 and CC2510Fx/CC2511Fx is described.

XDATA memory space.

On a standard 8051 this memory space would hold any extra RAM available (in addition to the 128/256 byte DATA)

The **CC2510Fx/CC2511Fx** has a total of 1, 2 or 4 KB SRAM, starting at address 0xF000. Compilers/assemblers must take into consideration that the first address of usable SRAM starts at address 0xF000 instead of 0x0000.

The 256 bytes from 0xFF00 to 0xFFFF are the DATA memory mapped to XDATA. These bytes are also reached through the DATA memory space.

The 350 bytes of XDATA in location 0xFDA2-0xFEFF on CC2510F32 and CC2511F32 do

not retain data when power modes PM2/3 are entered. However these bytes may be used in PM0 and PM1 on the F32 versions.

The rest of the SRAM will retain its contents in PM0 to 3. Refer to section 13.10 on page 140 for a detailed description of power modes.

See Table 28 for an overview of the SRAM and Flash memory map.

	DATA RAM	No Retention RAM	XDATA RAM	Flash Memory
CC251xF8	0xFF00 – 0xFFFF	–	0xF000 – 0xF2FF	0x0000 – 0x1FFF
CC251xF16	0xFF00 – 0xFFFF	–	0xF000 – 0xF6FF	0x0000 – 0x3FFF
CC251xF32	0xFF00 – 0xFFFF	0xFDA2 – 0xFEFF	0xF000 – 0xFDA9	0x0000 – 0x7FFF

**Table 28 SRAM and Flash Memory Map**

In addition the following is mapped into the XDATA memory space:

- The 8, 16 and 32 KB flash program memory (CODE) is mapped into the address ranges 0x0000-0x1FFF, 0x0000-0x3FFF and 0x0000-0x7FFF respectively.
- Radio registers are mapped into address range 0xDF00-0xDF3D.
- I2S registers are mapped into the address range 0xDF40-0xDF48.
- All SFR except the registers shown in gray in Table 29. are mapped into address range 0xDF80-0xDFFF.
- The USB registers are mapped into the address range 0xDE00-0xDE3F on the **CC2511Fx**, but are not implemented on the **CC2510Fx**.

This memory mapping allows the DMA controller (and the CPU) access to all the physical memories in a single unified address space.

## CODE memory space.

On a standard 8051 this memory space would hold the program memory, where the MCU reads the program/instructions.

The **CC2510Fx/CC2511Fx** has 8, 16 or 32 KB flash program memory intended to hold the MCU program. The Flash is mapped into CODE and starts at address 0x0000.

In addition all other memory spaces are mapped into the CODE memory space. The mapping is identical to XDATA (see the XDATA memory space)

Thus the **CC2510Fx/CC2511Fx** MCU may execute a program stored in SRAM. This allows the program to be easily updated without writing to flash (which have a limited erase/write cycles) This is particularly useful on the **CC2511Fx**, where parts of the firmware can be downloaded from the windows USB driver.

Executing a program from SRAM instead of FLASH will also result in a lower power consumption and may be interesting for battery powered devices.

## DATA memory space.

The DATA memory space of **CC2510Fx/CC2511Fx** is identical to a standard 8051, with 256 byte of RAM accessible through the 8-bit address range of DATA

memory. Just like a standard 8051 the upper 128 byte share address with the SFR and can only be accessed indirectly, the stack is normally located here. The lower 48 bytes are reserved, and hold 4 register banks used by the MCU. The 16 bytes on addresses 0x20 to 0x2F are bit addressable.

The DATA memory will retain its contents in PM0 to 3

The DATA memory can be accessed through the XDATA and CODE memory spaces at the address ranges 0xFF00-0xFFFF.

### SFR memory space.

The SFR memory space is identical to a standard 8051.

The 128-entry hardware register area is accessed through this memory space.

Unlike a standard 8051, the SFR registers are also accessible through the XDATA and CODE address space at the address range 0xDF80-0xDFFF. Some CPU-specific SFR registers reside inside the CPU core and can only be accessed using the SFR memory

space and not through the duplicate mapping into XDATA/CODE memory space, these registers are shown in gray in Table 29.

### 12.3.3 Data Pointers

The *CC2510Fx/CC2511Fx* has two data pointers, DPTR0 and DPTR1 to accelerate the movement of data blocks to/from memory. The data pointers are generally used to access CODE or XDATA space e.g.

```
MOVC A, @A+DPTR
```

```
MOV A, @DPTR.
```

The data pointer select bit, bit 0 in the Data Pointer Select register *DPS*, chooses which data pointer shall be the active one during execution of an instruction that uses the data pointer, e.g. in one of the above instructions.

The data pointers are two bytes wide consisting of the following SFRs:

- DPTR0 – DPH0 : DPL0
- DPTR1 – DPH1 : DPL1

### DPH0 (0x83) – Data Pointer 0 High Byte

Bit	Name	Reset	R/W	Description
7:0	DPH0[7:0]	0	R/W	Data pointer 0, high byte

### DPL0 (0x82) – Data Pointer 0 Low Byte

Bit	Name	Reset	R/W	Description
7:0	DPL0[7:0]	0	R/W	Data pointer 0, low byte

### DPH1 (0x85) – Data Pointer 1 High Byte

Bit	Name	Reset	R/W	Description
7:0	DPH1[7:0]	0	R/W	Data pointer 1, high byte

### DPL1 (0x84) – Data Pointer 1 Low Byte

Bit	Name	Reset	R/W	Description
7:0	DPL1[7:0]	0	R/W	Data pointer 1, low byte

### DPS (0x92) – Data Pointer Select

Bit	Name	Reset	R/W	Description
7:1	–	0x00	R0	Not used

Bit	Name	Reset	R/W	Description
0	DPS	0	R/W	Data pointer select. Selects active data pointer. 0 DPTR0 1 DPTR1

### 12.3.4 XDATA Memory Access

The **CC2510Fx/CC2511Fx** provides an additional SFR register **MPAGE**. This register is used during instructions **MOVX A,@Ri** and **MOVX @Ri,A**. **MPAGE** gives the 8 most significant address bits, while the register **Ri** gives the 8 least significant bits.

In some 8051 implementations, this type of XDATA access is performed using **P2** to give the most significant address bits. Existing software may therefore have to be adapted to make use of **MPAGE** instead of **P2**.

### MPAGE (0x93)– Memory Page Select

Bit	Name	Reset	R/W	Description
7:0	MPAGE[7:0]	0x00	R/W	Memory page, high-order bits of address in <b>MOVX</b> instruction

## 12.4 SFR Registers

The Special Function Registers (SFRs) control several of the features of the 8051 CPU core and/or peripherals. Many of the 8051 core SFRs are identical to the standard 8051 SFRs. However, there are additional SFRs that control features that are not available in the standard 8051. The additional SFRs are used to interface with the peripheral units and RF transceiver.

Table 29 shows the address to all SFRs in **CC2510Fx/CC2511Fx**. The 8051 internal SFRs are shown with grey background, while the other SFRs are specific to **CC2510Fx/CC2511Fx**.

*Note: all internal SFRs (shown with grey background in Table 29), can only be accessed through SFR space as these registers are not mapped into XDATA space.*

Table 30 lists the additional SFRs that are not standard 8051 peripheral SFRs or CPU-internal SFRs. The additional SFRs are described in the relevant sections for each peripheral function.

8 bytes									
80	P0	SP	DPL0	DPH0	DPL1	DPH1	U0CSR	PCON	87
88	TCON	P0IFG	P1IFG	P2IFG	PICTL	P1IEN	-	P0INP	8F
90	P1	RFIM	DPS	MPAGE	-	ENDIAN	-	-	97
98	S0CON	-	IEN2	S1CON	T2CT	T2PR	T2CTL	-	9F
A0	P2	WORIRQ	WORCTL	WOREVT0	WOREVT1	WORTIME0	WORTIME1	-	A7
A8	IEN0	IP0	-	FWT	FADDRL	FADDRH	FCTL	FWDATA	AF
B0	-	ENCDI	ENCDO	ENCCS	ADCCON1	ADCCON2	ADCCON3	-	B7
B8	IEN1	IP1	ADCL	ADCH	RNDL	RNDH	SLEEP	-	BF
C0	IRCON	U0DBUF	U0BAUD	-	U0UCR	U0GCR	CLKCON	MEMCTR	C7
C8	-	WDCTL	T3CNT	T3CTL	T3CCTL0	T3CC0	T3CCTL1	T3CC1	CF
D0	PSW	DMAIRQ	DMA1CFGL	DMA1CFGH	DMA0CFGL	DMA0CFGH	DMAARM	DMAREQ	D7
D8	TIMIF	RFD	T1CC0L	T1CC0H	T1CC1L	T1CC1H	T1CC2L	T1CC2H	DF
E0	ACC	RFST	T1CNTL	T1CNTH	T1CTL	T1CCTL0	T1CCTL1	T1CCTL2	E7
E8	IRCON2	RFIF	T4CNT	T4CTL	T4CCTL0	T4CC0	T4CCTL1	T4CC1	EF
F0	B	PERCFG	ADCCFG	P0SEL	P1SEL	P2SEL	P1INP	P2INP	F7
F8	U1CSR	U1DBUF	U1BAUD	U1UCR	U1GCR	P0DIR	P1DIR	P2DIR	FF

Table 29: SFR address overview

Table 30: CC2510Fx/CC2511Fx specific SFR overview

Register name	SFR Address	Module	Description
ADCCON1	0xB4	ADC	ADC Control 1
ADCCON2	0xB5	ADC	ADC Control 2
ADCCON3	0xB6	ADC	ADC Control 3
ADCL	0xBA	ADC	ADC Data Low
ADCH	0xBB	ADC	ADC Data High
RNDL	0xBC	ADC	Random Number Generator Data Low
RNDH	0xBD	ADC	Random Number Generator Data High
ENCDI	0xB1	AES	Encryption/Decryption Input Data
ENCDO	0xB2	AES	Encryption/Decryption Output Data
ENCCS	0xB3	AES	Encryption/Decryption Control and Status
DMAIRQ	0xD1	DMA	DMA Interrupt Flag
DMA1CFGL	0xD2	DMA	DMA Channel 1-4 Configuration Address Low
DMA1CFGH	0xD3	DMA	DMA Channel 1-4 Configuration Address High
DMA0CFGL	0xD4	DMA	DMA Channel 0 Configuration Address Low
DMA0CFGH	0xD5	DMA	DMA Channel 0 Configuration Address High
DMAARM	0xD6	DMA	DMA Channel Arm
DMAREQ	0xD7	DMA	DMA Channel Start Request and Status
FWT	0xAB	FLASH	Flash Write Timing
FADDRL	0xAC	FLASH	Flash Address Low
FADDRH	0xAD	FLASH	Flash Address High



Register name	SFR Address	Module	Description
FCTL	0xAE	FLASH	Flash Control
FWDATA	0xAF	FLASH	Flash Write Data
P0IFG	0x89	IOC	Port 0 Interrupt Status Flag
P1IFG	0x8A	IOC	Port 1 Interrupt Status Flag
P2IFG	0x8B	IOC	Port 2 Interrupt Status Flag
PICTL	0x8C	IOC	Port Pins Interrupt Mask and Edge
P1IEN	0x8D	IOC	Port 1 Interrupt Mask
P0INP	0x8F	IOC	Port 0 Input Mode
PERCFG	0xF1	IOC	Peripheral I/O Control
ADCCFG	0xF2	IOC	ADC Input Configuration
P0SEL	0xF3	IOC	Port 0 Function Select
P1SEL	0xF4	IOC	Port 1 Function Select
P2SEL	0xF5	IOC	Port 2 Function Select
P1INP	0xF6	IOC	Port 1 Input Mode
P2INP	0xF7	IOC	Port 2 Input Mode
P0DIR	0xFD	IOC	Port 0 Direction
P1DIR	0xFE	IOC	Port 1 Direction
P2DIR	0xFF	IOC	Port 2 Direction
MEMCTR	0xC7	MEMORY	Memory System Control
SLEEP	0xBE	PMC	Sleep Mode Control
CLKCON	0xC6	PMC	Clock Control
RFIM	0x91	RF	RF Interrupt Mask
RFD	0xD9	RF	RF Data
RFIF	0xE9	RF	RF Interrupt flags
RFST	0xE1	RF	RF Strobe Commands
WORIRQ	0xA1	Sleep Timer	Sleep Timer Interrupts
WORCTRL	0xA2	Sleep Timer	Sleep Timer Control
WOREVT0	0xA3	Sleep Timer	Sleep Timer Event 0 Timeout Low Byte
WOREVT1	0xA5	Sleep Timer	Sleep Timer Event 0 Timeout High Byte
WORTIME0	0xA4	Sleep Timer	Sleep Timer Low Byte
WORTIME1	0xA6	Sleep Timer	Sleep Timer High Byte
T1CC0L	0xDA	Timer1	Timer 1 Channel 0 Capture/Compare Value Low
T1CC0H	0xDB	Timer1	Timer 1 Channel 0 Capture/Compare Value High
T1CC1L	0xDC	Timer1	Timer 1 Channel 1 Capture/Compare Value Low
T1CC1H	0xDD	Timer1	Timer 1 Channel 1 Capture/Compare Value High
T1CC2L	0xDE	Timer1	Timer 1 Channel 2 Capture/Compare Value Low
T1CC2H	0xDF	Timer1	Timer 1 Channel 2 Capture/Compare Value High
T1CNTL	0xE2	Timer1	Timer 1 Counter Low
T1CNTH	0xE3	Timer1	Timer 1 Counter High
T1CTL	0xE4	Timer1	Timer 1 Control and Status
T1CCTL0	0xE5	Timer1	Timer 1 Channel 0 Capture/Compare Control

Register name	SFR Address	Module	Description
T1CCTL1	0xE6	Timer1	Timer 1 Channel 1 Capture/Compare Control
T1CCTL2	0xE7	Timer1	Timer 1 Channel 2 Capture/Compare Control
T2CT	0x9C	Timer2	Timer 2 Timer Count
T2PR	0x9D	Timer2	Timer 2 Prescaler
T2CTL	0x9E	Timer2	Timer 2 Control
T3CNT	0xCA	Timer3	Timer 3 Counter
T3CTL	0xCB	Timer3	Timer 3 Control
T3CCTL0	0xCC	Timer3	Timer 3 Channel 0 Capture/Compare Control
T3CC0	0xCD	Timer3	Timer 3 Channel 0 Capture/Compare Value
T3CCTL1	0xCE	Timer3	Timer 3 Channel 1 Capture/Compare Control
T3CC1	0xCF	Timer3	Timer 3 Channel 1 Capture/Compare Value
T4CNT	0xEA	Timer4	Timer 4 Counter
T4CTL	0xEB	Timer4	Timer 4 Control
T4CCTL0	0xEC	Timer4	Timer 4 Channel 0 Capture/Compare Control
T4CC0	0xED	Timer4	Timer 4 Channel 0 Capture/Compare Value
T4CCTL1	0xEE	Timer4	Timer 4 Channel 1 Capture/Compare Control
T4CC1	0xEF	Timer4	Timer 4 Channel 1 Capture/Compare Value
TIMIF	0xD8	TMINT	Timers 1/3/4 Joint Interrupt Mask/Flags
U0CSR	0x86	USART0	USART 0 Control and Status
U0DBUF	0xC1	USART0	USART 0 Receive/Transmit Data Buffer
U0BAUD	0xC2	USART0	USART 0 Baud Rate Control
U0UCR	0xC4	USART0	USART 0 UART Control
U0GCR	0xC5	USART0	USART 0 Generic Control
U1CSR	0xF8	USART1	USART 1 Control and Status
U1DBUF	0xF9	USART1	USART 1 Receive/Transmit Data Buffer
U1BAUD	0xFA	USART1	USART 1 Baud Rate Control
U1UCR	0xFB	USART1	USART 1 UART Control
U1GCR	0xFC	USART1	USART 1 Generic Control
ENDIAN	0x95	MEMORY	USB Endianess Control ( <i>CC2511Fx</i> )
WDCTL	0xC9	WDT	Watchdog Timer Control

## 12.5 CPU Registers

This section describes the internal registers used by the CPU.

### 12.5.1 Registers R0-R7

The *CC2510Fx/CC2511Fx* provides four register banks of eight registers each. These register banks are mapped in the DATA memory space

### 12.5.2 Program Status Word

at addresses 0x00-0x07, 0x08-0x0F, 0x10-0x17 and 0x18-0x1F. Each register bank contains the eight 8-bit register R0-R7. The register bank to be used is selected through the Program Status Word `PSW.RS[1:0]`.

The Program Status Word (PSW) contains several bits that show the current state of the CPU. The Program Status Word is accessible as an SFR and it is bit-addressable. PSW contains the Carry flag, Auxiliary Carry flag for

BCD operations, Register Select bits, Overflow flag and Parity flag. Two bits in PSW are uncommitted and can be used as user-defined status flags

### PSW (0xD0) – Program Status Word

Bit	Name	Reset	R/W	Description
7	CY	0	R/W	Carry flag. Set to 1 when the last arithmetic operation resulted in a carry (during addition) or borrow (during subtraction), otherwise cleared to 0 by all arithmetic operations.
6	AC	0	R/W	Auxiliary carry flag for BCD operations. Set to 1 when the last arithmetic operation resulted in a carry into (during addition) or borrow from (during subtraction) the high order nibble, otherwise cleared to 0 by all arithmetic operations.
5	F0	0	R/W	User-defined, bit-addressable
4:3	RS[1:0]	00	R/W	Register bank select bits. Selects which set of R7-R0 registers to use from four possible register banks in DATA space. 00 Bank 0, 0x00 – 0x07 01 Bank 1, 0x08 – 0x0F 10 Bank 2, 0x10 – 0x17 11 Bank 3, 0x18 – 0x1F
2	OV	0	R/W	Overflow flag, set by arithmetic operations. Set to 1 when the last arithmetic operation resulted in a carry (addition), borrow (subtraction), or overflow (multiply or divide). Otherwise, the bit is cleared to 0 by all arithmetic operations.
1	F1	0	R/W	User-defined, bit-addressable
0	P	0	R/W	Parity flag, parity of accumulator set by hardware to 1 if it contains an odd number of 1's, otherwise it is cleared to 0

#### 12.5.3 Accumulator

ACC is the accumulator. This is the source and destination of most arithmetic instructions, data transfer and other instructions. The

mnemonic for the accumulator (in instructions involving the accumulator) refers to A instead of ACC.

### ACC (0xE0) – Accumulator

Bit	Name	Reset	R/W	Description
7:0	ACC[7:0]	0x00	R/W	Accumulator

#### 12.5.4 B Register

The B register is used as the second 8-bit argument during execution of multiply and divide instructions. When not used for these

purposes it may be used as a scratch-pad register to hold temporary data.

## B (0xF0) – B Register

Bit	Name	Reset	R/W	Description
7:0	B[7:0]	0x00	R/W	B register. Used in MUL/DIV instructions.

### 12.5.5 Stack Pointer

The stack resides in DATA memory space and grows upwards. The `PUSH` instruction first increments the Stack Pointer (`SP`) and then copies the byte into the stack. The Stack Pointer is initialized to 0x07 after a reset and it is incremented once to start from location

0x08, which is the first register (`R0`) of the second register bank. Thus, in order to use more than one register bank, the `SP` should be initialized to a different location not used for data storage.

## SP (0x81) – Stack Pointer

Bit	Name	Reset	R/W	Description
7:0	SP[7:0]	0x07	R/W	Stack Pointer

## 12.6 Instruction Set Summary

The 8051 instruction set is summarized in

Table 31. All mnemonics copyrighted © Intel Corporation 1980.

The following conventions are used in the instruction set summary:

- Rn – Register R7-R0 of the currently selected register bank.
- direct – 8-bit internal data location's address. This can be DATA area (0x00 – 0x7F) or SFR area (0x80 – 0xFF).
- @Ri – 8-bit internal data location, DATA area (0x00 – 0xFF) addressed indirectly through register R1 or R0.
- #data – 8-bit constant included in instruction.
- #data16 – 16-bit constant included in instruction.
- addr16 – 16-bit destination address. Used by `LCALL` and `LJMP`. A valid branch can be

anywhere within the 8/16/32 KB CODE program memory space.

- addr11 – 11-bit destination address. Used by `ACALL` and `AJMP`. The branch will be within the same 2 KB page of program memory as the first byte of the following instruction.
- rel – Signed (two's complement) 8-bit offset byte. Used by `SJMP` and all conditional jumps. Range is –128 to +127 bytes relative to first byte of the following instruction.
- bit – direct addressed bit in DATA area or SFR.

The instructions that affect CPU flag settings located in `PSW` are listed in Table 32 on page 49. Note that operations on the `PSW` or bits in `PSW` will also affect the flag settings.

**Table 31. Instruction Set Summary**

Mnemonic	Description	Hex Opcode	Bytes	Cycles
<b>Arithmetic operations</b>				
ADD A,Rn	Add register to accumulator	28-2F	1	1
ADD A,direct	Add direct byte to accumulator	25	2	2
ADD A,@Ri	Add indirect RAM to accumulator	26-27	1	2
ADD A,#data	Add immediate data to accumulator	24	2	2
ADDC A,Rn	Add register to accumulator with carry flag	38-3F	1	1
ADDC A,direct	Add direct byte to A with carry flag	35	2	2
ADDC A,@Ri	Add indirect RAM to A with carry flag	36-37	1	2
ADDC A,#data	Add immediate data to A with carry flag	34	2	2
SUBB A,Rn	Subtract register from A with borrow	98-9F	1	1
SUBB A,direct	Subtract direct byte from A with borrow	95	2	2
SUBB A,@Ri	Subtract indirect RAM from A with borrow	96-97	1	2
SUBB A,#data	Subtract immediate data from A with borrow	94	2	2
INC A	Increment accumulator	04	1	1
INC Rn	Increment register	08-0F	1	2
INC direct	Increment direct byte	05	2	3
INC @Ri	Increment indirect RAM	06-07	1	3
INC DPTR	Increment data pointer	A3	1	1
DEC A	Decrement accumulator	14	1	1
DEC Rn	Decrement register	18-1F	1	2
DEC direct	Decrement direct byte	15	2	3
DEC @Ri	Decrement indirect RAM	16-17	1	3
MUL AB	Multiply A and B	A4	1	5
DIV	Divide A by B	84	1	5
DA A	Decimal adjust accumulator	D4	1	1
<b>Logical operations</b>				
ANL A,Rn	AND register to accumulator	58-5F	1	1
ANL A,direct	AND direct byte to accumulator	55	2	2
ANL A,@Ri	AND indirect RAM to accumulator	56-57	1	2
ANL A,#data	AND immediate data to accumulator	54	2	2
ANL direct,A	AND accumulator to direct byte	52	2	3
ANL direct,#data	AND immediate data to direct byte	53	3	4
ORL A,Rn	OR register to accumulator	48-4F	1	1
ORL A,direct	OR direct byte to accumulator	45	2	2
ORL A,@Ri	OR indirect RAM to accumulator	46-47	1	2
ORL A,#data	OR immediate data to accumulator	44	2	2
ORL direct,A	OR accumulator to direct byte	42	2	3
ORL direct,#data	OR immediate data to direct byte	43	3	4
XRL A,Rn	Exclusive OR register to accumulator	68-6F	1	1

Mnemonic	Description	Hex Opcode	Bytes	Cycles
XRL A,direct	Exclusive OR direct byte to accumulator	65	2	2
XRL A,@Ri	Exclusive OR indirect RAM to accumulator	66-67	1	2
XRL A,#data	Exclusive OR immediate data to accumulator	64	2	2
XRL direct,A	Exclusive OR accumulator to direct byte	62	2	3
XRL direct,#data	Exclusive OR immediate data to direct byte	63	3	4
CLR A	Clear accumulator	E4	1	1
CPL A	Complement accumulator	F4	1	1
RL A	Rotate accumulator left	23	1	1
RLC A	Rotate accumulator left through carry	33	1	1
RR A	Rotate accumulator right	03	1	1
RRC A	Rotate accumulator right through carry	13	1	1
SWAP A	Swap nibbles within the accumulator	C4	1	1
<b>Data transfers</b>				
MOV A,Rn	Move register to accumulator	E8-EF	1	1
MOV A,direct	Move direct byte to accumulator	E5	2	2
MOV A,@Ri	Move indirect RAM to accumulator	E6-E7	1	2
MOV A,#data	Move immediate data to accumulator	74	2	2
MOV Rn,A	Move accumulator to register	F8-FF	1	2
MOV Rn,direct	Move direct byte to register	A8-AF	2	4
MOV Rn,#data	Move immediate data to register	78-7F	2	2
MOV direct,A	Move accumulator to direct byte	F5	2	3
MOV direct,Rn	Move register to direct byte	88-8F	2	3
MOV direct1,direct2	Move direct byte to direct byte	85	3	4
MOV direct,@Ri	Move indirect RAM to direct byte	86-87	2	4
MOV direct,#data	Move immediate data to direct byte	75	3	3
MOV @Ri,A	Move accumulator to indirect RAM	F6-F7	1	3
MOV @Ri,direct	Move direct byte to indirect RAM	A6-A7	2	5
MOV @Ri,#data	Move immediate data to indirect RAM	76-77	2	3
MOV DPTR,#data16	Load data pointer with a 16-bit constant	90	3	3
MOVC A,@A+DPTR	Move code byte relative to DPTR to accumulator	93	1	3
MOVC A,@A+PC	Move code byte relative to PC to accumulator	83	1	3
MOVX A,@Ri	Move external RAM (8-bit address) to A	E2-E3	1	3-10
MOVX A,@DPTR	Move external RAM (16-bit address) to A	E0	1	3-10
MOVX @Ri,A	Move A to external RAM (8-bit address)	F2-F3	1	4-11
MOVX @DPTR,A	Move A to external RAM (16-bit address)	F0	1	4-11
PUSH direct	Push direct byte onto stack	C0	2	4
POP direct	Pop direct byte from stack	D0	2	3
XCH A,Rn	Exchange register with accumulator	C8-CF	1	2
XCH A,direct	Exchange direct byte with accumulator	C5	2	3
XCH A,@Ri	Exchange indirect RAM with accumulator	C6-C7	1	3
XCHD A,@Ri	Exchange low-order nibble indirect. RAM with A	D6-D7	1	3

Mnemonic	Description	Hex Opcode	Bytes	Cycles
<b>Program branching</b>				
ACALL addr11	Absolute subroutine call	xxx11	2	6
LCALL addr16	Long subroutine call	12	3	6
RET	Return from subroutine	22	1	4
RETI	Return from interrupt	32	1	4
AJMP addr11	Absolute jump	xxx01	2	3
LJMP addr16	Long jump	02	3	4
SJMP rel	Short jump (relative address)	80	2	3
JMP @A+DPTR	Jump indirect relative to the DPTR	73	1	2
JZ rel	Jump if accumulator is zero	60	2	3
JNZ rel	Jump if accumulator is not zero	70	2	3
JC rel	Jump if carry flag is set	40	2	3
JNC	Jump if carry flag is not set	50	2	3
JB bit,rel	Jump if direct bit is set	20	3	4
JNB bit,rel	Jump if direct bit is not set	30	3	4
JBC bit,direct rel	Jump if direct bit is set and clear bit	10	3	4
CJNE A,direct rel	Compare direct byte to A and jump if not equal	B5	3	4
CJNE A,#data rel	Compare immediate to A and jump if not equal	B4	3	4
CJNE Rn,#data rel	Compare immediate to reg. and jump if not equal	B8-BF	3	4
CJNE @Ri,#data rel	Compare immediate to indirect and jump if not equal	B6-B7	3	4
DJNZ Rn,rel	Decrement register and jump if not zero	D8-DF	2	3
DJNZ direct,rel	Decrement direct byte and jump if not zero	D5	3	4
NOP	No operation	00	1	1
<b>Boolean variable operations</b>				
CLR C	Clear carry flag	C3	1	1
CLR bit	Clear direct bit	C2	2	3
SETB C	Set carry flag	D3	1	1
SETB bit	Set direct bit	D2	2	3
CPL C	Complement carry flag	B3	1	1
CPL bit	Complement direct bit	B2	2	3
ANL C,bit	AND direct bit to carry flag	82	2	2
ANL C,/bit	AND complement of direct bit to carry	B0	2	2
ORL C,bit	OR direct bit to carry flag	72	2	2
ORL C,/bit	OR complement of direct bit to carry	A0	2	2
MOV C,bit	Move direct bit to carry flag	A2	2	2
MOV bit,C	Move carry flag to direct bit	92	2	3



Instruction	CY	OV	AC
ADD	x	x	x
ADDC	x	x	x
SUBB	x	x	x
MUL	0	x	
DIV	0	x	
DA	x		
RRC	x		
RLC	x		
SETB C	1		
CLR C	x		
CPL C	x		
ANL C,bit	x		
ANL C,/bit	x		
ORL C,bit	x		
ORL C,/bit	x		
MOV C,bit	x		
CJNE	x		

“0”=set to 0, “1”=set to 1, “x”=set to 0/1, “-”=not affected

**Table 32: Instructions that affect flag settings**

## 12.7 Interrupts

The CPU has 18 interrupt sources. Each source has its own request flag located in a set of Interrupt Flag SFR registers. Each interrupt requested by the corresponding flag can be individually enabled or disabled. The definitions of the interrupt sources and the interrupt vectors are given in Table 33.

I2S and USART1 share interrupts. On the CC2511Fx USB shares interrupt with Port 2 inputs. The interrupt aliases for I2S and USB are listed in Table 34. The original interrupt names, masks and flags in Table 33, however, are used in the following sections.

The interrupts are grouped into a set of priority level groups with selectable priority levels.

The interrupt enable registers are described in section 12.7.1 and the interrupt priority settings are described in section 12.7.4 on page 58.

### 12.7.1 Interrupt Masking

Each interrupt can be individually enabled or disabled by the interrupt enable bits in the Interrupt Enable SFRs IEN0, IEN1 and IEN2. The Interrupt Enable SFRs are described below and summarized in Table 33.

Note that some peripherals have several events that can generate the interrupt request associated with that peripheral. This applies to Port 0, Port 1, Port 2, DMA, Timer 1, Timer 3, Timer 4 and Radio. These peripherals have interrupt mask bits for each internal interrupt source in the corresponding SFR registers.

In order to use any of the interrupts in the *CC2510Fx/CC2511Fx* the following steps must be taken

1. Set the corresponding individual interrupt enable bit in the IEN0, IEN1 or IEN2 register to 1.
2. Set individual interrupt enable bit in the peripherals SFR register, if any.
3. Begin the interrupt service routine at the corresponding vector address of that interrupt. See Table 33 for addresses.
4. Enable global interrupt by setting the EA bit in IEN0 to 1

12.7.2 Interrupt Vector Sharing

I2S shares RX and TX interrupt vectors with USART1 and the USB Controller (on *CC2511Fx*)

shares interrupt vector with Port 2 inputs. See Table 34 for addresses.

Interrupt number	Description	Interrupt name	Interrupt Vector	Interrupt Mask	Interrupt Flag
0	RF TX done / RX ready	RFTXRX	03h	IEN0.RFTXRXIE	TCON.RFTXRXIF
1	ADC end of conversion	ADC	0Bh	IEN0.ADCIE	TCON.ADCIF
2	USART0 RX complete	URX0	13h	IEN0.URX0IE	TCON.URX0IF
3	USART1 RX complete (I2S RX complete, see Table 34)	URX1	1Bh	IEN0.URX1IE	TCON.URX1IF
4	AES encryption/decryption complete	ENC	23h	IEN0.ENCIE	SOCON.ENCIF
5	Sleep Timer compare	ST	2Bh	IEN0.STIE	IRCON.STIF
6	Port 2 inputs (Also used for USB on <i>CC2511Fx</i> , see Table 34)	P2INT	33h	IEN2.P2IE	IRCON2.P2IF
7	USART0 TX complete	UTX0	3Bh	IEN2.UTX0IE	IRCON2.UTX0IF
8	DMA transfer complete	DMA	43h	IEN1.DMAIE	IRCON.DMAIF
9	Timer 1 (16-bit) capture/Compare/overflow	T1	4Bh	IEN1.T1IE	IRCON.T1IF
10	Timer 2 (MAC Timer) overflow	T2	53h	IEN1.T2IE	IRCON.T2IF
11	Timer 3 (8-bit) capture/compare/overflow	T3	5Bh	IEN1.T3IE	IRCON.T3IF
12	Timer 4 (8-bit) capture/compare/overflow	T4	63h	IEN1.T4IE	IRCON.T4IF
13	Port 0 inputs (Note: USB Resume from suspend interrupt on P0_7 on <i>CC2511Fx</i> )	P0INT	6Bh	IEN1.P0IE	IRCON.P0IF
14	USART1 TX complete (I2S TX complete, see Table 34)	UTX1	73h	IEN2.UTX1IE	IRCON2.UTX1IF
15	Port 1 inputs	P1INT	7Bh	IEN2.P1IE	IRCON2.P1IF
16	RF general interrupts	RF	83h	IEN2.RFIE	S1CON.RFIF
17	Watchdog overflow in timer mode	WDT	8Bh	IEN2.WDTIE	IRCON2.WDTIF

Table 33: Interrupts Overview

Interrupt number	Description	Interrupt name	Interrupt Vector	Interrupt Mask Alias	Interrupt Flag Alias
3	I2S RX complete	I2SRX	1Bh	IEN0.I2SRXIE	TCON.I2SRXIF
14	I2S TX complete	I2STX	73h	IEN2.I2STXIE	IRCON2.I2STXIF
6	USB Interrupt pending ( <i>CC2511Fx</i> )	USB	33h	IEN2.USBIE	IRCON2.USBIF

Table 34: Shared Interrupt Vectors (I2S and USB)

## IEN0 (0xA8) – Interrupt Enable 0 Register

Bit	Name	Reset	R/W	Description
7	EA	0	R/W	Disables all interrupts. 0 No interrupt will be acknowledged 1 Each interrupt source is individually enabled or disabled by setting its corresponding enable bit
6	–	0	R0	Not used. Read as 0
5	STIE	0	R/W	STIE – Sleep Timer interrupt enable 0 Interrupt disabled 1 Interrupt enabled
4	ENCIE	0	R/W	ENCIE – AES encryption/decryption interrupt enable 0 Interrupt disabled 1 Interrupt enabled
3	URX1IE / I2SRXIE	0	R/W	URX1IE– USART1 RX interrupt enable / I2SRXIE – I2S RX interrupt enable 0 Interrupt disabled 1 Interrupt enabled
2	URX0IE	0	R/W	URX0IE - USART0 RX interrupt enable 0 Interrupt disabled 1 Interrupt enabled
1	ADCIE	0	R/W	ADCIE – ADC interrupt enable 0 Interrupt disabled 1 Interrupt enabled
0	RFTXRXIE	0	R/W	RFRXTXIE – RF TX/RX done interrupt enable 0 Interrupt disabled 1 Interrupt enabled

## IEN1 (0xB8) – Interrupt Enable 1 Register

Bit	Name	Reset	R/W	Description
7:6	–	00	R0	Not used. Read as 0
5	P0IE	0	R/W	P0IE – Port 0 interrupt enable 0 Interrupt disabled 1 Interrupt enabled
4	T4IE	0	R/W	T4IE - Timer 4 interrupt enable 0 Interrupt disabled 1 Interrupt enabled
3	T3IE	0	R/W	T3IE - Timer 3 interrupt enable 0 Interrupt disabled 1 Interrupt enabled
2	T2IE	0	R/W	T2IE – Timer 2 interrupt enable 0 Interrupt disabled 1 Interrupt enabled
1	T1IE	0	R/W	T1IE – Timer 1 interrupt enable 0 Interrupt disabled 1 Interrupt enabled
0	DMAIE	0	R/W	DMAIE – DMA transfer interrupt enable 0 Interrupt disabled 1 Interrupt enabled

**IEN2 (0x9A) – Interrupt Enable 2 Register**

Bit	Name	Reset	R/W	Description
7:6	–	00	R0	Not used. Read as 0
5	WDTIE	0	R/W	WDTIE – Watchdog timer interrupt enable 0 Interrupt disabled 1 Interrupt enabled
4	P1IE	0	R/W	P1IE – Port 1 interrupt enable 0 Interrupt disabled 1 Interrupt enabled
3	UTX1IE / I2STXIE	0	R/W	UTX1IE – USART1 TX interrupt enable / I2STXIE – I2S TX interrupt enable 0 Interrupt disabled 1 Interrupt enabled
2	UTX0IE	0	R/W	UTX0IE - USART0 TX interrupt enable 0 Interrupt disabled 1 Interrupt enabled
1	P2IE / USBIE	0	R/W	P2IE – Port 2 interrupt enable (Also used for USB interrupt enable on <i>CC2511Fx</i> ) 0 Interrupt disabled 1 Interrupt enabled
0	RFIE	0	R/W	RFIE – RF general interrupt enable 0 Interrupt disabled 1 Interrupt enabled

**12.7.3 Interrupt Processing**

When an interrupt occurs, the CPU will vector to the interrupt vector address as shown in Table 33. Once an interrupt service has begun, it can be interrupted only by a higher priority interrupt. The interrupt service is terminated by a `RETI` return from interrupt instruction. When a `RETI` is performed, the CPU will return to the instruction that would have been next when the interrupt occurred.

When the interrupt condition occurs, the CPU will also indicate this by setting an interrupt flag bit in the interrupt flag registers. This bit is set regardless of whether the interrupt is enabled or disabled. If the interrupt is enabled when an interrupt flag is set, then on the next instruction cycle the interrupt will be acknowledged by hardware forcing an `LCALL` to the appropriate vector address.

**Interrupt response** will require a varying amount of time depending on the state of the CPU when the interrupt occurs. If the CPU is performing an interrupt service with equal or greater priority, the new interrupt will be pending until it becomes the interrupt with highest priority. In other cases, the response time depends on current instruction. The fastest possible response to an interrupt is seven instruction cycles. This includes one instruction cycle for detecting the interrupt and six cycles to perform the `LCALL`.

**Clearing interrupt** flags must be done correctly to ensure that no interrupts are lost, and no interrupt is processed more than once. The general rule is to first clear the MCU interrupt flag, and then clear any module flags. E.g. on the RF interrupt the MCU interrupt flag located in `S1CON.RFIF` is cleared first and

then the module interrupt flags located in the RFIF register are cleared.

One or more module flags can be cleared at once. However the safest approach is to only handle one interrupt source each time the interrupt is triggered, hence clearing only one module flag. When any module flag is cleared the chip will check if there are any module interrupt flags left that are both enabled and set, if so the MCU interrupt flag will be set and a new interrupt triggered.

Example code where only one module flag is handled and cleared each time the interrupt occurs:

```
#pragma vector=RF_VECTOR
__interrupt void rf_interrupt (void)
{
    S1CON &= ~0x03;      //clear MCU interrupt flag
    if(RFIF & 0x80)      //if TX underflow
    {
        ...handle TX underflow
        RFIF = ~0x80;    //clear module interrupt flag
    }
    else if(RFIF & 0x40) //else if RX overflow
    {
        ...handle RX overflow
        RFIF = ~0x40;    //clear module interrupt flag
    }

    .....use "else if" to check and handle other RFIF flags
}
```

Some interrupts are cleared by hardware when the CPU vectors the interrupt service routine, when handling these interrupts the MCU interrupt flag should NOT be cleared in software, only clear module interrupt flags. This applies to the following interrupts:

- RFTXRX
- ADC
- URX0
- URX1/I2SRX
- T1
- T2
- T3
- T4

## TCON (0x88) – Interrupt Flag

Bit	Name	Reset	R/W	Description
7	URX1IF / I2SRXIF	0	R/W H0	URX1IF – USART1 RX interrupt flag. / I2SRXIF – I2S RX interrupt flag.  Set to 1 when USART1 RX interrupt occurs and cleared when CPU vectors to the interrupt service routine.  0 Interrupt not pending 1 Interrupt pending
6	–	0	R/W	Not used
5	ADCIF	0	R/W H0	ADCIF – ADC interrupt flag. Set to 1 when ADC interrupt occurs and cleared when CPU vectors to the interrupt service routine.  0 Interrupt not pending 1 Interrupt pending
4	–	0	R/W	Not used
3	URX0IF	0	R/W H0	URX0IF – USART0 RX interrupt flag. Set to 1 when USART0 interrupt occurs and cleared when CPU vectors to the interrupt service routine.  0 Interrupt not pending 1 Interrupt pending
2	IT1	1	R/W	Reserved. Must always be set to 1.
1	RFTXRIF	0	R/W H0	RFTXRIF – RF TX/RX complete interrupt flag. Set to 1 when RFTXRIF interrupt occurs and cleared when CPU vectors to the interrupt service routine.  0 Interrupt not pending 1 Interrupt pending
0	IT0	1	R/W	Reserved. Must always be set to 1.

## S0CON (0x98) – Interrupt Flag 2

Bit	Name	Reset	R/W	Description
7:6	–	0	R/W	Not used
1	ENCIF_1	0	R/W	ENCIF – AES interrupt. ENCIF has two interrupt flags, ENCIF_1 and ENCIF_0. Setting one of these flags will request interrupt service. Both flags are set when the AES co-processor requests the interrupt.  0 Interrupt not pending 1 Interrupt pending
0	ENCIF_0	0	R/W	ENCIF – AES interrupt. ENCIF has two interrupt flags, ENCIF_1 and ENCIF_0. Setting one of these flags will request interrupt service. Both flags are set when the AES co-processor requests the interrupt.  0 Interrupt not pending 1 Interrupt pending

## S1CON (0x9B) – Interrupt Flag 3

Bit	Name	Reset	R/W	Description
7:6	–	0	R/W	Not used
1	RFIF_1	0	R/W	RFIF – RF general interrupt. RFIF has two interrupt flags, RFIF_1 and RFIF_0. Setting one of these flags will request interrupt service. Both flags are set when the radio requests the interrupt.  0 Interrupt not pending 1 Interrupt pending
0	RFIF_0	0	R/W	RFIF – RF general interrupt. RFIF has two interrupt flags, RFIF_1 and RFIF_0. Setting one of these flags will request interrupt service. Both flags are set when the radio requests the interrupt.  0 Interrupt not pending 1 Interrupt pending



**IRCON (0xC0) – Interrupt Flag 4**

Bit	Name	Reset	R/W	Description
7	STIF	0	R/W	STIF – Sleep timer interrupt flag 0 Interrupt not pending 1 Interrupt pending
6	–	0	R/W	Not used
5	P0IF	0	R/W	P0IF – Port 0 interrupt flag 0 Interrupt not pending 1 Interrupt pending
4	T4IF	0	R/W H0	T4IF – Timer 4 interrupt flag. Set to 1 when Timer 4 interrupt occurs and cleared when CPU vectors to the interrupt service routine. 0 Interrupt not pending 1 Interrupt pending
3	T3IF	0	R/W H0	T3IF – Timer 3 interrupt flag. Set to 1 when Timer 3 interrupt occurs and cleared when CPU vectors to the interrupt service routine. 0 Interrupt not pending 1 Interrupt pending
2	T2IF	0	R/W H0	T2IF – Timer 2 interrupt flag. Set to 1 when Timer 2 interrupt occurs and cleared when CPU vectors to the interrupt service routine. 0 Interrupt not pending 1 Interrupt pending
1	T1IF	0	R/W H0	T1IF – Timer 1 interrupt flag. Set to 1 when Timer 1 interrupt occurs and cleared when CPU vectors to the interrupt service routine. 0 Interrupt not pending 1 Interrupt pending
0	DMAIF	0	R/W	DMAIF – DMA complete interrupt flag. 0 Interrupt not pending 1 Interrupt pending

IRCON2 (0xE8) – Interrupt Flag 5

Bit	Name	Reset	R/W	Description
7:5	–	00	R/W	Not used
4	WDTIF	0	R/W	WDTIF – Watchdog timer interrupt flag. 0 Interrupt not pending 1 Interrupt pending
3	P1IF	0	R/W	P1IF – Port 1 interrupt flag. 0 Interrupt not pending 1 Interrupt pending
2	UTX1IF / I2STXIF	0	R/W	UTX1IF – USART1 TX interrupt flag. / I2STXIF – I2S TX interrupt flag 0 Interrupt not pending 1 Interrupt pending
1	UTX0IF	0	R/W	UTX0IF – USART0 TX interrupt flag. 0 Interrupt not pending 1 Interrupt pending
0	P2IF / USBIF	0	R/W	P2IF – Port2 interrupt flag. / USBIF – USB interrupt flag 0 Interrupt not pending 1 Interrupt pending

12.7.4 Interrupt Priority

The interrupts are grouped into six interrupt priority groups and the priority for each group is set by the registers `IP0` and `IP1`. In order to assign a higher priority to an interrupt, i.e. to its interrupt group, the corresponding bits in `IP0` and `IP1` must be set as shown in Table 35 on page 59.

The interrupt priority groups with assigned interrupt sources are shown in Table 36. Each

group is assigned one of four priority levels. While an interrupt service request is in progress, it cannot be interrupted by a lower or same level interrupt.

In the case when interrupt requests of the same priority level are received simultaneously, the polling sequence shown in Table 37 is used to resolve the priority of each request.

**IP1 (0xB9) – Interrupt Priority 1**

Bit	Name	Reset	R/W	Description
7:6	–	00	R/W	Not used.
5	IP1_5	0	R/W	Interrupt group 5, priority control bit 1, refer to Table 35
4	IP1_4	0	R/W	Interrupt group 4, priority control bit 1, refer to Table 35
3	IP1_3	0	R/W	Interrupt group 3, priority control bit 1, refer to Table 35
2	IP1_2	0	R/W	Interrupt group 2, priority control bit 1, refer to Table 35
1	IP1_1	0	R/W	Interrupt group 1, priority control bit 1, refer to Table 35
0	IP1_0	0	R/W	Interrupt group 0, priority control bit 1, refer to Table 35

**IP0 (0xA9) – Interrupt Priority 0**

Bit	Name	Reset	R/W	Description
7:6	–	00	R/W	Not used.
5	IP0_5	0	R/W	Interrupt group 5, priority control bit 0, refer to Table 35
4	IP0_4	0	R/W	Interrupt group 4, priority control bit 0, refer to Table 35
3	IP0_3	0	R/W	Interrupt group 3, priority control bit 0, refer to Table 35
2	IP0_2	0	R/W	Interrupt group 2, priority control bit 0, refer to Table 35
1	IP0_1	0	R/W	Interrupt group 1, priority control bit 0, refer to Table 35
0	IP0_0	0	R/W	Interrupt group 0, priority control bit 0, refer to Table 35

IP1_x	IP0_x	Priority Level
0	0	0 – lowest
0	1	1
1	0	2
1	1	3 – highest

**Table 35: Priority Level Setting**

Group	Interrupts		
IP0	RFTXRX	RF	DMA
IP1	ADC	P2INT / USB	T1
IP2	URX0	UTX0	T2
IP3	URX1 / I2S	UTX1 / I2S	T3
IP4	ENC	P1INT	T4
IP5	ST	WDT	POINT

**Table 36: Interrupt Priority Groups**

Interrupt number	Interrupt name	
0	RFTXRX	Polling sequence  
16	RF	
8	DMA	
1	ADC	
9	T1	
2	URX0	
10	T2	
3	URX1 / I2S	
11	T3	
4	ENC	
12	T4	
5	ST	
13	P0INT / (USB Resume)	
6	P2INT / USB	
7	UTX0	
14	UTX1 / I2S	
15	P1INT	
17	WDT	

**Table 37: Interrupt Polling Sequence**

### 12.8 Oscillators and clocks

The *CC2510Fx/CC2511Fx* has one internal system clock. The source for the system clock can be either a 13 MHz high speed RC oscillator or a crystal oscillator. The crystal oscillator for *CC2510Fx* operates at 26 MHz while the crystal oscillator for *CC2511Fx* operates at 48 MHz. The 26 MHz clock is used directly as the system clock for *CC2510Fx*. The 48 MHz clock is used by the USB Controller only while a derived 24 MHz clock is used as

the system clock. Clock control is performed using the `CLKCON` SFR register described in section 13.10.

The choice of oscillator allows a trade-off between high-accuracy in the case of the crystal oscillator and low power consumption when the high-frequency RC oscillator is used. Note that operation of the RF transceiver and the USB requires that the crystal oscillator is used.

### 12.9 Debug Interface

The *CC2510Fx/CC2511Fx* includes a debug interface that provides a two-wire interface to an on-chip debug module. The debug interface allows programming the on-chip flash as well providing access to memory and register contents and debug features such as breakpoints, single-stepping and register modification.

The debug interface uses the I/O pins P2\_1 as Debug Data and P2\_2 as Debug Clock during Debug mode. These I/O pins can be used as general purpose I/O only while the device is not in Debug mode. Thus, the debug interface does not interfere with any peripheral I/O pins.

Debug mode is not supported in power modes 2 and 3 (PM2, PM3).

### 12.9.1 Debug Mode

Debug mode is entered by forcing two rising edge transitions on pin P2\_2 (Debug Clock) while the RESET\_N input is held low.

While in Debug mode, pin P2\_1 is the Debug Data bi-directional pin and P2\_2 is the Debug Clock input pin.

### 12.9.2 Debug Communication

The debug interface uses an SPI-like two-wire interface consisting of the Debug Data (P2\_1) and Debug Clock (P2\_2) pins. Data is driven on the bi-directional Debug Data pin at the positive edge of Debug Clock and data is sampled on the negative edge of this clock.

Debug commands are sent by an external host and consist of 1 to 4 output bytes (including command byte) from the host and an optional input byte read by the host. Figure 11 shows a timing diagram of data on the debug interface.

The first byte of the debug command is a command byte and is encoded as follows:

- bits 7 to 3 : instruction code
- bit 2 : return input byte to host when high
- bits 1 to 0 : number of output bytes from host following instruction code byte

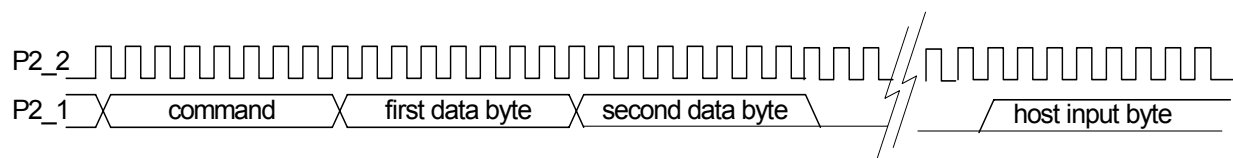

Figure 11: Debug interface timing diagram

### 12.9.3 Debug Commands

The debug commands are shown in Table 38. Some of the debug commands are described in further detail in the following sections

#### 12.9.4 Debug Lock Bit

For software code security, the Debug Interface may be locked. When the Debug Lock bit, `DBGLOCK`, is set (see section 13.16.3) all debug commands except `CHIP_ERASE`, `READ_STATUS` and `GET_CHIP_ID` are disabled and will not function.

The `CHIP_ERASE` command is used to clear the Debug Lock bit.

#### 12.9.5 Debug Configuration

The commands `WR_CONFIG` and `RD_CONFIG` are used to access the debug

configuration data byte. The format and description of this configuration data is shown in Table 39.

#### 12.9.6 Debug Status

A Debug status byte is read using the `READ_STATUS` command. The format and description of this debug status is shown in Table 40.

The `READ_STATUS` command is used e.g. for polling the status of flash chip erase after a `CHIP_ERASE` command or oscillator stable status required for debug commands `HALT`, `RESUME`, `DEBUG_INSTR`, `STEP_REPLACE` and `STEP_INSTR`.

Command	Instruction code	Description
CHIP_ERASE	0001 0x00	Perform flash chip erase (mass erase) and clear lock bits. If any other command, except READ_STATUS, is issued, then the use of CHIP_ERASE is disabled.
WR_CONFIG	0001 1x01	Write configuration data. Refer to Table 39
RD_CONFIG	0010 0100	Read configuration data. Returns value set by WR_CONFIG command.
GET_PC	0010 1000	Return value of 16-bit program counter. Returns 2 bytes regardless of value of bit 2 in instruction code
READ_STATUS	0011 0x00	Read status byte. Refer to Table 40
SET_HW_BRKPNT	0011 1x11	Set hardware breakpoint
HALT	0100 0100	Halt CPU operation
RESUME	0100 1100	Resume CPU operation. The CPU must be in halted state for this command to be run.
DEBUG_INSTR	0101 01xx	Run debug instruction. The supplied instruction will be executed by the CPU without incrementing the program counter. The CPU must be in halted state for this command to be run.
STEP_INSTR	0101 1100	Step CPU instruction. The CPU will execute the next instruction from program memory and increment the program counter after execution. The CPU must be in halted state for this command to be run.
STEP_REPLACE	0110 01xx	Step and replace CPU instruction. The supplied instruction will be executed by the CPU instead of the next instruction in program memory. The program counter will be incremented after execution. The CPU must be in halted state for this command to be run.
GET_CHIP_ID	0110 1000	Return value of 16-bit chip ID and version number. Returns 2 bytes regardless of value of bit 2 of instruction code

**Table 38: Debug Commands**

Bit	Name	Description
7-4	-	Not used
3	timers_off	Disable timers. Disable timer operation 0 Do not disable timers 1 Disable timers
2	DMA_pause	DMA pause 0 Enable DMA transfers 1 Pause all DMA transfers
1	timer_suspend	Suspend timers. Timer operation is suspended for debug instructions and if a step instruction is a branch. If not suspended these instructions would result in an extra timer count during the clock cycle in which the branch is executed 0 Do not suspend timers 1 Suspend timers
0	sel_flash_info_page	Select flash information page in order to write flash lock bits. 0 Select flash main page 1 Select flash information page

**Table 39: Debug Configuration**

Bit	Name	Description
7	chip_erase_done	Flash chip erase done 0 Chip erase in progress 1 Chip erase done
6	pcon_idle	PCON idle 0 CPU is running 1 CPU is idle (clock gated)
5	cpu_halted	CPU halted 0 CPU running 1 CPU halted
4	power_mode_0	Power Mode 0 0 Power Mode 1-3 selected 1 Power Mode 0 selected
3	halt_status	Halt status. Returns cause of last CPU halt 0 CPU was halted by HALT debug command 1 CPU was halted by software or hardware breakpoint
2	debug_locked	Debug locked. Returns value of DBGLOCK bit 0 Debug interface is not locked 1 Debug interface is locked
1	oscillator_stable	Oscillators stable. This bit represents the status of the CLKCON.XSOC_STB and CLKCON.HFRC_STB register bits. 0 Oscillators not stable 1 Oscillators stable
0	stack_overflow	Stack overflow. This bit indicates when the CPU writes to DATA memory space at address 0xFF which is possibly a stack overflow 0 No stack overflow 1 Stack overflow

Table 40: Debug Status

### 12.9.7 Hardware Breakpoints

The debug command SET\_HW\_BRKPNT is used to set a hardware breakpoint. The CC2510Fx/CC2511Fx supports up to four hardware breakpoints. When a hardware breakpoint is enabled, it will compare the CPU address bus with the breakpoint.. When a match occurs, the CPU is halted.

When issuing the SET\_HW\_BRKPNT, the external host must supply three data bytes that define the hardware breakpoint. The hardware breakpoint itself consists of 18 bits while three bits are used for control purposes. The format of the three data bytes for the SET\_HW\_BRKPNT command is as follows.

The first data byte consists of the following:

- bits 7-5 : unused
- bits 4-3 : breakpoint number; 0-3
- bit 2 : 1=enable, 0=disable
- bits 1-0 : Memory bank bits. Bits 17-16 of hardware breakpoint.

The second data byte consists of bits 15-8 of the hardware breakpoint.

The third data byte consists of bits 7-0 of the hardware breakpoint.

### 12.9.8 Flash Programming

Programming of the on-chip flash is performed via the debug interface. The external host must initially send instructions using the `DEBUG_INSTR` debug command to perform the flash programming with the Flash Controller as described in section 13.16.

### 12.10 RAM

The *CC2510Fx/CC2511Fx* contains static RAM. At power-on the contents of RAM is undefined. The RAM size is 1, 2 or 4 KB in total, mapped to the memory range 0xF000 – 0xFFFF. In the F8 and F16 versions parts of this memory range is not used.

The memory locations 0xFDA2-0xFEFF consisting of 350 bytes in XDATA memory that do not retain data when power modes PM2/3 is entered. All other RAM memory locations are retained in all power modes.

Refer to Table 28 for a description of the SRAM memory map.

### 12.11 Flash Memory

The on-chip flash memory consists of 32768 bytes. The flash memory is primarily intended to hold program code. The flash memory has the following features:

- Flash page erase time: 20 ms
- Flash chip (mass) erase time: 20 ms
- Flash write time (16 bit word): 20  $\mu$ s

- Data retention<sup>4</sup>:100 years
- Program/erase endurance: Minimum 1,000 cycles

The flash memory consists of the Flash Main Page which is where the CPU reads program code and data. The flash memory also contains a Flash Information Page which contains the Flash Lock Bits. The Flash Information Page and hence the Lock Bits is only accessed by first selecting this page through the Debug Interface. The Flash Controller (see section 13.16) is used to write and erase the contents of the flash memory.

When the CPU reads instructions from flash memory, it fetches the next instruction through a cache. The instruction cache is provided mainly to reduce power consumption by reducing the amount of time the flash memory itself is accessed. The use of the instruction cache may be disabled with the `MEMCTR.CACHDIS` register bit.

### 12.12 Memory Arbiter

The *CC2510Fx/CC2511Fx* includes a memory arbiter which handles CPU and DMA access to all memory space.

A control register `MEMCTR` is used to control the flash cache. The `MEMCTR` register is described below.

---

<sup>4</sup> At room temperature



## MEMCTR (0xC7) – Memory Arbiter Control

Bit	Name	Reset	R/W	Description
7:6	–	00	R0	Not used
5:4	–	01	R/W	Not used. Must always be set to 01.
3:2	–	00	R0	Not used
1	CACHDIS	0	R/W	Flash cache disable. Invalidates contents of instruction cache and forces all instruction read accesses to read straight from flash memory. Disabling will increase power consumption and is provided for debug purposes.  0 Cache enabled 1 Cache disabled
0	PREFDIS	0	R/W	Flash pre-fetch disable. Disables pre-fetching of cache read data. Disabling will reduce performance and is provided for debug purposes.  0 Flash pre-fetch enabled 1 Flash pre-fetch disabled

## 13 Peripherals

In the following sub-sections, each *CC2510Fx/CC2511Fx* peripheral is described in detail.

The *CC2510Fx/CC2511Fx* has four timers. These timers all run on the tick frequency given by the Power Management Controller register `CLKCON.TICKSPD`.

### 13.1 I/O ports

*Note: Note: P0\_6 and P0\_7 does not exist on CC2511Fx. The CC2511Fx has 19 digital input/output pins available and the ADC inputs 6 and 7 cannot be used. Apart from this, all information in this section applies to both CC2511Fx and CC2510Fx.*

The *CC2510Fx* has 21 digital input/output pins that can be configured as general purpose digital I/O or as peripheral I/O signals connected to the ADC, Timers, I2S or USART peripherals. The usage of the I/O ports is fully configurable from user software through a set of configuration registers.

The I/O ports have the following key features:

- 21 digital input/output pins
- General purpose I/O or peripheral I/O
- Pull-up or pull-down capability on inputs, except P1\_0 and P1\_1.
- External interrupt capability

The external interrupt capability is available on all 21 I/O pins. Thus, external devices may generate interrupts if required. The external interrupt feature can also be used to wake up from sleep modes.

#### 13.1.1 General Purpose I/O

When used as general purpose I/O, the pins are organized as three 8-bit ports, ports 0-2, denoted P0, P1 and P2. P0 and P1 are complete 8-bit wide ports while P2 has only five usable bits (P2\_0 to P2\_4). All ports are both bit- and byte addressable through the SFR registers `P0`, `P1` and `P2`. Each port pin can individually be set to operate as a general purpose I/O or as a peripheral I/O.

The output drive strength is 4 mA on all outputs, except for the two high-drive outputs, P1\_0 and P1\_1, which each have 20 mA output drive strength.

To use a port as a general purpose I/O pin the pin must first be configured. The registers `PxSEL` where x is the port number 0-2 are used to configure each pin in a port either as a general purpose I/O pin or as a peripheral I/O signal. By default, after a reset, all digital input/output pins are configured as general-purpose I/O pins.

By default, all general-purpose I/O pins are configured as inputs. To change the direction of a port pin, at any time, the registers `PxDIR` are used to set each port pin to be either an input or an output. Thus by setting the appropriate bit within `PxDIR` to 1, the corresponding pin becomes an output.

When reading the port registers `P0`, `P1` and `P2`, the logic values on the input pins are returned regardless of the pin configuration. This does not apply during the execution of read-modify-write instructions. The read-modify-write instructions when operating on a port registers are the following: `ANL`, `ORL`, `XRL`, `JBC`, `CPL`, `INC`, `DEC`, `DJNZ` and `MOV`, `CLR` or `SETB`, when the destination is an individual bit in a port register `P0`, `P1` or `P2`. For these read-modify-write instructions, the value of the register, not the value on the pin, is read, modified, and written back to the port register.

When used as an input, the general purpose I/O port pins can be configured to have a pull-up, pull-down or tri-state mode of operation. By default, after a reset, inputs are configured as inputs with pull-up. To deselect the pull-up/pull-down function on an input the appropriate bit within the `PxINP` must be set to 1. The I/O port pins P1\_0 and P1\_1 do not have pull-up/pull-down capability.

In power modes PM1, PM2 and PM3 the I/O pins retain the I/O mode and output value (if applicable) that was set when PM1/2/3 was entered.

#### 13.1.2 General Purpose I/O Interrupts

General purpose I/O pins configured as inputs can be used to generate interrupts. The interrupts can be configured to trigger on either a rising or falling edge of the external signal. Each of the `P0`, `P1` and `P2` ports have separate interrupt enable bits common for all bits within the port located in the `IEN1-2` registers as follows:

- `IEN1.P0IE` : P0 interrupt enable
- `IEN2.P1IE` : P1 interrupt enable
- `IEN2.P2IE` : P2 interrupt enable

In addition to these common interrupt enables, the bits within each port have interrupt enables located in I/O port SFR registers. Each bit within `P1` has an individual interrupt enable. In `P0` the low-order nibble and the high-order nibble have their individual interrupt enables. For the `P2_0 – P2_4` inputs there is a common interrupt enable.

When an interrupt condition occurs on one of the general purpose I/O pins, the corresponding interrupt status flag in the `P0-P2` interrupt flag registers, `P0IFG`, `P1IFG` or `P2IFG` will be set to 1. The interrupt status flag is set regardless of whether the pin has its interrupt enable set. When an interrupt is serviced the interrupt status flag is cleared by writing a 0 to that flag.

The SFR registers used for I/O interrupts are described in section 12.7 on page 49. The registers are summarized below:

- `P1IEN` : P1 interrupt enables
- `P1CTL` : P0/P2 interrupt enables and P0-2 edge configuration
- `P0IFG` : P0 interrupt flags
- `P1IFG` : P1 interrupt flags
- `P2IFG` : P2 interrupt flags

### 13.1.3 General Purpose I/O DMA

When used as general purpose I/O pins, the `P0` and `P1` ports are each associated with one DMA trigger. These DMA triggers are `IOC_0` for `P0` and `IOC_1` for `P1` as shown in Table 42 on page 90.

The `IOC_0` or `IOC_1` DMA trigger is activated when an input transition occurs on one of the `P0` or `P1` pins respectively. Note that only input transitions on pins configured as general purpose I/O inputs, will produce the DMA trigger.

### 13.1.4 Peripheral I/O

This section describes how the digital input/output pins are configured as peripheral I/Os. For each peripheral unit that can interface with an external system through the digital input/output pins, a description of how peripheral I/Os are configured is given in the following sub-sections.

In general, setting the appropriate `PxSEL` bits to 1 is required to select peripheral I/O function on a digital I/O pin.

Note that peripheral units have two alternative locations for their I/O pins, refer to Table 41. The location to be used is selected by writing to `PERCFG`.

It is possible to set `PERCFG` so that several peripherals are assigned to the same port pins. In such cases a set of peripheral priority control bits select the order of precedence between up to two peripherals at a time, when these are assigned to the same port pins.

Table 41: Peripheral I/O Pin Mapping

Periphery / Function	P0								P1								P2				
	7 <sup>1</sup>	6 <sup>1</sup>	5	4	3	2	1	0	7	6	5	4	3	2	1	0	4	3	2	1	0
ADC	A7	A6	A5	A4	A3	A2	A1	A0													
USART0 Alt. 1			C	SS	M0	MI															
SPI Alt. 2											MO	MI	C	SS							
USART0 Alt. 1					TX	RX															
UART Alt. 2											TX	RX									
USART1 Alt. 1			MI	M0	C	SS															
SPI Alt. 2									MI	M0	C	SS									
USART1 Alt. 1			RX	TX																	
UART Alt. 2									RX	TX											
TIMER1 Alt. 1				2	1	0															
Alt. 2														0	1	2					
TIMER3 Alt. 1											1	0									
Alt. 2									1	0											
TIMER4 Alt. 1														1	0						
Alt. 2																	1				0
I2S Alt. 1							CK	WS	RX	TX											
Alt. 2																	CK	WS	RX	TX	
32.768kHz XOSC																	Q2	Q1			
DEBUG																			D	D	
																			C	D	

<sup>1</sup> This pin is only found on *CC2510Fx*, it does not exist on *CC2511Fx*.

### 13.1.4.1 USART0

The SFR register bit `PERCFG.U0CFG` selects whether to use alternative 1 or alternative 2 locations. Note that if both USARTs are used, they must be on different ports, i.e. one on P0 and one on P1. This applies both in UART and SPI mode.

In Table 41, the USART0 signals are shown as follows:

UART:

- RX : RXDATA
- TX : TXDATA

SPI:

- MI : MISO
- MO : MOSI
- C : SCK

- SS : SSN

`P2DIR.PRI0` selects the order of precedence when assigning several peripherals to port 0, i.e. the situation when several peripherals are assigned to the same pin locations. When set to 00, USART0 has precedence. Note that if UART mode is selected, USART1 or timer 1 will have precedence to use ports P0\_4 and P0\_5.

`P2SEL.PRI3P1` and `P2SEL.PRI0P1` select the order of precedence when assigning several peripherals to port 1. USART0 has precedence when both are set to 0. Note that if UART mode is selected, timer 1 or timer 3 will have precedence to use ports P1\_2 and P1\_3.

### 13.1.4.2 USART1

The SFR register bit `PERCFG.U1CFG` selects whether to use alternative 1 or alternative 2

locations. Note that if both USARTs are used, they must be on different ports, i.e. one on P0 and one on P1. This applies both in UART and SPI mode.

In Table 41, the USART1 signals are shown as follows:

- RX : RXDATA
- TX : TXDATA

SPI:

- MI : MISO
- MO : MOSI
- C : SCK
- SS : SSN

P2DIR.PRI0 selects the order of precedence when assigning several peripherals to port 0. When set to 01, USART1 has precedence. Note that if UART mode is selected, USART0 or timer 1 will have precedence to use ports P0\_2 and P0\_3.

P2SEL.PRI3P1 and P2SEL.PRI2P1 select the order of precedence when assigning several peripherals to port 1. USART1 has precedence when the former is set to 1 and the latter is set to 0. Note that if UART mode is selected, USART0 or timer 3 will have precedence to use ports P2\_4 and P2\_5.

### 13.1.4.3 Timer 1

PERCFG.T1CFG selects whether to use alternative 1 or alternative 2 locations.

In Table 41, the Timer 1 signals are shown as the following:

- 0 : Channel 0 capture/compare pin
- 1 : Channel 1 capture/compare pin
- 2 : Channel 2 capture/compare pin

P2DIR.PRI0 selects the order of precedence when assigning several peripherals to port 0. When set to 10 or 11 the timer 1 channels have precedence.

P2SEL.PRI1P1 and P2SEL.PRI0P1 select the order of precedence when assigning several peripherals to port 1. The timer 1 channels have precedence when the former is set low and the latter is set high.

### 13.1.4.4 Timer 3

PERCFG.T3CFG selects whether to use alternative 1 or alternative 2 locations.

In Table 41, the Timer 3 signals are shown as the following:

- 0 : Channel 0 capture/compare pin
- 1 : Channel 1 capture/compare pin

P2SEL.PRI2P1 selects the order of precedence when assigning several peripherals to port 1. The timer 3 channels have precedence when the bit is set.

### 13.1.4.5 Timer 4

PERCFG.T4CFG selects whether to use alternative 1 or alternative 2 locations.

In Table 41, the Timer 4 signals are shown as the following:

- 0 : Channel 0 capture/compare pin
- 1 : Channel 1 capture/compare pin

P2SEL.PRI1P1 selects the order of precedence when assigning several peripherals to port 1. The timer 4 channels have precedence when the bit is set.

### 13.1.4.6 I2S

The I2S configuration register bit I2SCFG1.IOLOC selects whether to use alternative 1 or alternative 2 locations.

In Table 41, the I2S signals are shown as follows:

- CK : Continuous Serial Clock (SCK)
- WS : Word Select
- RX : Serial Data In
- TX : Serial Data Out

### 13.1.5 ADC

When using the ADC in an application, the Port 0 pins used must be configured as ADC inputs. Up to eight ADC inputs can be used. The port pins are mapped to the ADC inputs so that P0\_7 – P0\_0 corresponds to AIN7-AIN0. To configure a Port 0 pin to be used as an ADC input the corresponding bit in the ADCCFG register must be set to 1. The default values in this register select the Port 0 pins as non-ADC input i.e. digital input/outputs. The settings in the ADCCFG register override the settings in P0SEL.

The ADC can be configured to use the general-purpose I/O pin P2\_0 as an external trigger to start conversions. P2\_0 must be configured as a general-purpose I/O in input mode, when being used for ADC external trigger.

Refer to section 13.7 on page 127 for a detailed description of use of the ADC.

### 13.1.6 Debug interface

Port pins P2\_1 and P2\_2 are used for debug data and clock signals, respectively. These are shown as DD (debug data) and DC (debug clock) in Table 41. When the debug interface is in use, P2DIR should select these pins as inputs. The state of P2SEL is overridden by the debug interface. Also, the direction is overridden when the chip changes the direction to supply the external host with data.

### 13.1.7 32.768 kHz XOSC input

Ports P2\_3 and P2\_4 are used to connect an external 32.768 kHz crystal. These port pins will be used by the 32.768 kHz crystal oscillator when CLKCON.OSC32K is low, regardless of register settings. The port pins will be set in analog mode when CLKCON.OSC32K is low.

### 13.1.8 Unused I/O pins

Unused I/O pins should have a defined level and not be left floating. One way to do this is to leave the pin unconnected and configure the pin as a general purpose I/O input with pull-up resistor. This is also the state of all pins during reset (except P1\_0 and P1\_1 which do not have pull-up/pull-down resistors). Alternatively the pin can be configured as a general purpose I/O output. In both cases the pin should not be connected directly to VDD or GND in order to avoid excessive power consumption.

### 13.1.9 IOC registers

The registers for the IO ports are described in this section. The registers are:

- P0 Port 0
- P1 Port 1
- P2 Port 2
- PERCFG Peripheral control register
- ADCCFG ADC input configuration register
- P0SEL Port 0 function select register
- P1SEL Port 1 function select register
- P2SEL Port 2 function select register
- P0DIR Port 0 direction register
- P1DIR Port 1 direction register
- P2DIR Port 2 direction register
- P0INP Port 0 input mode register
- P1INP Port 1 input mode register
- P2INP Port 2 input mode register
- P0IFG Port 0 interrupt status flag register
- P1IFG Port 1 interrupt status flag register
- P2IFG Port 2 interrupt status flag register
- PICTL Interrupt mask and edge register
- P1IEN Port 1 interrupt mask register

## P0 (0x80) – Port 0

Bit	Name	Reset	R/W	Description
7:0	P0[7:0]	0xFF	R/W	Port 0. General purpose I/O port. Bit-addressable.

## P1 (0x90) – Port 1

Bit	Name	Reset	R/W	Description
7:0	P1[7:0]	0xFF	R/W	Port 1. General purpose I/O port. Bit-addressable.

## P2 (0xA0) – Port 2

Bit	Name	Reset	R/W	Description
7:0	–	000	R0	Not used
4:0	P2[4:0]	0x1F	R/W	Port 2. General purpose I/O port. Bit-addressable.

## PERCFG (0xF1) – Peripheral Control

Bit	Name	Reset	R/W	Description
7	–	0	R0	Not used
6	T1CFG	0	R/W	Timer 1 I/O location 0 Alternative 1 location 1 Alternative 2 location
5	T3CFG	0	R/W	Timer 3 I/O location 0 Alternative 1 location 1 Alternative 2 location
4	T4CFG	0	R/W	Timer 4 I/O location 0 Alternative 1 location 1 Alternative 2 location
3:2	–	00	R0	Not used
1	U1CFG	0	R/W	USART1 I/O location 0 Alternative 1 location 1 Alternative 2 location
0	U0CFG	0	R/W	USART0 I/O location 0 Alternative 1 location 1 Alternative 2 location

## ADCCFG (0xF2) – ADC Input Configuration

Bit	Name	Reset	R/W	Description
7:0	ADCCFG[7:0]	0x00	R/W	ADC input configuration. ADCCFG[7:0] shall select P0_7 - P0_0 as ADC inputs AIN7 – AIN0 0 ADC input disabled 1 ADC input enabled

## P0SEL (0xF3) – Port 0 Function Select

Bit	Name	Reset	R/W	Description
7	SELP0_7	0	R/W	P0_7 function select 0 General purpose I/O 1 Peripheral function
6	SELP0_6	0	R/W	P0_6 function select 0 General purpose I/O 1 Peripheral function
5	SELP0_5	0	R/W	P0_5 function select 0 General purpose I/O 1 Peripheral function
4	SELP0_4	0	R/W	P0_4 function select 0 General purpose I/O 1 Peripheral function
3	SELP0_3	0	R/W	P0_3 function select 0 General purpose I/O 1 Peripheral function
2	SELP0_2	0	R/W	P0_2 function select 0 General purpose I/O 1 Peripheral function
1	SELP0_1	0	R/W	P0_1 function select 0 General purpose I/O 1 Peripheral function
0	SELP0_0	0	R/W	P0_0 function select 0 General purpose I/O 1 Peripheral function



## P1SEL (0xF4) – Port 1 Function Select

Bit	Name	Reset	R/W	Description
7	SELP1_7	0	R/W	P1_7 function select 0 General purpose I/O 1 Peripheral function
6	SELP1_6	0	R/W	P1_6 function select 0 General purpose I/O 1 Peripheral function
5	SELP1_5	0	R/W	P1_5 function select 0 General purpose I/O 1 Peripheral function
4	SELP1_4	0	R/W	P1_4 function select 0 General purpose I/O 1 Peripheral function
3	SELP1_3	0	R/W	P1_3 function select 0 General purpose I/O 1 Peripheral function
2	SELP1_2	0	R/W	P1_2 function select 0 General purpose I/O 1 Peripheral function
1	SELP1_1	0	R/W	P1_1 function select 0 General purpose I/O 1 Peripheral function
0	SELP1_0	0	R/W	P1_0 function select 0 General purpose I/O 1 Peripheral function

## P2SEL (0xF5) – Port 2 Function Select

Bit	Name	Reset	R/W	Description
7	–	0	R0	Not used
6	PRI3P1	0	R/W	Port 1 peripheral priority control. These bits shall determine the order of priority in the case when PERCFG assigns USART0 and USART1 to the same pins. 0 USART0 has priority 1 USART1 has priority
5	PRI2P1	0	R/W	Port 1 peripheral priority control. These bits shall determine the order of priority in the case when PERCFG assigns USART1 and timer 3 to the same pins. 0 USART1 has priority 1 Timer 3 has priority
4	PRI1P1	0	R/W	Port 1 peripheral priority control. These bits shall determine the order of priority in the case when PERCFG assigns timer 1 and timer 4 to the same pins. 0 Timer 1 has priority 1 Timer 4 has priority
3	PRI0P1	0	R/W	Port 1 peripheral priority control. These bits shall determine the order of priority in the case when PERCFG assigns USART0 and timer 1 to the same pins. 0 USART0 has priority 1 Timer 1 has priority
2	SELP2_4	0	R/W	P2_4 function select 0 General purpose I/O 1 Peripheral function
1	SELP2_3	0	R/W	P2_3 function select 0 General purpose I/O 1 Peripheral function
0	SELP2_0	0	R/W	P2_0 function select 0 General purpose I/O 1 Peripheral function

## P0DIR (0xFD) – Port 0 Direction

Bit	Name	Reset	R/W	Description
7	DIRP0_7	0	R/W	P0_7 I/O direction 0 Input 1 Output
6	DIRP0_6	0	R/W	P0_6 I/O direction 0 Input 1 Output
5	DIRP0_5	0	R/W	P0_5 I/O direction 0 Input 1 Output
4	DIRP0_4	0	R/W	P0_4 I/O direction 0 Input 1 Output
3	DIRP0_3	0	R/W	P0_3 I/O direction 0 Input 1 Output
2	DIRP0_2	0	R/W	P0_2 I/O direction 0 Input 1 Output
1	DIRP0_1	0	R/W	P0_1 I/O direction 0 Input 1 Output
0	DIRP0_0	0	R/W	P0_0 I/O direction 0 Input 1 Output

## P1DIR (0xFE) – Port 1 Direction

Bit	Name	Reset	R/W	Description
7	DIRP1_7	0	R/W	P1_7 I/O direction 0 Input 1 Output
6	DIRP1_6	0	R/W	P1_6 I/O direction 0 Input 1 Output
5	DIRP1_5	0	R/W	P1_5 I/O direction 0 Input 1 Output
4	DIRP1_4	0	R/W	P1_4 I/O direction 0 Input 1 Output
3	DIRP1_3	0	R/W	P1_3 I/O direction 0 Input 1 Output
2	DIRP1_2	0	R/W	P1_2 I/O direction 0 Input 1 Output
1	DIRP1_1	0	R/W	P1_1 I/O direction 0 Input 1 Output
0	DIRP1_0	0	R/W	P1_0 I/O direction 0 Input 1 Output

## P2DIR (0xFF) – Port 2 Direction

Bit	Name	Reset	R/W	Description
7:6	PRIP0[1:0]	0	R/W	Port 0 peripheral priority control. These bits shall determine the order of priority in the case when PERCFG assigns several peripherals to the same pins 00 USART0 – USART1 01 USART1 – USART0 10 Timer 1 channels 0 and 1 – USART1 11 Timer 1 channel 2 – USART0
5	–	0	R0	Not used
4	DIRP2_4	0	R/W	P2_4 I/O direction 0 Input 1 Output
3	DIRP2_3	0	R/W	P2_3 I/O direction 0 Input 1 Output
2	DIRP2_2	0	R/W	P2_2 I/O direction 0 Input 1 Output
1	DIRP2_1	0	R/W	P2_1 I/O direction 0 Input 1 Output
0	DIRP2_0	0	R/W	P2_0 I/O direction 0 Input 1 Output

## P0INP (0x8F) – Port 0 Input Mode

Bit	Name	Reset	R/W	Description
7	MDP0_7	0	R/W	P0_7 I/O input mode 0 Pull-up / pull-down 1 Tristate
6	MDP0_6	0	R/W	P0_6 I/O input mode 0 Pull-up / pull-down 1 Tristate
5	MDP0_5	0	R/W	P0_5 I/O input mode 0 Pull-up / pull-down 1 Tristate
4	MDP0_4	0	R/W	P0_4 I/O input mode 0 Pull-up / pull-down 1 Tristate
3	MDP0_3	0	R/W	P0_3 I/O input mode 0 Pull-up / pull-down 1 Tristate
2	MDP0_2	0	R/W	P0_2 I/O input mode 0 Pull-up / pull-down 1 Tristate
1	MDP0_1	0	R/W	P0_1 I/O input mode 0 Pull-up / pull-down 1 Tristate
0	MDP0_0	0	R/W	P0_0 I/O input mode 0 Pull-up / pull-down 1 Tristate

## P1INP (0xF6) – Port 1 Input Mode

Bit	Name	Reset	R/W	Description
7	MDP1_7	0	R/W	P1_7 I/O input mode 0 Pull-up / pull-down 1 Tristate
6	MDP1_6	0	R/W	P1_6 I/O input mode 0 Pull-up / pull-down 1 Tristate
5	MDP1_5	0	R/W	P1_5 I/O input mode 0 Pull-up / pull-down 1 Tristate
4	MDP1_4	0	R/W	P1_4 I/O input mode 0 Pull-up / pull-down 1 Tristate
3	MDP1_3	0	R/W	P1_3 I/O input mode 0 Pull-up / pull-down 1 Tristate
2	MDP1_2	0	R/W	P1_2 I/O input mode 0 Pull-up / pull-down 1 Tristate
1:0	–	00	R0	Not used

## P2INP (0xF7) – Port 2 Input Mode

Bit	Name	Reset	R/W	Description
7	PDUP2	0	R/W	Port 2 pull-up/down select. Selects function for all Port 2 pins configured as pull-up/pull-down inputs. 0 Pull-up 1 Pull-down
6	PDUP1	0	R/W	Port 1 pull-up/down select. Selects function for all Port 1 pins configured as pull-up/pull-down inputs. 0 Pull-up 1 Pull-down
5	PDUP0	0	R/W	Port 0 pull-up/down select. Selects function for all Port 0 pins configured as pull-up/pull-down inputs. 0 Pull-up 1 Pull-down
4	MDP2_4	0	R/W	P2_4 I/O input mode 0 Pull-up / pull-down 1 Tristate
3	MDP2_3	0	R/W	P2_3 I/O input mode 0 Pull-up / pull-down 1 Tristate
2	MDP2_2	0	R/W	P2_2 I/O input mode 0 Pull-up / pull-down 1 Tristate
1	MDP2_1	0	R/W	P2_1 I/O input mode 0 Pull-up / pull-down 1 Tristate
0	MDP2_0	0	R/W	P2_0 I/O input mode 0 Pull-up / pull-down 1 Tristate



## P0IFG (0x89) – Port 0 Interrupt Status Flag

*CC2510Fx.*

Bit	Name	Reset	R/W	Description
7:0	P0IF[7:0]	0x00	R/W0	Port 0, inputs 7 to 0 interrupt status flags. When an input port pin has an interrupt request pending, the corresponding flag bit will be set.

*CC2511Fx.*

Bit	Name	Reset	R/W	Description
7	USB_RESUME	0	R/W0	USB Resume detected during suspend.
6	–	0	R0	Not used
5:0	P0IF[5:0]	0x00	R/W0	Port 0, inputs 7 to 0 interrupt status flags. When an input port pin has an interrupt request pending, the corresponding flag bit will be set.

## P1IFG (0x8A) – Port 1 Interrupt Status Flag

Bit	Name	Reset	R/W	Description
7:0	P1IF[7:0]	0x00	R/W0	Port 1, inputs 7 to 0 interrupt status flags. When an input port pin has an interrupt request pending, the corresponding flag bit will be set.

## P2IFG (0x8B) – Port 2 Interrupt Status Flag

Bit	Name	Reset	R/W	Description
7:5	–	000	R0	Not used.
4:0	P2IF[4:0]	0x00	R/W0	Port 2, inputs 4 to 0 interrupt status flags. When an input port pin has an interrupt request pending, the corresponding flag bit will be set.

## PICTL (0x8C) – Port Interrupt Control

Bit	Name	Reset	R/W	Description
7	–	0	R0	Not used
6	–	0	R/W	Reserved. Write 0
5	P2IEN	0	R/W	Port 2, inputs 4 to 0 interrupt enable. This bit enables interrupt requests for the port 2 inputs 4 to 0. 0 Interrupts are disabled 1 Interrupts are enabled
4	P0IENH	0	R/W	Port 0, inputs 7 to 4 interrupt enable. This bit enables interrupt requests for the port 0 inputs 7 to 4. 0 Interrupts are disabled 1 Interrupts are enabled
3	P0IENL	0	R/W	Port 0, inputs 3 to 0 interrupt enable. This bit enables interrupt requests for the port 0 inputs 3 to 0. 0 Interrupts are disabled 1 Interrupts are enabled
2	P2ICON	0	R/W	Port 2, inputs 4 to 0 interrupt configuration. This bit selects the interrupt request condition for all port 2 inputs 0 Rising edge on input gives interrupt 1 Falling edge on input gives interrupt
1	P1ICON	0	R/W	Port 1, inputs 7 to 0 interrupt configuration. This bit selects the interrupt request condition for all port 1 inputs 0 Rising edge on input gives interrupt 1 Falling edge on input gives interrupt
0	P0ICON	0	R/W	Port 0, inputs 7 to 0 interrupt configuration. This bit selects the interrupt request condition for all port 0 inputs. For <i>CC2511Fx</i> this bit must not be set to 1 when USB is used, since the internal USB resume interrupt mapped to P0[7] uses rising edge. 0 Rising edge on input gives interrupt 1 Falling edge on input gives interrupt

## P1IEN (0x8D) – Port 1 Interrupt Mask

Bit	Name	Reset	R/W	Description
7	P1_7IEN	0	R/W	Port P1_7 interrupt enable 0 Interrupts are disabled 1 Interrupts are enabled
6	P1_6IEN	0	R/W	Port P1_6 interrupt enable 0 Interrupts are disabled 1 Interrupts are enabled
5	P1_5IEN	0	R/W	Port P1_5 interrupt enable 0 Interrupts are disabled 1 Interrupts are enabled
4	P1_4IEN	0	R/W	Port P1_4 interrupt enable 0 Interrupts are disabled 1 Interrupts are enabled
3	P1_3IEN	0	R/W	Port P1_3 interrupt enable 0 Interrupts are disabled 1 Interrupts are enabled
2	P1_2IEN	0	R/W	Port P1_2 interrupt enable 0 Interrupts are disabled 1 Interrupts are enabled
1	P1_1IEN	0	R/W	Port P1_1 interrupt enable 0 Interrupts are disabled 1 Interrupts are enabled
0	P1_0IEN	0	R/W	Port P1_0 interrupt enable 0 Interrupts are disabled 1 Interrupts are enabled

## 13.2 DMA Controller

The *CC2510Fx/CC2511Fx* includes a direct memory access (DMA) controller, which can be used to relieve the 8051 CPU core of handling data movement operations. Thus the *CC2510Fx/CC2511Fx* can achieve high overall performance with good power efficiency. The DMA controller can move data from a peripheral unit such as ADC or RF transceiver to memory with minimum CPU intervention.

The DMA controller module coordinates all DMA transfers, ensuring that DMA requests are prioritized appropriately relative to each other and CPU memory access. The DMA controller contains a number of programmable DMA channels for memory-to-memory data movement.

The DMA controller controls data movement over the entire XDATA memory space. Since all the SFR registers (except some internal registers) are mapped into the DMA memory space these flexible DMA channels can be used to unburden the 8051 in innovative ways, e.g. feed a USART and I2S with data from memory, periodically transfer samples between ADC and memory, transfer data to and from USB FIFOs (*CC2511Fx*) etc. Use of the DMA can also reduce system power consumption by letting the CPU run on a lower frequency (`CLKCON.CLKSPD`).

The main features of the DMA controller are as follows:

- Five independent DMA channels
- Three configurable levels of DMA channel priority
- 30 configurable transfer trigger events
- Independent control of source and destination address

- Single, block and repeated transfer modes
- Supports variable transfer length by including the length field in the transfer data
- Can operate in either word-size or byte-size mode

### 13.2.1 DMA Operation

There are five DMA channels available in the DMA controller numbered channel 0 to channel 4. Each DMA channel can move data from one place within the DMA memory space to another.

In order to use a DMA channel it must first be configured as described in sections 13.2.2 and 13.2.3.

Once a DMA channel has been configured it must be armed before any transfers are allowed to be initiated. A DMA channel is armed by setting the appropriate bit in the DMA Channel Arm register `DMAARM`.

When a DMA channel is armed a transfer will begin when the configured DMA trigger event occurs. There are 30 possible DMA trigger events, e.g. UART transfer, Timer overflow etc. The trigger event to be used by a DMA channel is set by the DMA channel configuration. The DMA trigger events are listed in Table 42.

In addition to starting a DMA transfer through the DMA trigger events, the user software may force a DMA transfer to begin by setting the corresponding `DMAREQ` bit.

Figure 12 shows the DMA state diagram.

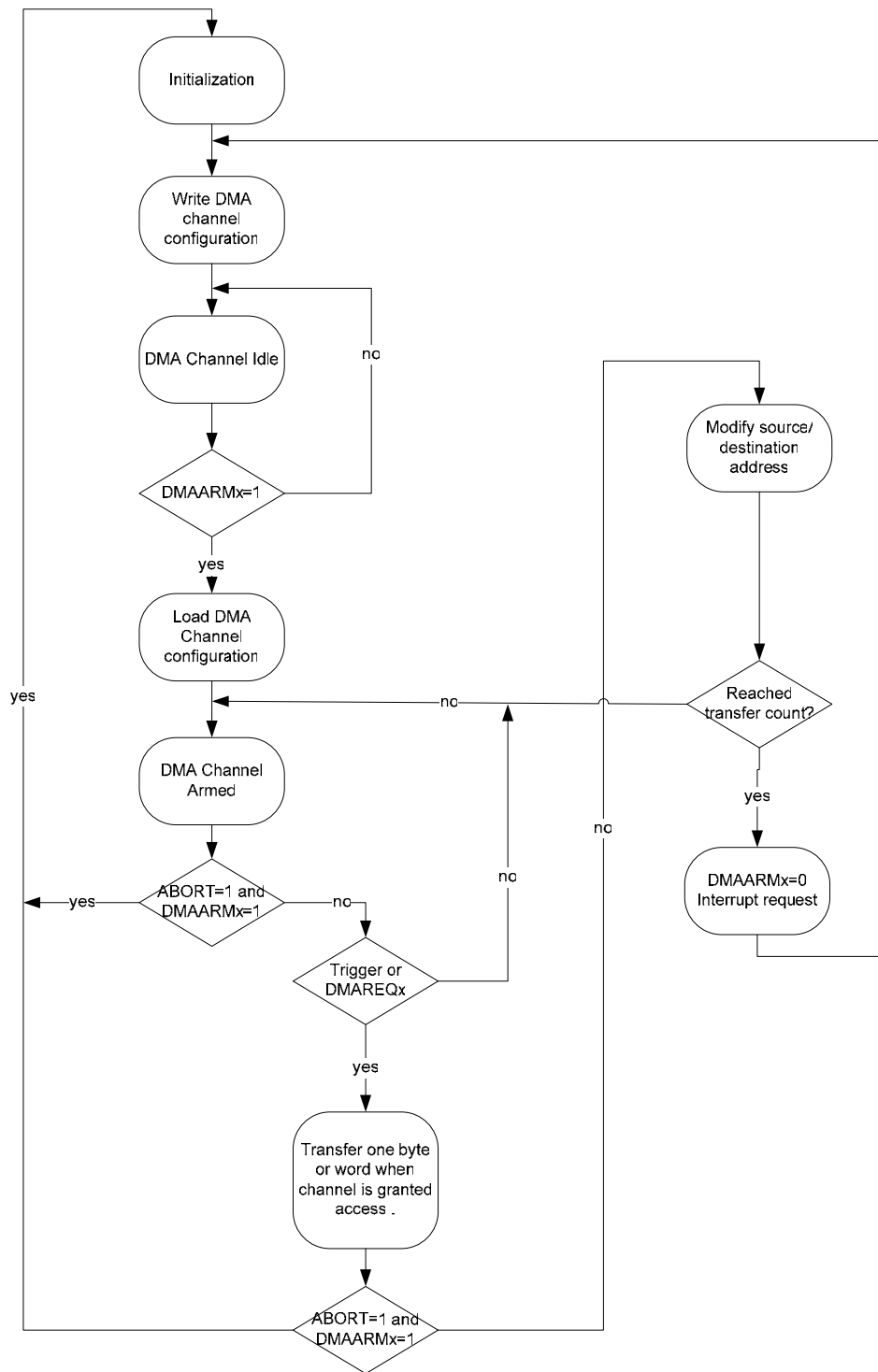

Figure 12: DMA Operation

13.2.2 DMA Configuration Parameters

Setup and control of the DMA operation is performed by the user software. This section

describes the parameters that must be configured before a DMA channel can be used. Section 13.2.3 on page 88 describes

how the parameters are set up in software and passed to the DMA controller.

The behavior of each of the five DMA channels is configured with the following parameters:

**Source address.** The first address from which the DMA channel should read data.

**Destination address.** The first address to which the DMA channel should write the data read from the source address. The user must ensure that the destination is writable.

**Transfer count.** The number of transfers to perform before rearming or disarming the DMA channel and alerting the CPU with an interrupt request. The length can be defined in the configuration or it can be defined as described next as VLEN setting.

**VLEN setting.** The DMA channel is capable of variable length transfers using the first byte or word at the source address to set the transfer length. When doing this, various options regarding how to count number of bytes to transfer are available.

**Priority.** The priority of the DMA transfers for the DMA channel in respect to the CPU and other DMA channels and access ports.

**Trigger event.** All DMA transfers are initiated by so-called DMA trigger events. This trigger either starts a DMA block transfer or a single DMA transfer.

**Source and Destination Increment.** The source and destination addresses can be controlled to increment, decrement, or not change, in order to give good flexibility for various types of transfers.

**Transfer mode.** The transfer mode determines whether the transfer should be a single transfer or a block transfer, or repeated versions of these.

**Byte or word transfers.** Determines whether each DMA transfer should be 8-bit (byte) or 16-bit (word).

**Interrupt Mask.** An interrupt request is generated upon completion of the DMA transfer. The interrupt mask bit controls if the interrupt generation is enabled or disabled.

**M8:** Decide whether to use seven or eight bits of length byte for transfer length. Only applicable when doing byte transfers.

A detailed description of the configuration parameters is given in the following sections.

### 13.2.2.1 Source Address

The address of the location in XDATA memory space where the DMA channel shall start to read data for the transfer.

### 13.2.2.2 Destination Address

The address of the location in XDATA memory space where the DMA channel shall start to write transfer data. The user must ensure that the destination is writable.

### 13.2.2.3 Transfer Count

The number of bytes/words needed to be transferred for the DMA transfer to be complete. When the transfer count is reached, the DMA controller rearms or disarms the DMA channel (depending on transfer mode) and alerts the CPU with an interrupt request. The transfer count can be defined in the configuration or it can be defined as a variable length described in the next section.

### 13.2.2.4 VLEN Setting

The DMA channel is capable of using the first byte or word (for word, bits 12:0 are used) in source data as the transfer length. This allows variable length transfers. When using variable length transfer, various options regarding how to count number of bytes to transfer is given. In any case, the LEN setting is used as maximum transfer count. Note that the M8 bit is only used when byte size transfers are chosen.

Options are:

1. *Default* : Transfer number of bytes/words commanded by first byte/word + 1 (transfers length byte/word, and then as many bytes/words as dictated by length byte/word)
2. Transfer number of bytes/words commanded by first byte/word
3. Transfer number of bytes/words commanded by first byte/word + 2 (transfers length byte/word, and then as many bytes/words as dictated by length byte/word + 1)
4. Transfer number of bytes/words commanded by first byte/word + 3 (transfers length byte/word, and then as many bytes/words as dictated by length byte/word + 2)

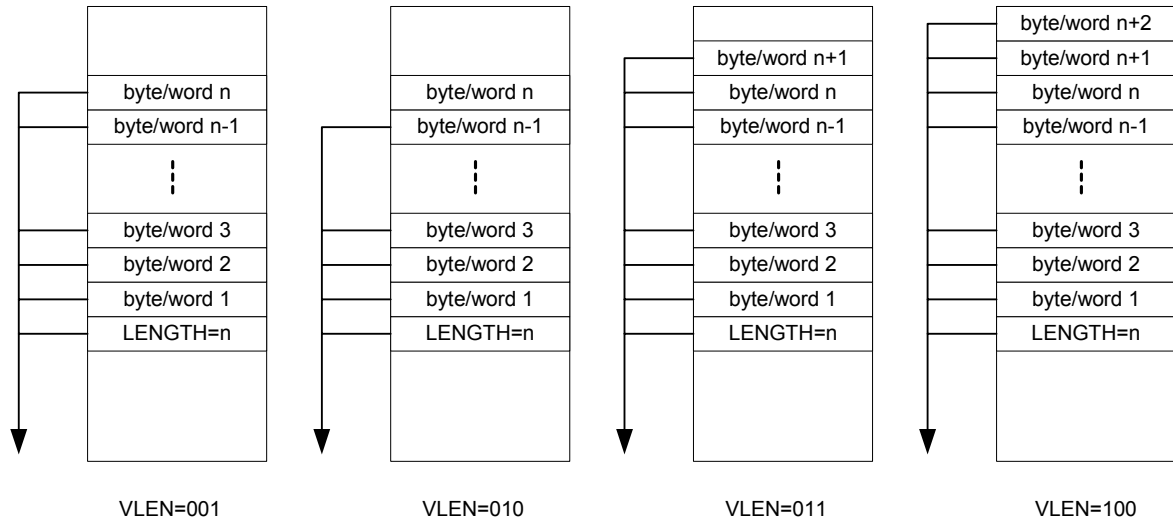

Figure 13: Variable Length (VLEN) Transfer Options

#### 13.2.2.5 Trigger Event

Each DMA channel can be set up to sense on a single trigger. This field determines which trigger the DMA channel shall sense. In addition to the configured trigger, a DMA channel can always be triggered by setting its designated `DMAREQ.DMAREQx` flag. The DMA trigger sources are described in Table 42 on page 90.

#### 13.2.2.6 Source and Destination Increment

When the DMA channel is armed or rearmed the source and destination addresses are transferred to internal address pointers. The possibilities for address increment are :

- *Increment by zero.* The address pointer shall remain fixed after each transfer.
- *Increment by one.* The address pointer shall increment one count after each transfer.
- *Increment by two.* The address pointer shall increment two counts after each transfer.
- *Decrement by one.* The address pointer shall decrement one count after each transfer.

#### 13.2.2.7 DMA Transfer Mode

The transfer mode determines how the DMA channel behaves when it starts transferring data. There are four transfer modes described below:

**Single.** On a trigger a single DMA transfer occurs and the DMA channel awaits the next trigger. After the number of transfers specified by the transfer count are completed, the CPU is notified and the DMA channel is disarmed.

**Block.** On a trigger the number of DMA transfers specified by the transfer count is performed as quickly as possible, after which the CPU is notified and the DMA channel is disarmed.

**Repeated single.** On a trigger a single DMA transfer occurs and the DMA channel awaits the next trigger. After the number of transfers specified by the transfer count are completed, the CPU is notified and the DMA channel is rearmed.

**Repeated block.** On a trigger the number of DMA transfers specified by the transfer count is performed as quickly as possible, after which the CPU is notified and the DMA channel is rearmed.

#### 13.2.2.8 DMA Priority

A DMA priority is associated with each DMA channel. The DMA priority is used to determine the winner in the case of multiple

simultaneous internal memory requests, and whether the DMA memory access should have priority or not over a simultaneous CPU memory access. In case of an internal tie, a round-robin scheme is used to ensure access for all. There are three levels of DMA priority:

**High.** Highest internal priority. DMA access will always prevail over CPU access.

**Normal.** Second highest internal priority. Guarantees that DMA access prevails over CPU on at least every second try.

**Low.** Lowest internal priority. DMA access will always defer to a CPU access.

### 13.2.2.9 Byte or Word transfers

Determines whether 8-bit (byte) or 16-bit (word) are done.

### 13.2.2.10 Interrupt mask

Upon completing a DMA transfer, the channel can generate an interrupt to the processor. This bit will mask the interrupt.

### 13.2.2.11 Mode 8 setting

This field determines whether to use seven or 8 bits of length byte for transfer length. Only applicable when doing byte transfers.

## 13.2.3 DMA Configuration Setup

The DMA channel parameters such as address mode, transfer mode and priority described in the previous section have to be configured before a DMA channel can be armed and activated. The parameters are not configured directly through SFR registers, but instead they are written in a special DMA configuration data structure in memory. Each DMA channel in use requires its own DMA configuration data structure. The DMA configuration data structure consists of eight bytes and is described in section 13.2.6 A DMA configuration data structure may reside at any location in XDATA decided upon by the user software, and the address location is

passed to the DMA controller through a set of SFRs `DMAxCFGH:DMAxCFGL`. Once a channel has been armed, the DMA controller will read the configuration data structure for that channel, given by the address in `DMAxCFGH:DMAxCFGL`.

It is important to note that the method for specifying the start address for the DMA configuration data structure differs between DMA channel 0 and DMA channels 1-4 as follows:

`DMA0CFGH:DMA0CFGL` gives the start address for DMA channel 0 configuration data structure.

`DMA1CFGH:DMA1CFGL` gives the start address for DMA channel 1 configuration data structure followed by channel 2-4 configuration data structures.

Thus the DMA controller expects the DMA configuration data structures for DMA channels 1-4 to lie in a contiguous area in memory, starting at the address held in `DMA1CFGH:DMA1CFGL` and consisting of 32 bytes.

## 13.2.4 Stopping DMA Transfers

Ongoing DMA transfer or armed DMA channels will be aborted using the `DMAARM` register to disarm the DMA channel.

One or more DMA channels are aborted by writing the following to the `DMAARM` register.

- Writing a 1 to `DMAARM.ABORT`, and at the same time,
- Select which DMA channels to abort by setting the corresponding, `DMAARM.DMAARMx` bits.

An example of DMA channel arm and disarm is shown in Figure 14.

```

MOV DMAARM, #0x03 ; arm DMA channel 0 and 1

MOV DMAARM, #0x81 ; disarm DMA channel 0,
                  ; channel 1 is still armed
  
```

**Figure 14: DMA arm/disarm example**



## 13.2.5 DMA Interrupts

Each DMA channel can be configured to generate an interrupt to the CPU upon completing a DMA transfer. This is accomplished with the IRQMASK bit in the channel configuration. The corresponding interrupt flag in the `DMAIRQ` SFR register will be set when the interrupt is generated.

Regardless of the IRQMASK bit in the channel configuration, the interrupt flag will be set upon DMA channel complete. Thus software should always check (and clear) this register when rearming a channel with a changed IRQMASK setting. Failure to do so could generate an interrupt based on the stored interrupt flag.

## 13.2.6 DMA Configuration Data Structure

For each DMA channel, the DMA configuration data structure consists of eight bytes. The configuration data structure is described in Table 43.

## 13.2.7 DMA USB Endianness (CC2511Fx)

When a USB FIFO is accessed using word transfer DMA the endianness of the word read/written can be controlled by setting the `ENDIAN.USBWLE` and `ENDIAN.USBRLE` configuration bits in the `ENDIAN` register. See section 13.15 for details.

DMA Trigger number	DMA Trigger name	Functional unit	Description
0	NONE	DMA	No trigger, setting DMAREQ . DMAREQx bit starts transfer
1	PREV	DMA	DMA channel is triggered by completion of previous channel
2	T1_CH0	Timer 1	Timer 1, compare, channel 0
3	T1_CH1	Timer 1	Timer 1, compare, channel 1
4	T1_CH2	Timer 1	Timer 1, compare, channel 2
5	-	-	Not in use.
6	T2_OVFL	Timer 2	Timer 2, overflow
7	T3_CH0	Timer 3	Timer 3, compare, channel 0
8	T3_CH1	Timer 3	Timer 3, compare, channel 1
9	T4_CH0	Timer 4	Timer 4, compare, channel 0
10	T4_CH1	Timer 4	Timer 4, compare, channel 1
11	ST	Sleep Timer	Sleep Timer compare
12	IOC_0	IO Controller	IO pin input transition
13	IOC_1	IO Controller	IO pin input transition
14	URX0	USART0	USART0 RX complete
15	UTX0	USART0	USART0 TX complete
16	URX1	USART1	USART1 RX complete
17	UTX1	USART1	USART1 TX complete
18	FLASH	Flash controller	Flash data write complete
19	RADIO	Radio	RF packet byte received/transmit
20	ADC_CHALL	ADC	ADC end of a conversion in a sequence, sample ready
21	ADC_CH0	ADC	ADC end of conversion channel 0 in sequence, sample ready
22	ADC_CH1	ADC	ADC end of conversion channel 1 in sequence, sample ready
23	ADC_CH2	ADC	ADC end of conversion channel 2 in sequence, sample ready
24	ADC_CH3	ADC	ADC end of conversion channel 3 in sequence, sample ready
25	ADC_CH4	ADC	ADC end of conversion channel 4 in sequence, sample ready
26	ADC_CH5	ADC	ADC end of conversion channel 5 in sequence, sample ready
27	ADC_CH6	ADC	ADC end of conversion channel 6 in sequence, sample ready
	I2SRX	I2S	I2S RX complete
28	ADC_CH7	ADC	ADC end of conversion channel 7 in sequence, sample ready
	I2STX	I2S	I2S TX complete
29	ENC_DW	AES	AES encryption processor requests download input data
30	ENC_UP	AES	AES encryption processor requests upload output data
31	-	-	Not in use.

Table 42: DMA Trigger Sources

Table 43: DMA Configuration Data Structure

Byte Offset	Bit	Field Name	Description
0	7:0	SRCADDR[15:8]	The DMA channel source address, high
1	7:0	SRCADDR[7:0]	The DMA channel source address, low
2	7:0	DESTADDR[15:8]	The DMA channel destination address, high. Note that flash memory is not directly writeable.
3	7:0	DESTADDR[7:0]	The DMA channel destination address, high. Note that flash memory is not directly writeable.
4	7:5	VLEN[2:0]	Variable length transfer mode. In word mode, bits 12:0 of the first word is considered as the transfer length.  000/111 Use LEN for transfer count  001 Transfer the number of bytes/words specified by first byte/word + 1 (up to a maximum specified by LEN). Thus transfer count excludes length byte/word  010 Transfer the number of bytes/words specified by first byte/word (up to a maximum specified by LEN). Thus transfer count includes length byte/word.  011 Transfer the number of bytes/words specified by first byte/word + 2 (up to a maximum specified by LEN).  100 Transfer the number of bytes/words specified by first byte/word + 3 (up to a maximum specified by LEN).  101 reserved  110 reserved
4	4:0	LEN[12:8]	The DMA channel transfer count.  Used as maximum allowable length when VLEN != 000/111. The DMA channel counts in words when in WORDSIZE mode, and otherwise in bytes.
5	7:0	LEN[7:0]	The DMA channel transfer count.  Used as maximum allowable length when VLEN != 000/111. The DMA channel counts in words when in WORDSIZE mode, and otherwise in bytes.
6	7	WORDSIZE	Selects whether each DMA transfer shall be 8-bit (0) or 16-bit (1).
6	6:5	TMODE[1:0]	The DMA channel transfer mode:  00 : Single 01 : Block 10 : Repeated single 11 : Repeated block
6	4:0	TRIG[4:0]	Select DMA trigger to use  00000 : No trigger (writing to DMAREQ is only trigger) 00001 : The previous DMA channel finished 00010 – 11111 : Selects one of the triggers shown in Table 42. The trigger is selected in the order shown in the table.
7	7:6	SRCINC[1:0]	Source address increment mode (after each transfer):  00 : 0 bytes/words 01 : 1 bytes/words 10 : 2 bytes/words 11 : -1 bytes/words
7	5:4	DESTINC[1:0]	Destination address increment mode (after each transfer):  00 : 0 bytes/words 01 : 1 bytes/words 10 : 2 bytes/words 11 : -1 bytes/words

Byte Offset	Bit	Field Name	Description
7	3	IRQMASK	Interrupt Mask for this channel. 0 : Disable interrupt generation 1 : Enable interrupt generation upon DMA channel done
7	2	M8	Mode of 8 <sup>th</sup> bit for VLEN transfer length; only applicable when WORDSIZE=0. 0 : Use all 8 bits for transfer count 1 : Use 7 LSB for transfer count
7	1:0	PRIORITY[1:0]	The DMA channel priority: 00 : Low, CPU has priority. 01 : Guaranteed, DMA at least every second try. 10 : High, DMA has priority 11 : Reserved.

## 13.2.8 DMA registers

This section describes the SFR registers associated with the DMA Controller

### DMAARM (0xD6) – DMA Channel Arm

Bit	Name	Reset	R/W	Description
7	ABORT	0	R0/W	DMA abort. This bit is used to stop ongoing DMA transfers. Writing a 1 to this bit will abort all channels which are selected by setting the corresponding DMAARM bit to 1 0 : Normal operation 1 : Abort channels all selected channels
6:5	–	00	R/W	Not used
4	DMAARM4	0	R/W	DMA arm channel 4 This bit must be set in order for any DMA transfers to occur on the channel. For non-repetitive transfer modes, the bit is automatically cleared upon completion.
3	DMAARM3	0	R/W	DMA arm channel 3 This bit must be set in order for any DMA transfers to occur on the channel. For non-repetitive transfer modes, the bit is automatically cleared upon completion.
2	DMAARM2	0	R/W	DMA arm channel 2 This bit must be set in order for any DMA transfers to occur on the channel. For non-repetitive transfer modes, the bit is automatically cleared upon completion.
1	DMAARM1	0	R/W	DMA arm channel 1 This bit must be set in order for any DMA transfers to occur on the channel. For non-repetitive transfer modes, the bit is automatically cleared upon completion.
0	DMAARM0	0	R/W	DMA arm channel 0 This bit must be set in order for any DMA transfers to occur on the channel. For non-repetitive transfer modes, the bit is automatically cleared upon completion.

**DMAREQ (0xD7) – DMA Channel Start Request and Status**

Bit	Name	Reset	R/W	Description
7:5	–	000	R0	Not used
4	DMAREQ4	0	R/W1 H0	DMA transfer request, channel 4 Manual trigger, set to 1 to start a transfer on the DMA channel (has the same effect as a single trigger event.). This bit is cleared when the DMA channel is granted access.
3	DMAREQ3	0	R/W1 H0	DMA transfer request, channel 3 Manual trigger, set to 1 to start a transfer on the DMA channel (has the same effect as a single trigger event.). This bit is cleared when the DMA channel is granted access.
2	DMAREQ2	0	R/W1 H0	DMA transfer request, channel 2 Manual trigger, set to 1 to start a transfer on the DMA channel (has the same effect as a single trigger event.). This bit is cleared when the DMA channel is granted access.
1	DMAREQ1	0	R/W1 H0	DMA transfer request, channel 1 Manual trigger, set to 1 to start a transfer on the DMA channel (has the same effect as a single trigger event.). This bit is cleared when the DMA channel is granted access.
0	DMAREQ0	0	R/W1 H0	DMA transfer request, channel 0 Manual trigger, set to 1 to start a transfer on the DMA channel (has the same effect as a single trigger event.). This bit is cleared when the DMA channel is granted access.

**DMA0CFGH (0xD5) – DMA Channel 0 Configuration Address High Byte**

Bit	Name	Reset	R/W	Description
7:0	DMA0CFG[15:8]	0x00	R/W	The DMA channel 0 configuration address, high order

**DMA0CFGH (0xD4) – DMA Channel 0 Configuration Address Low Byte**

Bit	Name	Reset	R/W	Description
7:0	DMA0CFG[7:0]	0x00	R/W	The DMA channel 0 configuration address, low order

**DMA1CFGH (0xD3) – DMA Channel 1-4 Configuration Address High Byte**

Bit	Name	Reset	R/W	Description
7:0	DMA1CFG[15:8]	0x00	R/W	The DMA channel 1-4 configuration address, high order

**DMA1CFGL (0xD2) – DMA Channel 1-4 Configuration Address Low Byte**

Bit	Name	Reset	R/W	Description
7:0	DMA1CFG[7:0]	0x00	R/W	The DMA channel 1-4 configuration address, low order

**DMAIRQ (0xD1) – DMA Interrupt Flag**

Bit	Name	Reset	R/W	Description
7:5	–	000	R/W0	Not used
4	DMAIF4	0	R/W0	DMA channel 4 interrupt flag. 0 : DMA channel transfer not complete 1 : DMA channel transfer complete/interrupt pending
3	DMAIF3	0	R/W0	DMA channel 3 interrupt flag. 0 : DMA channel transfer not complete 1 : DMA channel transfer complete/interrupt pending
2	DMAIF2	0	R/W0	DMA channel 2 interrupt flag. 0 : DMA channel transfer not complete 1 : DMA channel transfer complete/interrupt pending
1	DMAIF1	0	R/W0	DMA channel 1 interrupt flag. 0 : DMA channel transfer not complete 1 : DMA channel transfer complete/interrupt pending
0	DMAIF0	0	R/W0	DMA channel 0 interrupt flag. 0 : DMA channel transfer not complete 1 : DMA channel transfer complete/interrupt pending

## ENDIAN (0x95) – USB Endianness Control (CC2511Fx)

Bit	Name	Reset	R/W	Description
7:2	–	0	R0	Not used. Always 000000.
1	USBWLE	0	R/W	USB Write Endianness setting for DMA channel word transfers to USB. 0 Big Endian 1 Little Endian
0	USBRLLE	0	R/W	USB Read Endianness setting for DMA channel word transfers from USB. 0 Big Endian 1 Little Endian



## 13.3 16-bit Timer, Timer 1

Timer 1 is an independent 16-bit timer which supports typical timer/counter functions such as input capture, output compare and PWM functions. The timer has three independent capture/compare channels. The timer uses one I/O pin per channel. The timer is used for a wide range of control and measurement applications and the availability of up/down count mode with three channels will for example allow implementation of motor control applications.

The features of Timer 1 are as follows:

- Three capture/compare channels
- Rising, falling, or any edge input capture
- Set, clear or toggle output compare
- Free-running, modulo or up/down counter operation
- Clock prescaler for divide by 1, 8, 32 or 128
- Interrupt request generated on each capture/compare and terminal count
- Capture triggered by radio
- DMA trigger function
- Delta-Sigma Modulator (DSM) mode

### 13.3.1 16-bit Timer Counter

The timer consists of a 16-bit counter that increments or decrements at each active clock edge. The period of the active clock edges is defined by the register bits `CLKCON.TICKSPD` which sets the global division of the system clock giving a variable clock tick frequency from 0.203 MHz to 26 MHz for **CC2510Fx** and 0.1875 MHz to 24 MHz for **CC2511Fx**. This is further divided in Timer 1 by the prescaler value set by `T1CTL.DIV`. This prescaler value can be from 1 to 128. Thus the lowest clock frequency used by Timer 1 is 1586.9 Hz and the highest is 26 MHz when the 26 MHz crystal oscillator is used as system clock source (**CC2510Fx**). The lowest clock frequency used by Timer 1 is 1464.8 Hz and the highest

is 24 MHz for **CC2511Fx**. When the 13 MHz RC oscillator is used as system clock source, then the highest clock frequency used by Timer 1 is 13 MHz.

The counter operates as either a free-running counter, a modulo counter or as an up/down counter for use in centre-aligned PWM.

It is possible to read the 16-bit counter value through the two 8-bit SFRs; `T1CNTH` and `T1CNTL`, containing the high-order byte and low-order byte respectively. When the `T1CNTL` is read, the high-order byte of the counter at that instant is buffered in `T1CNTH` so that the high-order byte can be read from `T1CNTH`. Thus `T1CNTL` shall always be read first before reading `T1CNTH`.

All write accesses to the `T1CNTL` register will reset the 16-bit counter.

The counter produces an interrupt request when the terminal count value (overflow) is reached. It is possible to clear and halt the counter with `T1CTL` control register settings. The counter is started when a value other than 00 is written to `T1CTL.MODE`. If 00 is written to `T1CTL.MODE` the counter halts at its present value.

### 13.3.2 Timer 1 Operation

In general, the control register `T1CTL` is used to control the timer operation. The various modes of operation are described below.

### 13.3.3 Free-running Mode

In the free-running mode of operation the counter starts from 0x0000 and increments at each active clock edge. When the counter reaches 0xFFFF the counter is loaded with 0x0000 and continues incrementing its value as shown in Figure 15. When the terminal count value 0xFFFF is reached, the flag `T1CTL.OVFIF` is set. An interrupt request is generated if the corresponding interrupt mask bit `TIMIF.OVFIM` is set. The free-running mode can be used to generate independent time intervals and output signal frequencies.

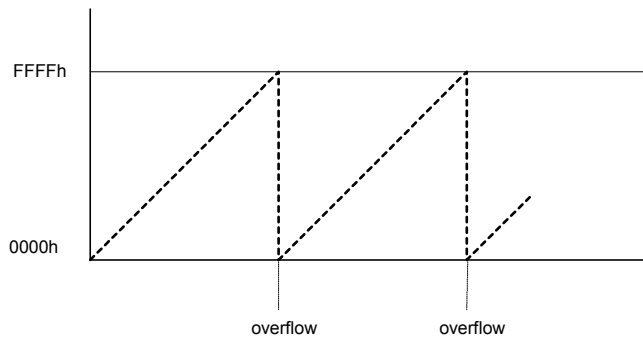

Figure 15: Free-running mode

### 13.3.4 Modulo Mode

When the timer operates in modulo mode the 16-bit counter starts at 0x0000 and increments at each active clock edge. When the counter reaches the terminal count value held in registers T1CC0H:T1CC0L, the counter is reset to 0x0000 and continues to increment. The flag T1CTL.OVFIF is set when the

terminal count value (overflow) is reached. An interrupt request is generated if the corresponding interrupt mask bit TIMIF.OVFIM is set. The modulo mode can be used for applications where a count value other than 0xFFFF is required. The counter operation is shown in Figure 16.

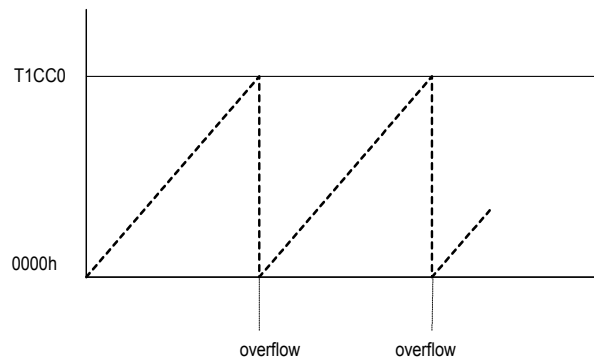

Figure 16: Modulo mode

### 13.3.5 Up/down Mode

In the up/down timer mode, the counter repeatedly starts from 0x0000 and counts up until the value held in T1CC0H:T1CC0L is reached and then the counter counts down until 0x0000 is reached as shown in Figure 17. This timer mode is used when symmetrical output pulses are required with a period other

than 0xFFFF, and therefore allows implementation of centre-aligned PWM output applications. The flag T1CTL.OVFIF is set when the timer turns around at 0x0000.

The counter is reset to 0x000 by writing any value to T1CNTL.

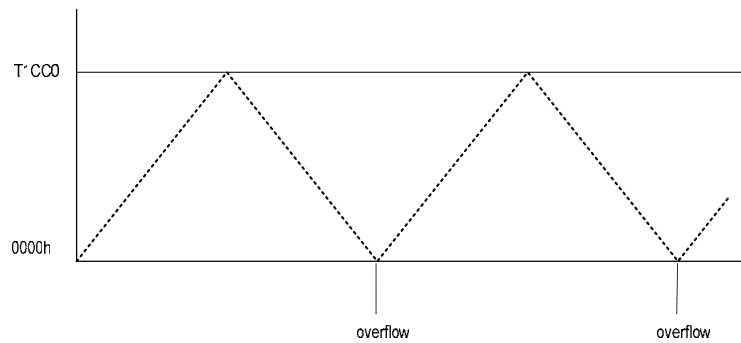

Figure 17 : Up/down mode

### 13.3.6 Channel Mode Control

The channel mode is set with each channel's control and status register `T1CCTLn`. The settings include input capture and output compare modes.

### 13.3.7 Input Capture Mode

When a channel is configured as an input capture channel, the I/O pin associated with that channel, is configured as an input. After the timer has been started, a rising edge, falling edge or any edge on the input pin will trigger a capture of the 16-bit counter contents into the associated capture register. Thus the timer is able to capture the time when an external event takes place.

*Note: before an I/O pin can be used by the timer, the required I/O pin must be configured as a Timer 1 peripheral pin as described in section 13.1.4 on page 67 .*

The channel input pin is synchronized to the internal system clock. Thus pulses on the input pin must have a minimum duration greater than the system clock period.

The content of the 16-bit capture register is read out from registers `T1CCnH:T1CCnL`.

When the capture takes place the interrupt flag for the channel is set. This bit is `T1CTL.CH0IF` for channel 0, `T1CTL.CH1IF` for channel 1, and `T1CTL.CH2IF` for channel 2. An interrupt request is generated if the corresponding interrupt mask bit on `T1CCTL0.IM`, `T1CCTL1.IM`, or `T1CCTL2.IM`, respectively, is set.

#### 13.3.7.1 RF Event Capture

Each timer channel may be configured so that an RF interrupt RFIF event will trigger a capture instead of the normal input pin

capture. This function is selected with the register bit `T1CCTLx.CPSEL` which selects to use either the input pin or the RFIF interrupt as capture event. When RFIF is selected as capture input, the interrupt source(s) enabled by `RFIM` (see section 15.3.1 on page 193) will trigger a capture. In this way the timer can be used to capture a value when e.g. a start of frame delimiter (SFD) is detected.

### 13.3.8 Output Compare Mode

In output compare mode the I/O pin associated with a channel is set as an output. After the timer has been started, the contents of the counter is compared with the contents of the channel compare register `T1CCnH:T1CCnL`. If the compare register equals the counter contents, the output pin is set, reset or toggled according to the compare output mode setting of `T1CCTLn.CMP`. Note that all edges on output pins are glitch-free when operating in a given output compare mode. Writing to the compare register `T1CCnL` is buffered so that a value written to `T1CCnL` does not take effect until the corresponding high order register, `T1CCnH` is written. For output compare modes 1-3, a new value written to the compare register `T1CCnH:T1CCnL` takes effect after the registers have been written. For other output compare modes the new value written to the compare register take effect when the timer reaches 0x0000.

Note that channel 0 has fewer output compare modes than channel 1 and 2 because `T1CC0H:T1CC0L` has a special function in modes 6 and 7, meaning these modes would not be useful for channel 0.

When a compare occurs, the interrupt flag for the channel is set. This bit is `T1CTL.CH0IF` for channel 0, `T1CTL.CH1IF` for channel 1, and `T1CTL.CH2IF` for channel 2. An interrupt request is generated if the corresponding

interrupt mask bit on `T1CCTL0.IM`, `T1CCTL1.IM`, or `T1CCTL2.IM`, respectively, is set.

Examples of output compare modes in various timer modes are given in the following figures.

**Edge-aligned** PWM output signals can be generated using the timer modulo mode and channels 1 and 2 in output compare mode 5 or 6 as shown in Figure 19. The period of the PWM signal is determined by the setting `T1CC0` and the duty cycle for the channel output is determined by `T1CCn`. The timer free-running mode may also be used. In this case `CLKCON.TICKSPD` and the prescaler divider value `T1CTL.DIV` set the period of the PWM signal. The polarity of the PWM signal is determined by whether output compare mode 5 or 6 is used. PWM output signals can also be generated using output compare modes 3 and 4 as shown in the same figure, or by using modulo mode as shown in Figure 19. Using output compare mode 3 and 4 is preferred for simple PWM.

**Centre-aligned** PWM outputs can be generated when the timer up/down mode is selected. The channel output compare mode 3

or 4 is selected depending on required polarity of the PWM signal. The period of the PWM signal is determined by `T1CC0` and the duty cycle for the channel output is determined by `T1CCn`.

In some types of applications, a defined delay or dead time is required between outputs. Typically this is required for outputs driving an H-bridge configuration to avoid uncontrolled cross-conduction in one side of the H-bridge. The delay or dead-time can be obtained in the PWM outputs by using `T1CCn` as shown in the following:

Assuming that channel 1 and channel 2 are used to drive the outputs using timer up/down mode and the channels use output compare modes 3 and 4 respectively. If `T1CC1` is greater than `T1CC2`, then the timer period (in Timer 1 clock periods) is:

$$T_P = T1CC0 \times 2$$

and the dead time, i.e. the time from when the channel 1 output goes low until the channel 2 output goes high, (in Timer 1 clock periods) is given by:

$$T_D = T1CC1 - T1CC2$$

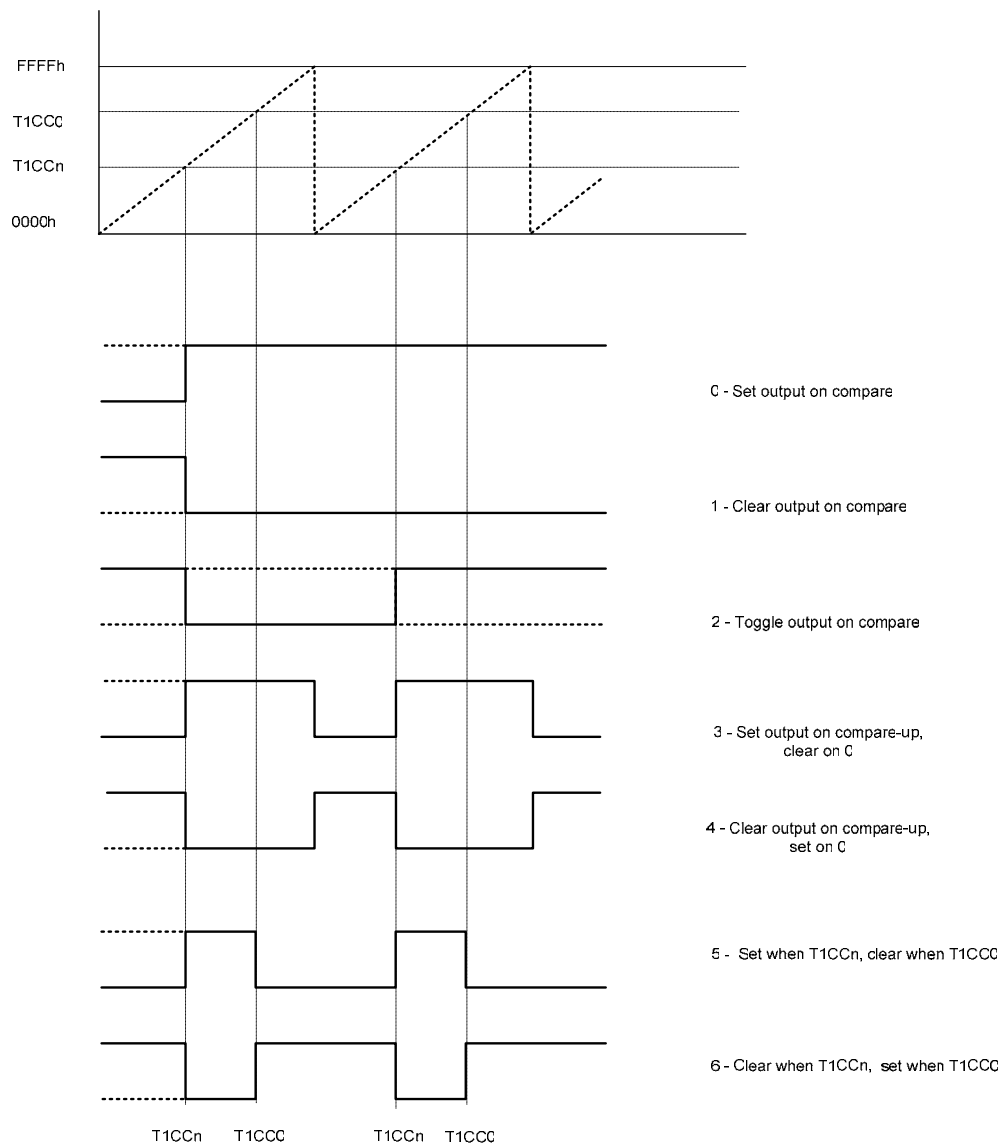

Figure 18: Output compare modes, timer free-running mode

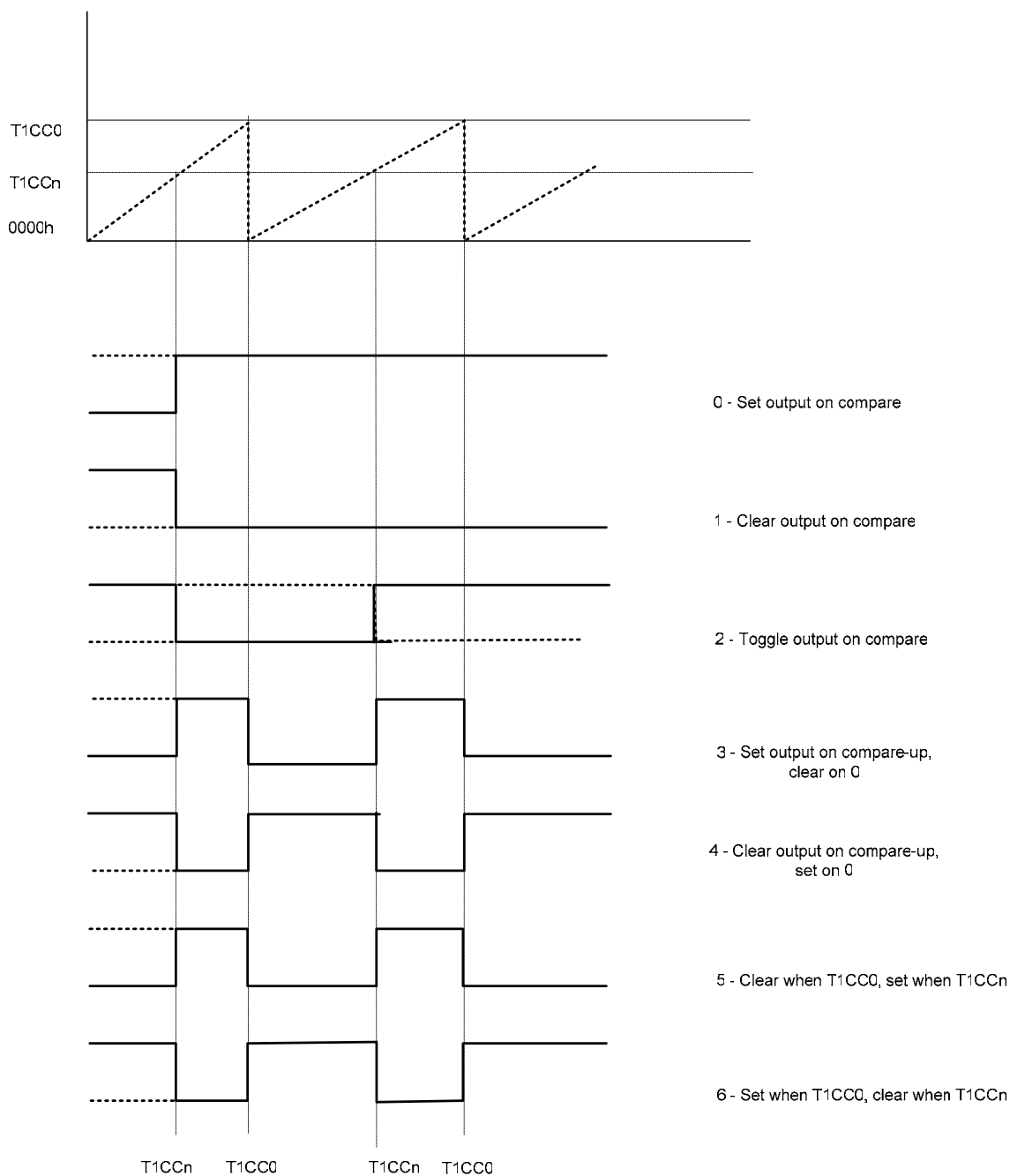

Figure 19: Output compare modes, timer modulo mode

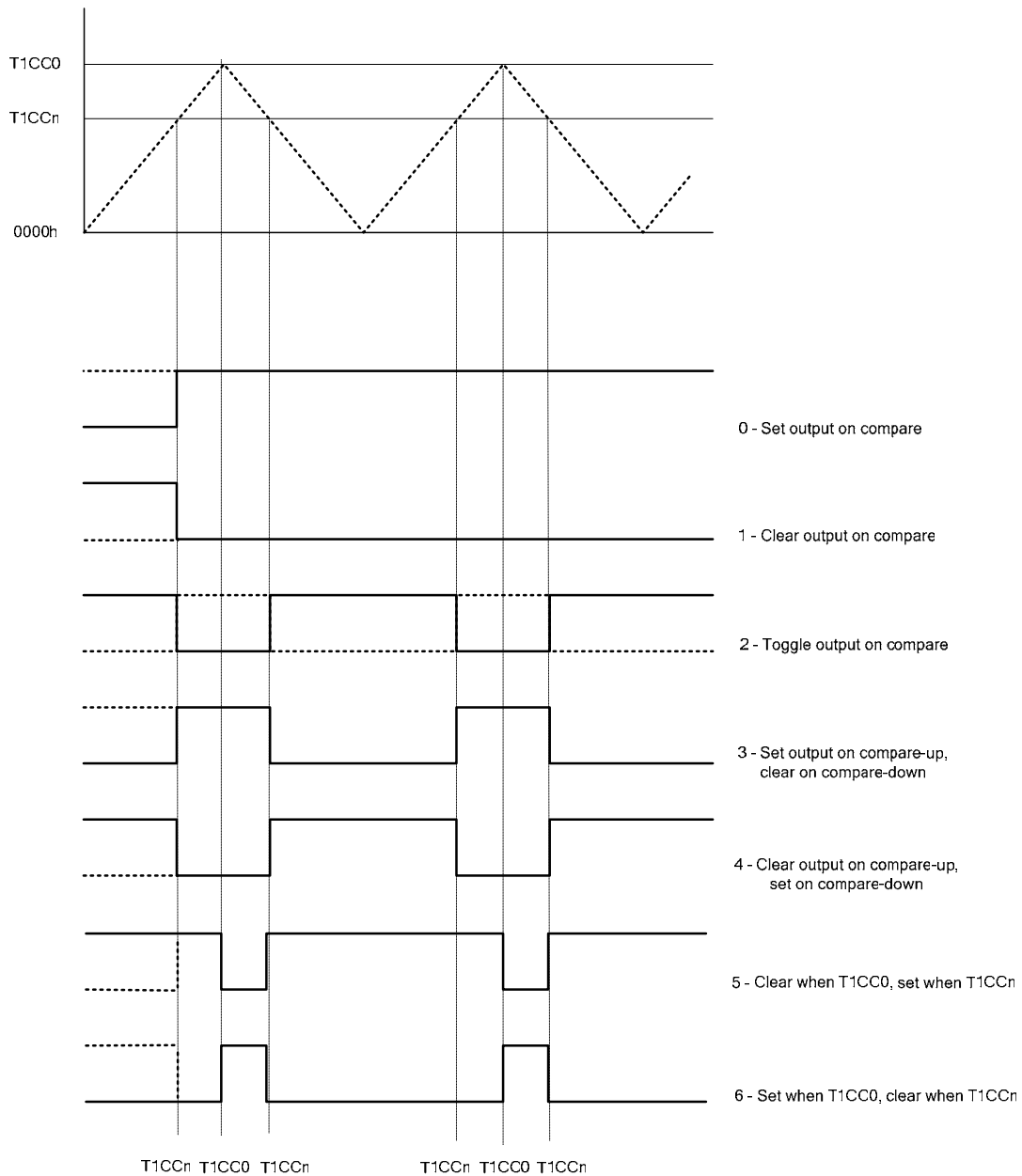

Figure 20: Output modes, timer up/down mode

### 13.3.9 Timer 1 Interrupts

There is one interrupt vector assigned to the timer. An interrupt request is generated when one of the following timer events occur:

- Counter reaches terminal count value or turns around on zero
- Input capture event.
- Output compare event

The register bits T1CTL.OVFIF, T1CTL.CH0IF, T1CTL.CH1IF, and T1CTL.CH2IF contains the interrupt flags for the terminal count value event, and the three channel compare/capture events, respectively. An interrupt request is only generated when the corresponding interrupt mask bit is set. The interrupt mask bits are T1CCTL0.IM, T1CCTL1.IM, T1CCTL2.IM and

TIMIF.OVFIF. If there are other pending interrupts, the corresponding interrupt flag must be cleared by software before a new interrupt request is generated. Also, enabling an interrupt mask bit will generate a new interrupt request if the corresponding interrupt flag is set.

When the timer is used in Free-running Mode or Modulo Mode the interrupt flags are set as follows:

- T1CTL.CH0IF, T1CTL.CH1IF and T1CTL.CH2IF are set on compare/capture event
- T1CTL.OVFIF is set when counter reaches terminal count value

When the timer is used in Up/Down Mode the interrupt flags are set as follows:

In compare mode:

- T1CTL.CH0IF and T1CTL.OVFIF are set when counter turns around on zero
- T1CTL.CH1IF and T1CTL.CH2IF are set on compare event

In capture mode:

- T1CTL.CH0IF, T1CTL.CH1IF and T1CTL.CH2IF are set on capture event
- T1CTL.OVFIF is set when counter turns around on zero

### 13.3.10 Timer 1 DMA Triggers

There are three DMA triggers associated with Timer 1, one for each channel. These are DMA triggers T1\_CH0, T1\_CH1 and T1\_CH2 which are generated when the corresponding interrupt flags are set:

- T1\_CH0 is generated when T1CTL.CH0IF is set
- T1\_CH1 is generated when T1CTL.CH1IF is set
- T1\_CH2 is generated when T1CTL.CH2IF is set

See Table 42 for a list of all DMA triggers.

### 13.3.11 DSM Mode

Timer 1 also contains a 1-bit Delta Sigma Modulator (DSM) of second order that can be used to produce a high quality mono audio output PWM signal. The DSM removes the need for high order external filtering required when using regular PWM mode.

The DSM operates at a fixed speed of either 1/4 or 1/8 of the Timer 1 update speed (CLKCON.TICKSPD) while input samples are updated at a configurable sampling rate set by Timer 1 channel 0.

An interpolator is used to match the sampling rate with the DSM update rate. This interpolator is of first order with a scaling compensation. The scaling compensation is due to variable gain defined by the difference in sampling speed and DSM speed. This interpolation mechanism can be disabled, thus using a zeroth interpolator.

In addition to the interpolator, a shaper can be used to account for differences in rise/fall times in the output signal. This shaper ensures a rising and a falling edge per bit and will thus limit the output swing to the range 1/8 to 7/8 of I/O VDD when the DSM operates at 1/8 of the Timer 1 update speed or 1/4 to 3/4 of I/O VDD when the DSM operates at 1/4 of the Timer 1 update speed.

The DSM is used as in PWM mode where channel 0 defines the period/sampling rate. The DSM can not use the Timer 1 prescaler to further slow down the period. CLKCON.TICKSPD, however, can be used.

Timer 1 channel 0 must be configured to compare modulo mode and have a terminal count value that matches the incoming sample rate. Table 44 shows some Timer 1 channel 0 periode settings (T1CC0 register) for different Timer 1 clock speeds and data rates (note that tick speed is not used, i.e. CLKCON.TICKSPD = 000).



Data rate	T1CC0H	T1CC0L
8 kHz @ 24 MHz	0x0B	0xB7
8 kHz @ 26 MHz	0x0C	0xB1
16 kHz @ 24 MHz	0x05	0xDB
16 kHz @ 26 MHz	0x06	0x59
48 kHz @ 24 MHz	0x01	0xF3
48 kHz @ 26 MHz	0x02	0x1D
64 kHz @ 24 MHz	0x01	0x76
64 kHz @ 26 MHz	0x01	0x96

**Table 44 Channel 0 period setting for some sampling rates (CLKCON.TICKSPD = 000)**

The DSM starts immediately after DSM mode has been enabled by setting the T1CCTL1.CMP field. Thus, all configuration should have been performed prior to enabling DSM mode. Also, the Timer 1 counter should be cleared and started just before starting the DSM operation. A simple procedure for setting up DSM mode should then be as follows:

1. Suspend timer 1 (T1CTL.MODE = 0)
2. Clear timer counter by writing any value to T1CNTL, (T1CNT = 0x0000)
3. Set the sample rate by writing the Timer 1 channel 0 count period, T1CC0.
4. Set Timer 1 channel 0 compare mode (T1CCTL0.MODE = 1)
5. Load first sample if available (or zero if no sample available) into T1CC1H:T1CC1L.
6. Set timer operation to modulo mode (T1CTL.MODE = 2)
7. Configure the DSM by setting the MODE and CAP fields of the T1CCTL1 register.
8. Enable DSM mode (T1CCTL1.CMP = 7)

On each Timer 1 IRQ or Timer 1 DMA trigger, write a new sample to the T1CC1H:T1CC1L registers. The least significant bits must be written to T1CC1L before the most significant bits are written to T1CC1H.

The samples written must be signed 2's complement values. The 2 least significant bits will always be treated as 0, thus the effective sample size is 14 bits.

### 13.3.12 Timer 1 Registers

This section describes the Timer 1 registers that consist of the following registers:

- T1CNTH – Timer 1 Count High
- T1CNTL – Timer 1 Count Low
- T1CTL – Timer 1 Control and Status
- T1CCTLx – Timer 1 Channel x Capture/Compare Control
- T1CCxH – Timer 1 Channel x Capture/Compare Value High
- T1CCxL – Timer 1 Channel x Capture/Compare Value Low

**T1CNTH (0xE3) – Timer 1 Counter High**

Bit	Name	Reset	R/W	Description
7:0	CNT[15:8]	0x00	R	Timer count high order byte. Contains the high byte of the 16-bit timer counter buffered at the time T1CNTL is read.

**T1CNTL (0xE2) – Timer 1 Counter Low**

Bit	Name	Reset	R/W	Description
7:0	CNT[7:0]	0x00	R/W	Timer count low order byte. Contains the low byte of the 16-bit timer counter. Writing anything to this register results in the counter being cleared to 0x0000.

**T1CTL (0xE4) – Timer 1 Control and Status**

Bit	Name	Reset	R/W	Description
7	CH2IF	0	R/W0	Timer 1 channel 2 interrupt flag. Set when the channel 2 interrupt condition occurs. Writing a 1 has no effect.
6	CH1IF	0	R/W0	Timer 1 channel 1 interrupt flag. Set when the channel 1 interrupt condition occurs. Writing a 1 has no effect.
5	CH0IF	0	R/W0	Timer 1 channel 0 interrupt flag. Set when the channel 0 interrupt condition occurs. Writing a 1 has no effect.
4	OVFIF	0	R/W0	Timer 1 counter overflow interrupt flag. Set when the counter reaches the terminal count value in free-running or modulo mode. Writing a 1 has no effect.
3:2	DIV[1:0]	00	R/W	Prescaler divider value. Generates the active clock edge used to update the counter as follows: 00 Tick frequency/1 01 Tick frequency/8 10 Tick frequency/32 11 Tick frequency/128
1:0	MODE[1:0]	00	R/W	Timer 1 mode select. The timer operating mode is selected as follows: 00 Operation is suspended 01 Free-running, repeatedly count from 0x0000 to 0xFFFF 10 Modulo, repeatedly count from 0x0000 to T1CC0 11 Up/down, repeatedly count from 0x0000 to T1CC0 and from T1CC0 down to 0x0000

**T1CCTL0 (0xE5) – Timer 1 Channel 0 Capture/Compare Control**

Bit	Name	Reset	R/W	Description
7	CPSEL	0	R/W	Capture select. Timer 1 channel 0 captures on RFIF interrupt from RF transceiver or capture input pin. 0 Use normal capture input 1 Use RFIF interrupt from RF transceiver for capture
6	IM	1	R/W	Channel 0 interrupt mask. Enables interrupt request when set.
5:3	CMP[2:0]	000	R/W	Channel 0 compare mode select. Selects action on output when timer value equals compare value in T1CC0 000 Set output on compare 001 Clear output on compare 010 Toggle output on compare 011 Set output on compare-up, clear on 0 (clear on compare-down in up/down mode) 100 Clear output on compare-up, set on 0 (set on compare-down in up/down mode) 101 Not used 110 Not used 111 Not used
2	MODE	0	R/W	Mode. Select Timer 1 channel 0 capture or compare mode 0 Capture mode 1 Compare mode
1:0	CAP[1:0]	00	R/W	Channel 0 capture mode select 00 No capture 01 Capture on rising edge 10 Capture on falling edge 11 Capture on both edges

**T1CC0H (0xDB) – Timer 1 Channel 0 Capture/Compare Value High**

Bit	Name	Reset	R/W	Description
7:0	T1CC0[15:8]	0x00	R/W	Timer 1 channel 0 capture/compare value, high order byte

**T1CC0L (0xDA) – Timer 1 Channel 0 Capture/Compare Value Low**

Bit	Name	Reset	R/W	Description
7:0	T1CC0[7:0]	0x00	R/W	Timer 1 channel 0 capture/compare value, low order byte

**T1CCTL1 (0xE6) – Timer 1 Channel 1 Capture/Compare Control**

Bit	Name	Reset	R/W	Description
7	CPSEL	0	R/W	Capture select. Timer 1 channel 1 captures on RFIF interrupt from RF transceiver or capture input pin 0 Use normal capture input 1 Use RFIF interrupt from RF transceiver for capture
6	IM	1	R/W	Channel 1 interrupt mask. Enables interrupt request when set.
5:3	CMP[2:0]	000	R/W	Channel 1 compare mode select. Selects action on output when timer value equals compare value in T1CC1 000 Set output on compare 001 Clear output on compare 010 Toggle output on compare 011 Set output on compare-up, clear on 0 (clear on compare-down in up/down mode) 100 Clear output on compare-up, set on 0 (set on compare-down in up/down mode) 101 Clear when equal T1CC0, set when equal T1CC1 110 Set when equal T1CC0, clear when equal T1CC1 111 DSM mode enable
2	MODE	0	R/W	Mode. Select Timer 1 channel 1 capture or compare mode. (timer mode) / Select DSM update speed (DSM mode) 0 Capture mode / DSM at timer/8 update speed 1 Compare mode / DSM at timer/4 update speed
1:0	CAP[1:0]	00	R/W	Channel 1 capture mode select (timer mode) / DSM interpolator and output shaping configuration (DSM mode) 00 No capture / DSM interpolator and output shaping enabled 01 Capture on rising edge / DSM interpolator enabled and output shaping disabled 10 Capture on falling edge / DSM interpolator disabled and output shaping enabled 11 Capture on all edges / DSM interpolator and output shaping disabled

**T1CC1H (0xDD) – Timer 1 Channel 1 Capture/Compare Value High**

Bit	Name	Reset	R/W	Description
7:0	T1CC1[15:8]	0x00	R/W	Timer 1 channel 1 capture/compare value, high order byte (timer mode) DSM data high order byte (DSM mode)

## T1CC1L (0xDC) – Timer 1 Channel 1 Capture/Compare Value Low

Bit	Name	Reset	R/W	Description
7:0	T1CC1[7:0]	0x00	R/W	Timer 1 channel 1 capture/compare value, low order byte (timer mode)  DSM data low order byte. The two least significant bits are not used. (DSM mode)

## T1CCTL2 (0xE7) – Timer 1 Channel 2 Capture/Compare Control

Bit	Name	Reset	R/W	Description
7	CPSEL	0	R/W	Capture select. Timer 1 channel 2 captures on RFIF from RF transceiver or capture input pin  0     Use normal capture input 1     Use RFIF from RF transceiver for capture
6	IM	1	R/W	Channel 2 interrupt mask. Enables interrupt request when set.
5:3	CMP[2:0]	000	R/W	Channel 2 compare mode select. Selects action on output when timer value equals compare value in T1CC2  000    Set output on compare 001    Clear output on compare 010    Toggle output on compare 011    Set output on compare-up, clear on 0 (clear on compare-down in up/down mode) 100    Clear output on compare-up, set on 0 (set on compare-down in up/down mode) 101    Clear when equal T1CC0, set when equal T1CC2 110    Set when equal T1CC0, clear when equal T1CC2 111    Not used
2	MODE	0	R/W	Mode. Select Timer 1 channel 2 capture or compare mode  0     Capture mode 1     Compare mode
1:0	CAP[1:0]	00	R/W	Channel 2 capture mode select  00    No capture 01    Capture on rising edge 10    Capture on falling edge 11    Capture on all edges

## T1CC2H (0xDF) – Timer 1 Channel 2 Capture/Compare Value High

Bit	Name	Reset	R/W	Description
7:0	T1CC2[15:8]	0x00	R/W	Timer 1 channel 2 capture/compare value, high order byte

**T1CC2L (0xDE) – Timer 1 Channel 2 Capture/Compare Value Low**

Bit	Name	Reset	R/W	Description
7:0	T1CC2[7:0]	0x00	R/W	Timer 1 channel 2 capture/compare value, low order byte

The `TIMIF.OVFIM` register bit resides in the `TIMIF` register, which is described together with timer 3 and timer 4

### 13.4 MAC Timer (Timer 2)

The MAC timer is designed for slot timing operations for MAC layers of RF protocols. The timer includes a highly tunable prescaler allowing the user to select a timer tick interval that equals, or is an integer fraction of a transmission slot.

- 8-bit timer
- 18-bit tunable prescaler

#### 13.4.1 Timer Operation

This section describes the operation of the timer.

The timer count can be read from the T2CT SFR register. The timer decrements by 1 at each timer tick. When the timer count reaches 0x00 the timer expires and does not wrap around. When the timer expires, the register bit T2CTL.TEX is set to 1. An interrupt request is generated when the timer expires, if the interrupt mask T2CTL.INT is 1.

When a new value is written to the timer count register, T2CT, then this value is stored in the counter immediately. If a tick and a write to T2CT occurs at the same time, the written value will be decremented before it is stored.

The timer tick period T, is given as:

$$T = T2PR * Val(T2CTL.TIP) \text{ clock cycles.}$$

where the function Val(x) is set by the tick period, T2CTL.TIP and defined as

$$Val(00)=64$$

$$Val(01)=128$$

$$Val(10)=256$$

$$Val(11)=1024$$

The tick generator can be set to run freely or to run only when the timer holds a non-zero value. Whenever the tick generator is started it starts from its zero state. At this point there will be  $T2PR * Val(T2CTL.TIP) - 1$  clock cycles until the next tick.

#### 13.4.2 Timer 2 Registers

The SFR registers associated with Timer 2 are listed in this section. These registers are the following:

- T2CTL – Timer 2 Control
- T2PRE – Timer 2 Prescaler
- T2CT – Timer 2 Count

## T2CTL (0x9E) – Timer 2 Control

Bit	Name	Reset	R/W	Description
7	–	0	R/W0	Not used.
6	TEX	0	R/W0	Timer expired. This bit is set when the timer expires. Writing a 1 to this bit has no effect
5	–	0	R/W	Reserved. Should always be written as 0
4	INT	0	R/W	Interrupt enable. Select interrupt generated on timer expiration 0 Interrupt disabled 1 Interrupt enabled
3	–	0	R/W	Reserved. Should always be written as 0
2	TIG	0	R/W	Tick generator mode. 0 Tick generator is running when T2CT not equal to 00h. The tick generator will always start running from its null state. 1 Tick generator is in free-running mode. If it is not already running it will start from its null state when a '1' is written to TIG.
1:0	TIP[1:0]	00	R/W	Tick period. Selects tick period based on prescaler multiplier value. 00 Tick period is T2PR * 64 clock cycles 01 Tick period is T2PR * 128 clock cycles 10 Tick period is T2PR * 256 clock cycles 11 Tick period is T2PR * 1024 clock cycles

## T2CT (0x9C) – Timer 2 Count

Bit	Name	Reset	R/W	Description
7:0	CNT[7:0]	0x00	R/W	Timer count. Contents of 8-bit counter

## T2PR (0x9D) – Timer 2 Prescaler

Bit	Name	Reset	R/W	Description
7:0	PR[7:0]	0x00	R/W	Timer prescaler multiplier. 0x00 is interpreted as 256



### 13.5 Sleep Timer

The Sleep Timer is used to control when the *CC2510Fx/CC2511Fx* exits from the low-power modes PM1 or PM2. Thus the Sleep Timer can be used to implement a wake up functionality which enables *CC2510Fx/CC2511Fx* to periodically wake up from low-power mode and listen for incoming RF packets. Additionally the Sleep Timer can be used as a real time clock when the 32.768 kHz crystal oscillator is used.

#### 13.5.1 Sleep Timer Operation

This section describes the operation of the timer.

The Sleep Timer consists of a 31-bit counter. The appropriate bits of this counter are selected according to a resolution setting determined by the `WORCTL.WOR_RES` register bits. The Sleep Timer is either clocked by the 32.768 kHz crystal oscillator or the 34.6667 kHz (26MHz / 750) low power RC oscillator. The timer runs in all power modes except PM3 where all oscillators are powered off. The timer can be reset by writing 1 to the `WORCTL.WOR_RESET` register bit.

The Sleep Timer has a programmable timing event called Event 0. While in power mode PM1 or PM2, reaching Event 0 will turn on the digital voltage regulator and start the crystal oscillator.

The time between two consecutive Event 0's is programmed with timeout value set by a mantissa value given by `WOREVT1.EVENT0` and `WOREVT0.EVENT0`, and an exponent value set by `WORCTRL.WOR_RES`. The equation is:

$$t_{Event0} = \frac{750}{f_{XOSC}} \cdot EVENT0 \cdot 2^{5-WOR\_RES}$$

#### 13.5.2 Low power RC oscillator and timing

This section applies to using the low power RC oscillator as clock source for the Sleep Timer.

The frequency of the low-power RC oscillator, which can be used as clock source for the Sleep Timer, varies with temperature and supply voltage. In order to keep the frequency as accurate as possible, the RC oscillator will be calibrated whenever possible, which is when the 26/48 MHz crystal oscillator is running and the chip is in the PM0 power mode. When the chip goes to PM1 or PM2, the RC oscillator will use the last valid calibration result. The frequency of the low power RC oscillator is therefore locked to the 26/48 MHz crystal oscillator frequency divided by 750. To generate a 32.768 kHz RC oscillator frequency, use a 24.576 MHz crystal for the 26 MHz crystal oscillator.

#### 13.5.3 Sleep Timer Interrupt

The Sleep Timer generates the Sleep Timer interrupt, ST, when the timing event Event 0 occurs. This interrupt source can be masked using the `WORIRQ.EVENT0_MASK` interrupt mask bit. The interrupt flag bit `WORIRQ.EVENT0_FLAG` will be set when Event 0 occurs.

#### 13.5.4 Sleep Timer Registers

The SFR registers associated with the Sleep Timer are described in the following

## WORTIME0 (0xA5) – Sleep Timer Low Byte

Bit	Name	Reset	R/W	Description
7:0	WORTIME0[7:0]	0x00	R	Timer 16-bit value, low byte. The 16 bits are selected from the 31-bit Sleep Timer according to the setting of WORCTL.WOR_RES[1:0]

## WORTIME1 (0xA6) – Sleep Timer High Byte

Bit	Name	Reset	R/W	Description
7:0	WORTIME1[15:8]	0x00	R	Timer 16-bit value, high byte. The 16 bits are selected from the 31-bit Sleep Timer according to the setting of WORCTL.WOR_RES[1:0]

## WOREVT1 (0xA4) – Sleep Timer Event0 Timeout High

Bit	Name	Reset	R/W	Description
7:0	EVENT0[15:8]	0x87	R/W	High byte of Event 0 timeout register $t_{Event0} = \frac{750}{f_{XOSC}} \cdot EVENT0 \cdot 2^{5 \cdot WOR\_RES}$

## WOREVT0 (0xA3) – Sleep Timer Event0 Timeout Low

Bit	Name	Reset	R/W	Description
7:0	EVENT0[7:0]	107 (0x6B)	R/W	Low byte of Event 0 timeout register. The default Event 0 value gives 1.0s timeout, assuming a 26.0 MHz crystal.

## WORCTL (0xA2) – Sleep Timer Control

Bit	Name	Reset	R/W	Description								
7	–	0	R0	Not used								
6:4	–	111	R/W	Not used. Always write 111.								
3	–	-	R0	Not used								
2	WOR_RESET	0	R0/W1	Reset timer. If a 1 is written to this bit location, the timer is reset. Writing 0 will have no effect. Always read as 0								
1:0	WOR_RES[1:0]	00	R/W	<p>Timer resolution</p> <p>Controls the resolution and maximum timeout of the WOR timer. Adjusting the resolution does not affect the clock cycle counter:</p> <table border="0"> <tr> <td>00</td> <td>31.25 us resolution, 2 s max timeout (15:0)</td> </tr> <tr> <td>01</td> <td>1 ms resolution, 65 s max timeout (20:5)</td> </tr> <tr> <td>10</td> <td>32 ms resolution, 35 min max timeout (25:10)</td> </tr> <tr> <td>11</td> <td>1 s resolution, 18 h max timeout (30:15)</td> </tr> </table>	00	31.25 us resolution, 2 s max timeout (15:0)	01	1 ms resolution, 65 s max timeout (20:5)	10	32 ms resolution, 35 min max timeout (25:10)	11	1 s resolution, 18 h max timeout (30:15)
00	31.25 us resolution, 2 s max timeout (15:0)											
01	1 ms resolution, 65 s max timeout (20:5)											
10	32 ms resolution, 35 min max timeout (25:10)											
11	1 s resolution, 18 h max timeout (30:15)											

## WORIRQ (0xA1) – Sleep Timer Interrupt Control

Bit	Name	Reset	R/W	Description
7:6	–	00	R0	Not used
5	–	0	R/W	Not used. This bit must always be written as 0.
4	EVENT0_MASK	0	R/W	<p>Event 0 interrupt mask</p> <p>0 : interrupt is disabled</p> <p>1 : interrupt is enabled</p>
3:2	–	00	R0	Not used
1	–	0	R/W0	Not used. This bit must always be written as 0.
0	EVENT0_FLAG	0	R/W0	<p>Event 0 interrupt flag</p> <p>0 : no interrupt is pending</p> <p>1 : interrupt is pending</p>

### 13.6 8-bit Timer 3 and Timer 4

Timer 3 and 4 are 8-bit timers which support typical input capture and output compare operations using two capture/compare channels each. The timer allows general-purpose timer and waveform generation functions.

Features of Timer 3/4 are as follows:

- Dual channel operation
- Rising, falling or any edge input compare
- Set, clear or toggle output compare
- Free-running, modulo or up/down counter operation
- Clock prescaler for divide by 1, 2, 4, 8, 16, 32, 64, 128
- Interrupt request generated on each capture/compare and terminal count event
- DMA trigger function

#### 13.6.1 8-bit Timer Counter

All timer functions are based on the main 8-bit counter found in Timer 3/4. The counter increments or decrements at each active clock edge. The period of the active clock edges is defined by the register bits `CLKCON.TICKSPD` which is further divided by the prescaler value set by `TxCTL.DIV` (where x refers to the timer number, 3 or 4). The counter operates as either a free-running counter, a down counter, a modulo counter or as an up/down counter.

It is possible to read the 8-bit counter value through the SFR `TxCNT` where x refers to the timer number, 3 or 4.

The possibility to clear and halt the counter is given with `TxCTL` control register settings. The counter is started when a 1 is written to `TxCTL.START`. If a 0 is written to `TxCTL.START` the counter halts at its present value.

#### 13.6.2 Timer 3/4 Mode Control

In general the control register `TxCTL` is used to control the timer operation. The timer modes are described in the following sections.

##### 13.6.2.1 Free-running Mode

In the free-running mode of operation the counter starts from 0x00 and increments at each active clock edge. When the counter reaches 0xFF the counter is loaded with 0x00 and continues incrementing its value. When the terminal count value 0xFF is reached (i.e. an overflow occurs), the interrupt flag `TIMIF.TxOVFIIF` is set. If the corresponding interrupt mask bit `TxCTL.OVFIM` is set, an interrupt request is generated. The free-running mode can be used to generate independent time intervals and output signal frequencies.

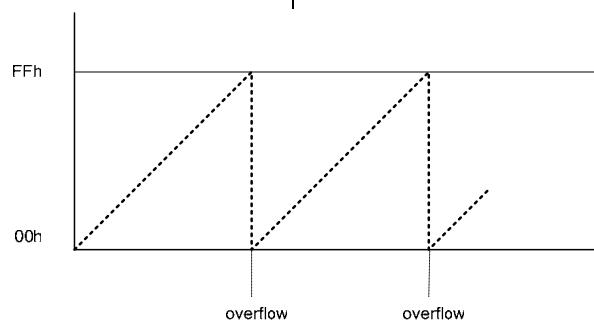

Figure 21 Free-running Mode

#### 13.6.2.2 Down mode

In the down mode, after the timer has been started, the counter is loaded with the contents in `TxCC`. The counter then counts down to 0x00 and remains at 0x00. The flag `TIMIF.TxOVFIIF` is set when 0x00 is reached.

If the corresponding interrupt mask bit `TxCTL.OVFIM` is set, an interrupt request is generated. The timer down mode can generally be used in applications where an event timeout interval is required.

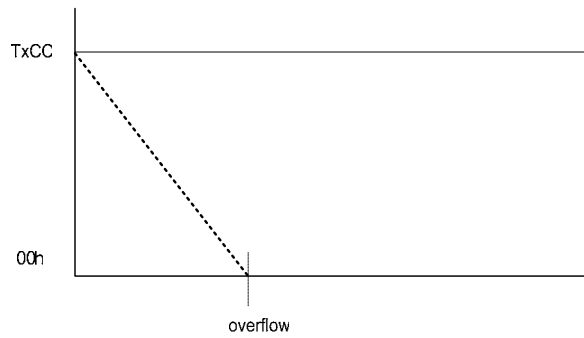

Figure 22 Down Mode

### 13.6.2.3 Modulo Mode

When the timer operates in modulo mode the 8-bit counter starts at 0x00 and increments at each active clock edge. When the counter reaches the value held in register TxCC the counter is reset to 0x00 and continues to increment. The flag TIMIF.TxOVFIIF is set on

this event. If the corresponding interrupt mask bit TxCTL.OVFIM is set, an interrupt request is generated. The modulo mode can be used for applications where a period other than 0xFF is required.

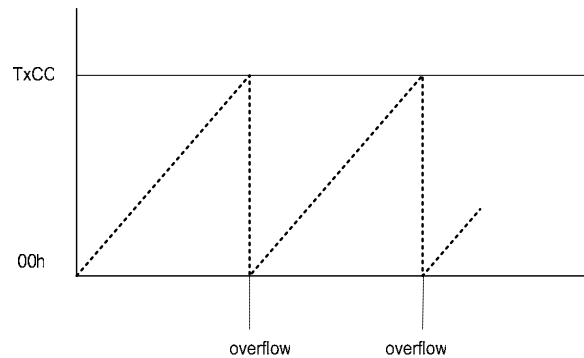

Figure 23 Modulo Mode

### 13.6.2.4 Up/down Mode

In the up/down timer mode, the counter repeatedly starts from 0x00 and counts up until the value held in TxCC is reached and then the counter counts down until 0x00 is reached. This timer mode is used when symmetrical output pulses are required with a period other

than 0xFF, and therefore allows implementation of centre-aligned PWM output applications.

The counter is reset to 0x00 by writing to TxCTL.CLR.

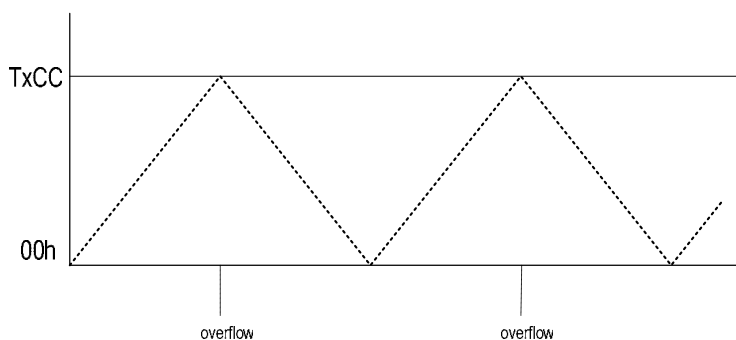

Figure 24 Up/down Mode

### 13.6.3 Channel Mode Control

The channel modes for each channel are set by the control and status registers  $TxCCCTLn$ , where  $n$  is the channel number, 0 or 1. The settings include input capture and output compare modes.

### 13.6.4 Input Capture Mode

When the channel is configured as an input capture channel, the I/O pin associated with that channel is configured as an input. After the timer has been started, either a rising edge, a falling edge or any edge on the input pin triggers a capture of the 8-bit counter contents into the associated capture register. Thus the timer is able to capture the time when an external event takes place.

The channel input pins are synchronized to the internal system clock. Thus pulses on the input pins must have a minimum duration greater than the system clock period.

*Note: before an input/output pin can be used by the timer, the required I/O pin must be configured as a Timer 3/4 peripheral pin as described in sections 13.1.4.4 and 13.1.4.5.*

The contents of the 8-bit capture registers, is read out from registers  $TxCCn$ .

When a capture takes place the interrupt flag corresponding to the actual channel is set. This interrupt flag is  $TIMIF.TxCHnIF$ . An interrupt request is generated if the corresponding interrupt mask bit  $TxCCCTLn.IM$  is set.

### 13.6.5 Output Compare Mode

In output compare mode the I/O pin associated with a channel should be configured as an output. After the timer has been started, the contents of the counter is compared with the

contents of the channel compare register  $TxCCn$ . If the compare register equals the counter contents, the output pin is set, reset or toggled according to the compare output mode setting of  $TxCCCTL.CMP1:0$ . Note that all edges on output pins are glitch-free when operating in a given compare output mode.

For simple PWM use, output compare modes 3 and 4 are preferred.

Writing to the compare register  $TxCC0$  does not take effect on the output compare value until the counter value is  $0x00$ . Writing to the compare register  $TxCC1$  takes effect immediately.

When a compare occurs the interrupt flag corresponding to the actual channel is set. This interrupt flag is  $TIMIF.TxCHnIF$ . An interrupt request is generated if the corresponding interrupt mask bit  $TxCCCTLn.IM$  is set.

### 13.6.6 Timer 3 and 4 interrupts

There is one interrupt vector assigned to each of the timers. These are T3IF (interrupt 11) and T4IF (interrupt 12). An interrupt request is generated when one of the following timer events occur:

- Counter reaches terminal count value.
- Input capture event.
- Output compare event

The SFR register  $TIMIF$  contains all interrupt flags for Timer 3 and Timer 4. The register bits  $TIMIF.TxOVFI$  and  $TIMIF.TxCHnIF$  contain the interrupt flags for the two terminal count value events and the four channel compare/capture events, respectively. An interrupt request is only generated when the corresponding interrupt mask bit is set. If there are other pending interrupts, the

corresponding interrupt flag must be cleared by the CPU before a new interrupt request can be generated. Also, enabling an interrupt mask bit will generate a new interrupt request if the corresponding interrupt flag is set.

When the timer is used in Free-running Mode or Modulo Mode the interrupt flags are set as follows:

- `TIMIF.TxCH0IF` and `TIMIF.TxCH1IF` are set on compare/capture event
- `TIMIF.TxOVFIF` is set when counter reaches terminal count value

When the timer is used in Up/Down Mode the interrupt flags are set as follows:

In compare mode:

- `TIMIF.TxCH0IF` and `TIMIF.TxOVFIF` are set when the counter turns around on zero
- `TIMIF.TxCH1IF` is set on compare event

In capture mode:

- `TIMIF.TxCH0IF` and `TIMIF.TxCH1IF` are set on capture event

- `TIMIF.TxOVFIF` is set when the counter turns around on zero

### 13.6.7 Timer 3 and Timer 4 DMA triggers

There are two DMA triggers associated with Timer 3 and two DMA triggers associated with Timer 4. These are DMA triggers `T3_CH0`, `T3_CH1`, `T4_CH0` and `T4_CH1` which are generated when the corresponding interrupt flags are set:

- `T3_CH0` is generated when `TIMIF.T3CH0IF` is set
- `T3_CH1` is generated when `TIMIF.T3CH1IF` is set
- `T4_CH0` is generated when `TIMIF.T4CH0IF` is set
- `T4_CH1` is generated when `TIMIF.T4CH1IF` is set

Refer to section 13.2 on page 84, for a description on use of DMA channels.

### 13.6.8 Timer 3 and 4 registers

The Timer 3 and 4 registers are described on the following pages.

## T3CNT (0xCA) – Timer 3 Counter

Bit	Name	Reset	R/W	Description
7:0	CNT[7:0]	0x00	R	Timer count byte. Contains the current value of the 8-bit counter.

## T3CTL (0xCB) – Timer 3 Control

Bit	Name	Reset	R/W	Description
7:5	DIV[2:0]	000	R/W	Prescaler divider value. Generates the active clock edge used to clock the timer from CLKCON.TICKSPD as follows: 000 Tick frequency /1 001 Tick frequency /2 010 Tick frequency /4 011 Tick frequency /8 100 Tick frequency /16 101 Tick frequency /32 110 Tick frequency /64 111 Tick frequency /128
4	START	0	R/W	Start timer. Normal operation when set, suspended when cleared
3	OVFIM	1	R/W0	Overflow interrupt mask 0 : interrupt is disabled 1 : interrupt is enabled
2	CLR	0	R0/W1	Clear counter. Writing high resets counter to 0x00
1:0	MODE[1:0]	00	R/W	Timer 3 mode. Select the mode as follows: 00 Free running, repeatedly count from 0x00 to 0xFF 01 Down, count from T3CC0 to 0x00 10 Modulo, repeatedly count from 0x00 to T3CC0 11 Up/down, repeatedly count from 0x00 to T3CC0 and down to 0x00



## T3CCTL0 (0xCC) – Timer 3 Channel 0 Capture/Compare Control

Bit	Name	Reset	R/W	Description
7	–	0	R0	Unused
6	IM	1	R/W	Channel 0 interrupt mask 0 : interrupt is disabled 1 : interrupt is enabled
5:3	CMP[ 2 : 0 ]	000	R/W	Channel 0 compare output mode select. Specified action on output when timer value equals compare value in T3CC0  000 Set output on compare 001 Clear output on compare 010 Toggle output on compare 011 Set output on compare-up, clear on 0 (clear on compare-down in up/down mode) 100 Clear output on compare-up, set on 0 (set on compare-down in up/down mode) 101 Set output on compare, clear on 0xFF 110 Clear output on compare, set on 0x00 111 Not used
2	MODE	0	R/W	Mode. Select Timer 3 channel 0 capture or compare mode 0 Capture mode 1 Compare mode
1:0	CAP[ 1 : 0 ]	00	R/W	Channel 0 capture mode select 00 No capture 01 Capture on rising edge 10 Capture on falling edge 11 Capture on all edges

## T3CC0 (0xCD) – Timer 3 Channel 0 Capture/Compare Value

Bit	Name	Reset	R/W	Description
7:0	VAL[ 7 : 0 ]	0x00	R/W	Timer capture/compare value channel 0

**T3CCTL1 (0xCE) – Timer 3 Channel 1 Capture/Compare Control**

Bit	Name	Reset	R/W	Description
7	–	0	R0	Unused
6	IM	1	R/W	Channel 1 interrupt mask 0 : interrupt is disabled 1 : interrupt is enabled
5:3	CMP[ 2 : 0 ]	000	R/W	Channel 1 compare output mode select. Specified action on output when timer value equals compare value in T3CC1  000 Set output on compare 001 Clear output on compare 010 Toggle output on compare 011 Set output on compare-up, clear on 0 (clear on compare-down in up/down mode) 100 Clear output on compare-up, set on 0 (set on compare-down in up/down mode) 101 Set output on compare, clear on T3CC0 110 Clear output on compare, set on T3CC0 111 Not used
2	MODE	0	R/W	Mode. Select Timer 3 channel 1 capture or compare mode 0 Capture mode 1 Compare mode
1:0	CAP[ 1 : 0 ]	00	R/W	Channel 1 capture mode select 00 No capture 01 Capture on rising edge 10 Capture on falling edge 11 Capture on all edges

**T3CC1 (0xCF) – Timer 3 Channel 1 Capture/Compare Value**

Bit	Name	Reset	R/W	Description
7:0	VAL[ 7 : 0 ]	0x00	R/W	Timer capture/compare value channel 1

**T4CNT (0xEA) – Timer 4 Counter**

Bit	Name	Reset	R/W	Description
7:0	CNT[ 7 : 0 ]	0x00	R	Timer count byte. Contains the current value of the 8-bit counter.

**T4CTL (0xEB) – Timer 4 Control**

Bit	Name	Reset	R/W	Description
7:5	DIV[2:0]	00	R/W	Prescaler divider value. Generates the active clock edge used to clock the timer from CLKCON.TICKSPD as follows:  000 Tick frequency /1 001 Tick frequency /2 010 Tick frequency /4 011 Tick frequency /8 100 Tick frequency /16 101 Tick frequency /32 110 Tick frequency /64 111 Tick frequency /128
4	START	0	R/W	Start timer. Normal operation when set, suspended when cleared
3	OVFIM	1	R/W0	Overflow interrupt mask
2	CLR	0	R0/W1	Clear counter. Writing high resets counter to 0x00
1:0	MODE[1:0]	00	R/W	Timer 4 mode. Select the mode as follows:  00 Free running, repeatedly count from 0x00 to 0x00 01 Down, count from T4CC0 to 0x00 10 Modulo, repeatedly count from 0x00 to T4CC0 11 Up/down, repeatedly count from 0x00 to T4CC0 and down to 0x00

## T4CCTL0 (0xEC) – Timer 4 Channel 0 Capture/Compare Control

Bit	Name	Reset	R/W	Description
7	–	0	R0	Unused
6	IM	1	R/W	Channel 0 interrupt mask
5:3	CMP[2:0]	000	R/W	Channel 0 compare output mode select. Specified action on output when timer value equals compare value in T4CC0 000 Set output on compare 001 Clear output on compare 010 Toggle output on compare 011 Set output on compare-up, clear on 0 (clear on compare-down in up/down mode) 100 Clear output on compare-up, set on 0 (set on compare-down in up/down mode) 101 Set output on compare, clear on 0x00 110 Clear output on compare, set on 0x00 111 Not used
2	MODE	0	R/W	Mode. Select Timer 4 channel 0 capture or compare mode 0 Capture mode 1 Compare mode
1:0	CAP[1:0]	00	R/W	Channel 0 capture mode select 00 No capture 01 Capture on rising edge 10 Capture on falling edge 11 Capture on all edges

## T4CC0 (0xED) – Timer 4 Channel 0 Capture/Compare Value

Bit	Name	Reset	R/W	Description
7:0	VAL[7:0]	0x00	R/W	Timer capture/compare value channel 0

## T4CCTL1 (0xEE) – Timer 4 Channel 1 Capture/Compare Control

Bit	Name	Reset	R/W	Description
7	–	0	R0	Unused
6	IM	1	R/W	Channel 1 interrupt mask
5:3	CMP[2:0]	000	R/W	Channel 1 compare output mode select. Specified action on output when timer value equals compare value in T4CC1 000 Set output on compare 001 Clear output on compare 010 Toggle output on compare 011 Set output on compare-up, clear on 0 (clear on compare-down in up/down mode) 100 Clear output on compare-up, set on 0 (set on compare-down in up/down mode) 101 Set output on compare, clear on T4CC0 110 Clear output on compare, set on T4CC0 111 Not used
2	MODE	0	R/W	Mode. Select Timer 4 channel 1 capture or compare mode 0 Capture mode 1 Compare mode
1:0	CAP[1:0]	00	R/W	Channel 1 capture mode select 00 No capture 01 Capture on rising edge 10 Capture on falling edge 11 Capture on all edges

## T4CC1 (0xEF) – Timer 4 Channel 1 Capture/Compare Value

Bit	Name	Reset	R/W	Description
7:0	VAL[7:0]	0x00	R/W	Timer capture/compare value channel 1

## TIMIF (0xD8) – Timers 1/3/4 Interrupt Mask/Flag

Bit	Name	Reset	R/W	Description
7	–	0	R0	Unused
6	OVFIM	1	R/W	Timer 1 overflow interrupt mask
5	T4CH1IF	0	R/W0	Timer 4 channel 1 interrupt flag 0 : no interrupt is pending 1 : interrupt is pending Writing a 1 has no effect.
4	T4CH0IF	0	R/W0	Timer 4 channel 0 interrupt flag 0 : no interrupt is pending 1 : interrupt is pending Writing a 1 has no effect.
3	T4OVFIIF	0	R/W0	Timer 4 overflow interrupt flag 0 : no interrupt is pending 1 : interrupt is pending Writing a 1 has no effect.
2	T3CH1IF	0	R/W0	Timer 3 channel 1 interrupt flag 0 : no interrupt is pending 1 : interrupt is pending Writing a 1 has no effect.
1	T3CH0IF	0	R/W0	Timer 3 channel 0 interrupt flag 0 : no interrupt is pending 1 : interrupt is pending Writing a 1 has no effect.
0	T3OVFIIF	0	R/W0	Timer 3 overflow interrupt flag 0 : no interrupt is pending 1 : interrupt is pending Writing a 1 has no effect.

## 13.7 ADC

### 13.7.1 ADC Introduction

The ADC supports up to 14-bit analog-to-digital conversion. The ADC includes an analog multiplexer with up to eight individually configurable channels, reference voltage generator and conversion results written to memory through DMA. Several modes of operation are available.

The main features of the ADC are as follows:

- Selectable decimation rates which also sets the resolution (8 to 14 bits).

- Eight individual input channels, single-ended or differential
- Reference voltage selectable as internal, external single ended, external differential or AVDD.
- Interrupt request generation
- DMA triggers at end of conversions
- Temperature sensor input
- Battery measurement capability

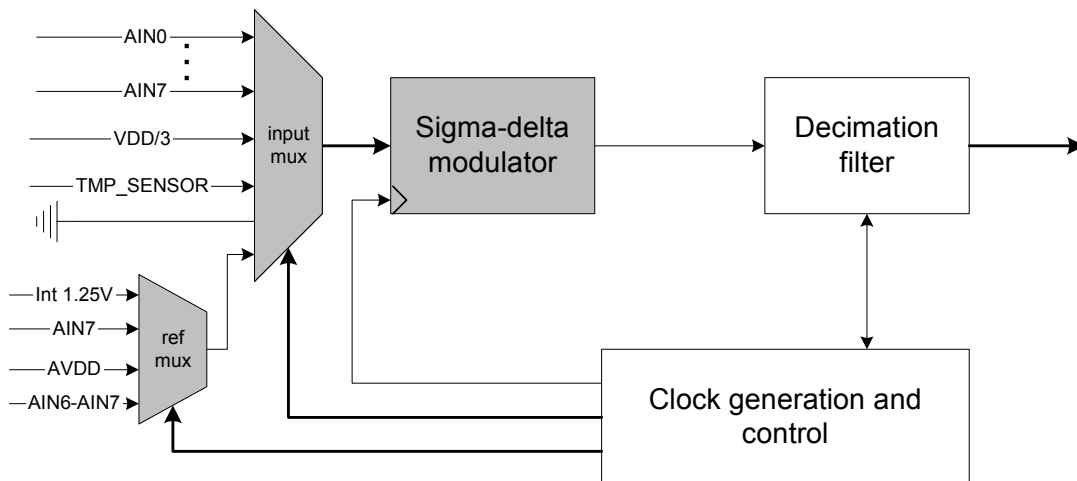

Figure 25: ADC block diagram.

### 13.7.2 ADC Operation

This section describes the general setup and operation of the ADC and describes the usage of the ADC control and status registers accessed by the CPU.

#### 13.7.2.1 ADC Core

The ADC includes an ADC capable of converting an analog input into a digital representation with up to 14 bits resolution. The ADC uses a selectable positive reference voltage.

#### 13.7.2.2 ADC Inputs

The signals on the P0 port pins can be used as ADC inputs. In the following these port pins will be referred to as the AIN0-AIN7 pins. The input pins AIN0-AIN7 are connected to the ADC. The ADC can be set up to automatically perform a sequence of conversions and optionally perform an extra conversion from any channel when the sequence is completed.

It is possible to configure the inputs as single-ended or differential inputs. In the case where differential inputs are selected,

the differential inputs consist of the input pairs AIN0-1, AIN2-3, AIN4-5 and AIN6-7.

In addition to the input pins AIN0-AIN7, the output of an on-chip temperature sensor can be selected as an input to the ADC for temperature measurements.

It is also possible to select a voltage corresponding to AVDD/3 as an ADC input. This input allows the implementation of e.g. a battery monitor in applications where this feature is required.

### 13.7.2.3 ADC conversion sequences

The ADC will perform a sequence of conversions, and move the results to memory (through DMA) without any interaction from the CPU.

The ADCCON2.SCH register bits are used to define an ADC conversion sequence, from the ADC inputs. A conversion sequence will contain a conversion from each channel from 0 up to and including the channel number programmed in ADCCON2.SCH when ADCCON2.SCH is set to a value less than 8.

The single-ended inputs AIN0 to AIN7 are represented by channel numbers 0 to 7 in ADCCON2.SCH. Channel numbers 8 to 11 represent the differential inputs consisting of AIN0-AIN1, AIN2-AIN3, AIN4-AIN5 and AIN6-AIN7. Channel numbers 12 to 15 represent GND, internal voltage reference, temperature sensor and AVDD/3, respectively.

When ADCCON2.SCH is set to a value between 8 and 12, the sequence will start at channel 8. For even higher settings, only single conversions are performed. In addition to this sequence of conversions, the ADC can be programmed to perform a single conversion from any channel as soon as the sequence has completed. This is called an extra conversion and is controlled with the ADCCON3 register.

The conversion sequence can also be influenced with the ADCCFG register (see section 13.1.5 on page 69). The eight analog inputs to the ADC come from I/O pins, which are not necessarily programmed to be analog inputs. If a channel should normally be part of a sequence, but the corresponding analog input is disabled in the ADCCFG, then that

channel will be skipped. For channels 8 to 12, both input pins must be enabled.

### 13.7.2.4 ADC Operating Modes

This section describes the operating modes and initialization of conversions.

The ADC has three control registers: ADCCON1, ADCCON2 and ADCCON3. These registers are used to configure the ADC and to report status.

The ADCCON1.EOC bit is a status bit that is set high when a conversion ends and cleared when ADCH is read.

The ADCCON1.ST bit is used to start a sequence of conversions. A sequence will start when this bit is set high, ADCCON1.STSEL="11" and no conversion is currently running. When the sequence is completed, this bit is automatically cleared.

The ADCCON1.STSEL bits select which event that will start a new sequence of conversions. The options which can be selected are rising edge on external pin P2\_0, end of previous sequence, a Timer 1 channel 0 compare event or ADCCON1.ST='1'.

The ADCCON2 register controls how the sequence of conversions is performed.

ADCCON2.SREF is used to select the reference voltage. The reference voltage should only be changed when no conversion is running.

The ADCCON2.SDIV bits select the decimation rate (and thereby also the resolution and time required to complete a conversion and sample rate). The decimation rate should only be changed when no conversion is running.

The last channel of a sequence is selected with the ADCCON2.SCH bits.

The ADCCON3 register controls the channel number, reference voltage and decimation rate for the extra conversion. The extra conversion will take place immediately after the ADCCON3 register is updated. The coding of the register bits is exactly as for ADCCON2.



### 13.7.2.5 ADC Conversion Results

The digital conversion result is represented in two's complement form. For 14-bit resolution, the digital conversion result is 8191 when the analogue input is equal to the VREF, and the conversion result is -8192 when the analogue input is equal to -VREF, where VREF is the selected positive voltage reference.

When single-ended input is used, only positive conversion results are generated effectively reducing the resolution to maximum 13 bits.

The digital conversion result is available when `ADCCON1.EOC` is set to 1, in `ADCH` and `ADCL`.

When reading the `ADCCON2.SCH` field, the number returned will indicate the last channel converted. Notice that when the value written to `ADCCON2.SCH` is less than 12, the number returned will be the number of the last channel converted + 1.

### 13.7.2.6 ADC Reference Voltage

The positive reference voltage for analogue-to-digital conversions is selectable as either an internally generated 1.25V voltage, the AVDD pin, the external voltage applied to the AIN7 input pin or the differential voltage applied to the AIN6-AIN7 inputs.

It is possible to select the reference voltage as the input to the ADC in order to perform a conversion of the reference voltage e.g. for calibration purposes. Similarly, it is possible to select the ground terminal GND as an input.

### 13.7.2.7 ADC Conversion Timing

The 26/48 MHz crystal oscillator should be selected when the ADC is used. The ADC runs on a clock which is the 26/48 MHz system clock source divided by 6 to give a 4.33/4 MHz ADC clock. The delta sigma modulator and decimation filter both use the ADC clock for their calculations.

The time required to perform a conversion depends on the selected decimation rate. When the decimation rate is set to for instance 128, the decimation filter uses exactly 128 of the ADC clock periods to calculate the result. When a conversion is started, the input multiplexer is allowed 16 ADC clock cycles to settle in case the channel has been changed since the previous conversion. The 16 clock cycles settling time applies to all decimation rates. Thus in general, the conversion time is given by:

$$T_{\text{conv}} = (\text{decimation rate} + 16) \times T$$

where

$$T = 0.23 \mu\text{s for CC2510Fx}$$

$$T = 0.25 \mu\text{s for CC2511Fx}$$

### 13.7.2.8 ADC Interrupts

The ADC will generate an interrupt when an extra conversion has completed. An interrupt is not generated when a conversion from the sequence is completed.

### 13.7.2.9 ADC DMA Triggers

The ADC will generate a DMA trigger every time a conversion from the sequence has completed. When an extra conversion completes, no DMA trigger is generated.

There is one DMA trigger for each of the eight channels defined by the first eight possible settings for `ADCCON2.SCH`. The DMA trigger is active when a new sample is ready from the conversion for the channel. The DMA triggers are named `ADC_CHx` in Table 42 on page 90.

In addition there is one DMA trigger, `ADC_CHALL`, which is active when new data is ready from any of the channels in the ADC conversion sequence.

### 13.7.2.10 ADC Registers

This section describes the ADC registers.

## ADCL (0xBA) – ADC Data Low

Bit	Name	Reset	R/W	Description
7:2	ADC[5:0]	0x00	R	Least significant part of ADC conversion result.
1:0	-	00	R0	Not used. Always read as 0

## ADCH (0xBB) – ADC Data High

Bit	Name	Reset	R/W	Description
7:0	ADC[13:6]	0x00	R	Most significant part of ADC conversion result.

## ADCCON1 (0xB4) – ADC Control 1

Bit	Name	Reset	R/W	Description
7	EOC	0	R H0	End of conversion Cleared when both ADCH and ADCL has been read. If a new conversion is completed before the previous data has been read, the EOC bit will remain high.  0 conversion not complete 1 conversion completed
6	ST	0	R/W1	Start conversion. Read as 1 until conversion has completed  0 no conversion in progress 1 start a conversion sequence if ADCCON1.STSEL = "11" and no sequence is running.
5:4	STSEL[1:0]	11	R/W	Start select. Selects which event that will start a new conversion sequence.  00 External trigger on P2_0 pin. 01 Full speed. Do not wait for triggers. 10 Timer1 channel1 output = 1 11 ADCCON1.ST = 1
3:2	RCTRL[1:0]	00	R/W	Controls the 16 bit random generator. When written "01", the setting will automatically return to "00" when operation has completed.  00 Idle or operation completed. 01 Clock the LFSR once (no unrolling). 10 Reserved. 11 Stopped. Random generator is turned off.
1:0	-	11	R/W	Reserved. Set to 11.

ADCCON2 (0xB5) – ADC Control 2

Bit	Name	Reset	R/W	Description																																
7:6	SREF[1:0]	00	R/W	<p>Selects reference voltage used for the sequence of conversions</p> <p>00 Internal 1.25V reference</p> <p>01 External reference on AIN7 pin</p> <p>10 AVDD pin</p> <p>11 External reference on AIN6-AIN7 differential input</p>																																
5:4	SDIV[1:0]	01	R/W	<p>Sets the decimation rate for channels included in the sequence of conversions. The decimation rate also determines the resolution and time required to complete a conversion.</p> <p>00 64 dec rate (8 bits resolution)</p> <p>01 128 dec rate (10 bits resolution)</p> <p>10 256 dec rate (12 bits resolution)</p> <p>11 512 dec rate (14 bits resolution)</p>																																
3:0	SCH[3:0]	00	R/W	<p>Sequence Channel Select. Selects the end of the sequence. A sequence can either be from AIN0 to AIN7 (SCH&lt;=7) or from the differential input AIN0-AIN1 to AIN6-AIN7 (8&lt;=SCH&lt;=11). For other settings, only single conversions are performed.</p> <p>When read, these bits will indicate the channel number of current conversion result when SCH &gt;= 12. When SCH &lt;= 11, these bits will indicate the channel number of current conversion result +1.</p> <table border="1"> <tbody> <tr><td>0000</td><td>AIN0</td></tr> <tr><td>0001</td><td>AIN1</td></tr> <tr><td>0010</td><td>AIN2</td></tr> <tr><td>0011</td><td>AIN3</td></tr> <tr><td>0100</td><td>AIN4</td></tr> <tr><td>0101</td><td>AIN5</td></tr> <tr><td>0110</td><td>AIN6</td></tr> <tr><td>0111</td><td>AIN7</td></tr> <tr><td>1000</td><td>AIN0-AIN1</td></tr> <tr><td>1001</td><td>AIN2-AIN3</td></tr> <tr><td>1010</td><td>AIN4-AIN5</td></tr> <tr><td>1011</td><td>AIN6-AIN7</td></tr> <tr><td>1100</td><td>GND</td></tr> <tr><td>1101</td><td>Positive voltage reference</td></tr> <tr><td>1110</td><td>Temperature sensor</td></tr> <tr><td>1111</td><td>AVDD/3</td></tr> </tbody> </table>	0000	AIN0	0001	AIN1	0010	AIN2	0011	AIN3	0100	AIN4	0101	AIN5	0110	AIN6	0111	AIN7	1000	AIN0-AIN1	1001	AIN2-AIN3	1010	AIN4-AIN5	1011	AIN6-AIN7	1100	GND	1101	Positive voltage reference	1110	Temperature sensor	1111	AVDD/3
0000	AIN0																																			
0001	AIN1																																			
0010	AIN2																																			
0011	AIN3																																			
0100	AIN4																																			
0101	AIN5																																			
0110	AIN6																																			
0111	AIN7																																			
1000	AIN0-AIN1																																			
1001	AIN2-AIN3																																			
1010	AIN4-AIN5																																			
1011	AIN6-AIN7																																			
1100	GND																																			
1101	Positive voltage reference																																			
1110	Temperature sensor																																			
1111	AVDD/3																																			

**ADCCON3 (0xB6) – ADC Control 3**

Bit	Name	Reset	R/W	Description
7:6	EREF[1:0]	00	R/W	<p>Selects reference voltage used for the extra conversion</p> <p>00 Internal 1.25V reference</p> <p>01 External reference on AIN7 pin</p> <p>10 AVDD pin</p> <p>11 External reference on AIN6-AIN7 differential input</p>
5:4	EDIV[1:0]	00	R/W	<p>Sets the decimation rate used for the extra conversion. The decimation rate also determines the resolution and time required to complete the conversion.</p> <p>00 64 dec rate (8 bits resolution)</p> <p>01 128 dec rate (10 bits resolution)</p> <p>10 256 dec rate (12 bits resolution)</p> <p>11 512 dec rate (14 bits resolution)</p>
3:0	ECH[3:0]	0000	R/W	<p>Extra channel select. Selects the channel number of the extra conversion that is carried out after a conversion sequence has ended. If the ADC is not running, writing to these bits will trigger an immediate single conversion from the selected extra channel. The bits are automatically cleared when the extra conversion has finished.</p> <p>0000 AIN0</p> <p>0001 AIN1</p> <p>0010 AIN2</p> <p>0011 AIN3</p> <p>0100 AIN4</p> <p>0101 AIN5</p> <p>0110 AIN6</p> <p>0111 AIN7</p> <p>1000 AIN0-AIN1</p> <p>1001 AIN2-AIN3</p> <p>1010 AIN4-AIN5</p> <p>1011 AIN6-AIN7</p> <p>1100 GND</p> <p>1101 Positive voltage reference</p> <p>1110 Temperature sensor</p> <p>1111 VDD/3</p>

## 13.8 Random Number Generator

### 13.8.1 Introduction

The random number generator has the following features.

- Generate pseudo-random bytes which can be read by the CPU.
- Calculate CRC16 of bytes that are written to RNDH.

- Seeded by value written to RNDL.

The random number generator is a 16-bit Linear Feedback Shift Register (LFSR) with polynomial  $X^{16} + X^{15} + X^2 + 1$  (i.e. CRC16). It uses different levels of unrolling depending on the operation it performs. The basic version (no unrolling) is shown below.

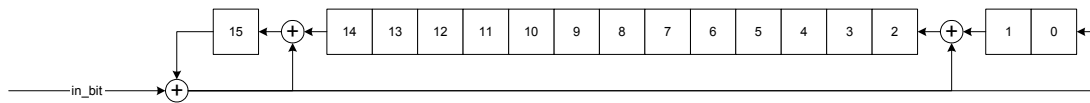

Figure 26: Basic structure of the Random Number Generator

The random number generator is turned off when `ADCCON1.RCTRL="11"`.

### 13.8.2 Random Number Generator Operation

The operation of the random number generator is controlled through a combination of the `ADCCON1.RCTRL` bits and input signals from other modules. The current value of the 16-bit shift register in the LFSR can be read from the `RNDH` and `RNDL` registers.

#### 13.8.2.1 Semi random sequence generation

The LFSR is updated by setting `ADCCON1.RCTRL="01"`. This will clock the LFSR once (no unrolling) and the `ADCCON1.RCTRL` bits will automatically be cleared when the operation has completed.

#### 13.8.2.2 Seeding

The LFSR is seeded from software by writing to the `RNDL` register twice. Each

time the `RNDL` register is written, the 8 LSB of the LFSR is copied to the 8 MSB and the 8 LSBs are replaced with the new data byte that was written to `RNDL`.

#### 13.8.2.3 CRC16

The LFSR can also be used to calculate the CRC value of a sequence of bytes. Writing to the `RNDH` register will trigger a CRC calculation. The new byte is processed from the MSB end and an 8x unrolling is used, so that a new byte can be written to `RNDH` every clock cycle.

Note that the LFSR must be properly seeded by writing to `RNDL`, before the CRC calculations start. Commonly used seed values are `0x0000` or `0xFFFF`.

#### 13.8.3 Registers

The random number generator registers are described in this section.

**RNDL (0xBC) – Random Number Generator Data Low Byte**

Bit	Name	Reset	R/W	Description
[7:0]	RNDL [ 7 : 0 ]	0xFF	R/W	<p>Random value/seed or CRC result, low byte</p> <p>When used for random number generation writing this register twice will seed the random number generator. Writing to this register copies the 8 LSBs of the LFSR to the 8 MSBs and replaces the 8 LSBs with the data value written.</p> <p>The value returned when reading from this register is the 8 LSBs of the LSFR.</p> <p>When used for random number generation, reading this register returns the 8 LSBs of the random number. When used for CRC calculations, reading this register returns the 8 LSBs of the CRC result.</p>

**RNDH (0xBD) – Random Number Generator Data High Byte**

Bit	Name	Reset	R/W	Description
[7:0]	RNDH [ 7 : 0 ]	0xFF	R/W	<p>Random value or CRC result/input data, high byte</p> <p>When written, a CRC16 calculation will be triggered, and the data value written is processed starting with the MSB bit.</p> <p>The value returned when reading from this register is the 8 MSBs of the LSFR.</p> <p>When used for random number generation, reading this register returns the 8 MSBs of the random number. When used for CRC calculations, reading this register returns the 8 MSBs of the CRC result.</p>

### 13.9 AES Coprocessor

With the *CC2510Fx/CC2511Fx*, data encryption can be performed using a dedicated coprocessor which supports Advanced Encryption Standard, AES. The coprocessor allows encryption/decryption to be performed with minimal CPU usage.

The coprocessor has the following features:

- ECB, CBC, CFB, OFB, CTR and CBC-MAC modes.
- Hardware support for CCM mode
- 128-bits key and IV/Nonce
- DMA transfer trigger capability

#### 13.9.1 AES Operation

To encrypt a message, the following procedure must be followed:

- Load key
- Load initialization vector (IV)
- Download and upload data for encryption/decryption.

The AES coprocessor works on blocks of 128 bits. A block of data is loaded into the coprocessor, encryption is performed and the result must be read out before the next block can be processed. Before each block load, a dedicated start command must be sent to the coprocessor.

#### 13.9.2 Key and IV

Before a key or IV/nonce load starts, an appropriate load key or IV must be issued to the coprocessor. When loading the IV it is important to also set the correct mode.

A key load or IV load operation aborts any processing that could be running.

The key, once loaded, stays valid until a key reload takes place.

The IV must be downloaded before the beginning of each message (not block).

Both key and IV are cleared by a reset.

#### 13.9.3 Padding of input data

AES works on blocks of 128 bits. If the last block contains less than 128 bits, it must

be padded with zeros when written to the coprocessor.

#### 13.9.4 Interface to CPU

The CPU communicates with the coprocessor using three SFR registers:

- ENCCS, Encryption control and status register
- ENCDI, Encryption input register
- ENCDO, Encryption output register

Read/write to the status register is done by the CPU, while read/write the input/output register is intended for use together with direct memory access (DMA).

Two DMA channels must be used, one for input data and one for output data. The DMA channels must be initialized before a start command is written to the ENCCS. Writing a start command generates a DMA trigger and the transfer is started. After each block is processed, an interrupt is generated. The interrupt is used to issue a new start command to the ENCCS.

#### 13.9.5 Modes of operation

ECB and CBC modes are performed as described in section 13.9.1

When using CFB, OFB and CTR mode, the 128 bits blocks are divided into four 32 bits blocks. 32 bits are loaded into the AES coprocessor and the resulting 32 bits are read out. This continues until all 128 bits are encrypted. The only time one has to consider this is if data is loaded/read directly using the CPU. When using DMA, this is handled automatically by the DMA triggers generated by the AES coprocessor.

Both encryption and decryption are performed similarly.

The CBC-MAC mode is a variant of the CBC mode. When performing CBC-MAC, data is downloaded to the coprocessor as one block at a time, except for the last block. Before the last block is loaded, the mode must be changed to CBC. The last block is then downloaded and the block uploaded will be the MAC value.

CCM is a combination of CBC-MAC and CTR. Parts of the CCM must therefore be done in software. The following section gives a short explanation of the necessary steps to be done.

13.9.5.1 CBC-MAC

When performing CBC-MAC encryption, data is only downloaded to the coprocessor in CBC-MAC mode except for the last block, one block at a time. Before the last block is loaded, the mode is changed to CBC. The last block is downloaded and the block uploaded is the message MAC.

CBC-MAC decryption is similar to encryption. The message MAC uploaded

must be compared with the MAC to be verified.

13.9.5.2 CCM mode

To encrypt a message under CCM mode, the following sequence can be conducted (key is already loaded):

**Message Authentication Phase**

This phase takes place during steps 1-6 shown in the following.

- (1) The software loads the IV with zeros.
- (2) The software creates the block B0. The layout of block B0 is shown in Figure 27.

	Name				Designation											
	B0				First block for authentication in CCM mode											
Byte	0	1	2	3	4	5	6	7	8	9	10	11	12	13	14	15
Name	Flag	NONCE						L_M								

Figure 27: Message Authentication Phase Block 0

There is no restriction on the NONCE value. L\_M is the message length in bytes.

The content of the Authentication Flag byte is described in Figure 28.

L is set to 6 in this example. So, L-1 is set to 5. M and A\_Data can be set to any value.

	Name		Designation					
	FLAG/B0		Authentication Flag Field for CCM mode					
Bit	7	6	5	4	3	2	1	0
Name	Reserved	A_Data	(M-2)/2			L-1		
Value	0	x	x	x	x	1	0	1

Figure 28: Authentication Flag Byte

(3) If some Additional Authentication Data (called a later) is needed (that is A\_Data =1), the software creates the A\_Data length field, called L(a) by :

- (3a) If l(a)=0, (that is A\_Data =0), then L(a) is the empty string. We note l(a) the length of a in octets.
- (3b) If  $0 < l(a) < 2^{16} - 2^8$ , then L(a) is the 2-octets encoding of l(a).



The Additional Authentication Data is appended to the A\_Data length field L(a). The Additional Authentication Blocks is padded with zeros until the last Additional Authentication Block is full. There is no restriction on the length of a.

AUTH-DATA = L(a) + Authentication Data + (zero padding)

(4) The last block of the message is padded with 0s until full (that is if its length is not a multiple of 128).

(5) The software concatenates the block B0, the Additional Authentication Blocks if any, and the message;

Input message = B0 + AUTH-DATA + Message + (zero padding of message)

(6) Once the input message authentication by CBC-MAC is finished, the software leaves the uploaded buffer contents unchanged (M=16), or keeps only the buffer's higher M bytes unchanged, while setting the lower bits to 0 (M != 16).

The result is called T.

**Message Encryption**

(7) The software creates the key stream block A0. Note that L=6, with the current example of the CTR generation. The content is shown in Figure 29:

	Name A0				Designation First CTR value for CCM mode											
Byte	0	1	2	3	4	5	6	7	8	9	10	11	12	13	14	15
Name	Flag	NONCE										CTR				

**Figure 29: Message Encryption Phase Block 0**

Note that any value but zero works for the CTR value.

The content of the Encryption Flag byte is described in Figure 30

	Name FLAG/A0		Designation Encryption Flag Field for CCM mode					
Bit	7	6	5	4	3	2	1	0
Name	Reserved		-			L-1		
Value	0	0	0	0	0	1	0	1

**Figure 30: Encryption Flag Byte**

(8) The software loads A0 by selecting a Load IV/Nonce command. To do so, it sets Mode to CFB or OFB at the same time it selects the Load IV/Nonce command.

(9) The software calls a CFB or an OFB encryption on the authenticated data T. The uploaded buffer contents stay unchanged (M=16), or only its first M bytes stay unchanged, the others being set to 0 (M-16). The result is U, which will be used later.

(10) The software calls a CTR mode encryption right now on the still padded message blocks. It does not have to reload the IV/CTR.

(11) The encrypted authentication data U is appended to the encrypted message. This gives the final result, c.

Result c = encrypted message(m) + U

**Message Decryption**

CCM Mode decryption

In the coprocessor, the automatic generation of CTR works on 32 bits, therefore the maximum length of a message is  $128 \times 2^{32}$  bits, that is  $2^{36}$  bytes, which can be written in a six-bit word. So, the value L is set to 6. To decrypt a CCM mode processed message, the following sequence can be conducted (key is already loaded):

**Message Parsing Phase**

- (1) The software parses the message by separating the M rightmost octets, namely U, and the other octets, namely string C.
- (2) C is padded with zeros until it can fill an integer number of 128-bit blocks;
- (3) U is padded with zeros until it can fill a 128-bit block.
- (4) The software creates the key stream block A0. It is done the same way as for CCM encryption.
- (5) The software loads A0 by selected a Load IV/Nonce command. To do so, it sets Mode to CFB or OFB at the same time it selects the IV load.
- (6) The software calls a CFB or an OFB encryption on the encrypted authenticated data U. The uploaded buffer contents stay unchanged (M=16), or only its first M bytes stay unchanged, the others being set to 0 (M!=16). The result is T.
- (7) The software calls a CTR mode decryption right now on the encrypted message blocks C. It does not have to reload the IV/CTR.

**Reference Authentication tag generation**

This phase is identical to the Authentication Phase of CCM encryption.

The only difference is that the result is named MACTag (instead of T).

**Message Authentication checking Phase**

The software compares T with MACTag.

*13.9.6 Sharing the AES coprocessor between layers*

The AES coprocessor is a common resource shared by all layers. The AES coprocessor can only be used by one instance one at a time. It is therefore necessary to implement some kind of software semaphore to allocate and de-allocate the resource.

*13.9.7 AES Interrupts*

The AES interrupt, ENC, is produced when encryption or decryption of a block is completed. The interrupt enable bit is IEN0.ENCIE and the interrupt flag is S0CON.ENCIF.

*13.9.8 AES DMA Triggers*

There are two DMA triggers associated with the AES coprocessor. These are ENC\_DW which is active when input data needs to be downloaded to the ENCDI register, and ENC\_UP which is active when output data needs to be uploaded from the ENCD0 register.

The ENCDI and ENCD0 registers should be set as destination and source locations for DMA channels used to transfer data to or from the AES coprocessor.

*13.9.9 AES Registers*

The AES coprocessor registers have the layout shown in this section.

## ENCCS (0xB3) – Encryption Control and Status

Bit	Name	Reset	R/W	Description
7	–	0	R0	Not used, always read as 0
6:4	MODE[2:0]	000	R/W	Encryption/decryption mode 000 CBC 001 CFB 010 OFB 011 CTR 100 ECB 101 CBC MAC 110 Not used 111 Not used
3	RDY	1	R	Encryption/decryption ready status 0 Encryption/decryption in progress 1 Encryption/decryption is completed
2:1	CMD[1:0]	0	R/W	Command to be performed when a 1 is written to ST. 00 encrypt block 01 decrypt block 10 load key 11 load IV/nonce
0	ST	0	R/W1 H0	Start processing command set by CMD. Must be issued for each command or 128 bits block of data. Cleared by hardware

## ENCDI (0xB1) – Encryption Input Data

Bit	Name	Reset	R/W	Description
7:0	DIN[7:0]	0x00	R/W	Encryption input data

## ENCDO (0xB2) – Encryption Output Data

Bit	Name	Reset	R/W	Description
7:0	DOU[7:0]	0x00	R/W	Encryption output data

## 13.10 Power Management

This section describes the Power Management Controller. The Power Management Controller controls the use of power modes and clock control to achieve low-power operation.

### 13.10.1 Power Management Introduction

The *CC2510Fx/CC2511Fx* uses different operating modes, or power modes, to allow low-power operation. Ultra-low-power operation is obtained by turning off power supply to modules to avoid static (leakage) power consumption and also by using clock gating to reduce dynamic power consumption.

The various operating modes are enumerated and shall be designated as power modes (PMx). The power modes are:

- PM0  
Clock oscillators on, voltage regulator on
- PM1  
32.768/34 kHz oscillators on, voltage regulator on
- PM2  
32.768/34 kHz oscillators on, voltage regulator off
- PM3  
All clock oscillators off, voltage regulator off

#### 13.10.1.1 PM0

PM0 is the full functional mode of operation where the CPU and peripherals are active. The voltage regulator is turned on.

PM0 is used for normal operation.

#### 13.10.1.2 PM1

In PM1, the high-speed oscillators are powered down thereby halting the CPU and peripherals. The voltage regulator, the power-on reset, external interrupts, the 32.768/34 kHz oscillators and sleep timer peripherals are active. I/O pins retain the I/O mode and output value set before entering PM1. When PM1 is entered, a power down sequence is run. When the device is taken out of PM1 to PM0, the

high-speed oscillators are started. The device will run on the high speed RC oscillator until the high speed crystal oscillator has settled and has been selected.

PM1 is used when the expected time until a wakeup event is relatively short since PM1 uses a fast power down/up sequence.

#### 13.10.1.3 PM2

PM2 has the second lowest power consumption. In PM2 the power-on reset, external interrupts, 32.768/34 kHz oscillators and sleep timer peripherals are active. I/O pins retain the I/O mode and output value set before entering PM2. All other internal circuits are powered down. The voltage regulator is also turned off. When PM2 is entered, a power down sequence is run.

PM2 is used when it is relatively long until the expected time of a wakeup event, since the power up/down sequence is relatively long. PM2 is typically entered when using the sleep timer as the wakeup event.

#### 13.10.1.4 PM3

PM3 is used to achieve the operating mode with the lowest power consumption. In PM3 all internal circuits that are powered from the voltage regulator are turned off. The internal voltage regulator and all oscillators are also turned off.

Power-on reset and external interrupts are the only functions that are operating in this mode. I/O pins retain the I/O mode and output value set before entering PM3. Only a reset or external interrupt condition will wake the device up and place it into PM0. The contents of RAM and registers are preserved in this mode. PM3 uses the same power down/up sequence as PM2.

PM3 is used to achieve ultra low power consumption when waiting for an external event.

### 13.10.2 Power Management Control

The required power mode is selected by the `MODE` bits in the `SLEEP` control

register. Setting the SFR register `PCON.IDLE` bit after setting the `MODE` bits, enters the selected power mode.

An interrupt from port pins, or sleep timer (not PM3) or a power-on reset will wake the device and bring it into PM0 by resetting the `MODE` bits.

### 13.10.3 System Clock

The system clock is derived from the selected main clock source, which is the high-speed (26/48 MHz) crystal oscillator or the high-speed (13 MHz) RC oscillator. The `CLKCON.OSC` bit selects the source of the main system clock. Note that to use the RF transceiver the high speed crystal oscillator must be selected and stable.

When the `SLEEP.XOSC_STB` is 1, the 26/48 MHz crystal oscillator is stable and can be used as the source for the system clock.

The oscillator not selected as the system clock source, will be set in power-down mode by setting `SLEEP.OSC_PD` to 1. Thus the high-speed RC oscillator may be turned off when the 26/48 MHz crystal oscillator has been selected as system clock source and vice versa. When `SLEEP.OSC_PD` is 0, both oscillators are powered up and running.

The selected main clock source can be divided down by setting the `CLKCON.CLKSPD` register appropriately. Eight different system clock frequencies from 0.203 to 26 MHz for **CC2510Fx** or from 0.1875 to 24 MHz for **CC2511Fx** can be used.

### 13.10.4 High-speed oscillators

Two high speed oscillators are present in the device. The high-speed crystal oscillator startup time may be too long for some applications, therefore the device will run on the high-speed RC oscillator until crystal oscillator is stable. The high-speed RC oscillator consumes less power than the crystal oscillator, but since it is not as accurate as the crystal oscillator it can not be used for RF transceiver operation.

### 13.10.5 32.768/34 kHz oscillators

Two low power oscillators are present in the device. By default the low power RC oscillator is enabled (see Table 12 on page 16). The low power RC oscillator consumes less power, but is less accurate than the 32.768 kHz crystal oscillator. When the high speed crystal oscillator is running the low power RC oscillator is continuously calibrated. It is calibrated to a frequency equal to high speed crystal frequency divided by 750. E.g. 34.67 kHz with 26 MHz crystal (**CC2510Fx**) and 32 kHz with 24 MHz crystal (**CC2511Fx**).

### 13.10.6 Timer Tick generation

The power management controller generates a tick or enable signal for the peripheral timers, thus acting as a prescaler for the timers. This is a global clock division for Timer 1, Timer 3 and Timer 4. The tick speed is programmed from 0.203 to 26 MHz for **CC2510Fx** or from 0.1875 to 24 MHz for **CC2511Fx** by setting the `CLKCON.TICKSPD` register appropriately.

*Note: The `CLKCON.TICKSPD` register cannot be set higher than `CLKCON.CLKSPD`.*

### 13.10.7 Data Retention

In power modes PM2 and PM3 parts of SRAM will retain its contents. The content of internal registers is also retained in PM2/3.

The XDATA memory locations 0xF000-0xFFFF (4096 bytes) retains data in PM2/3. Please note one exception as given below.

The XDATA memory locations 0xFDA2-0xFEFF (350 bytes) will lose all data when PM2/3 is entered. These locations will contain undefined data when PM0 is re-entered.

The registers which retain their contents are the CPU registers, peripheral registers and RF registers, therefore switching to the low-power modes PM2/3 appears transparent to software.

### 13.10.8 I/O and Radio

I/O port pins P1\_0 and P1\_1 do not have internal pull-up/pull-down resistors. These

pins should therefore be set as outputs or pulled high/low externally to avoid leakage current.

To save power, the radio should be turned off when it is not used.

### 13.10.9 Power Management Registers

This section describes the Power Management registers.

#### PCON (0x87) – Power Mode Control

Bit	Name	Reset	R/W	Description
7:2	–	0x00	R/W	Not used.
1	–	0	R0	Not used, always read as 0.
0	IDLE	0	R0/W H0	Power mode control. Writing a 1 to this bit forces entry to the power mode set by SLEEP.MODE. This bit is always read as 0

#### SLEEP (0xBE) – Sleep Mode Control

Bit	Name	Reset	R/W	Description
7	USB_EN	0	R/W	USB Enable ( <i>CC2511Fx</i> ). This bit is unused for <i>CC2510Fx</i> . 0 – USB Disabled 1 – USB Enabled
6	XOSC_STB	0	R	26/48 MHz Crystal oscillator stable status: 0 – oscillator is not powered up or not yet stable 1 – oscillator is powered up and stable
5	HFRC_STB	0	R	High speed RC oscillator stable status: 0 – oscillator is not powered up or not yet stable 1 – oscillator is powered up and stable
4:3	RST[1:0]	XX	R	Reserved.
2	OSC_PD	1	R/W H0	XOSC and HS RCOSC power down setting. The bit is cleared if the CLKCON.OSC bit is toggled. Also, if there is a calibration in progress and the CPU attempts to set the bit, the bit will be updated at the end of calibration: 0 – Both oscillators powered up 1 – Oscillator not selected by CLKCON.OSC bit powered down
1:0	MODE[1:0]	00	R/W	Sleep mode setting: 00 – Power mode 0 01 – Power mode 1 10 – Power mode 2 11 – Power mode 3

**CLKCON (0xC6) – Clock Control**

Bit	Name	Reset	R/W	Description																											
7	OSC32K	1	R/W	32 kHz clock oscillator select: 0 – 32.768 kHz crystal oscillator 1 – 34 kHz low power RC oscillator																											
6	OSC	1	R/W	Main clock oscillator select: 0 – 26/48 MHz crystal oscillator 1 – 13 MHz HF RC oscillator  This setting will only take effect when the selected oscillator is powered up and stable. If the selected oscillator is not powered up, then writing this bit will power it up.																											
5:3	TICKSPD[2:0]	001	R/W	Timer ticks output setting. The value of TICKSPD cannot be higher than CLKSPD.  <table border="1"> <thead> <tr> <th></th> <th><i>CC2510Fx</i></th> <th><i>CC2511Fx</i></th> </tr> </thead> <tbody> <tr> <td>000</td> <td>26 MHz</td> <td>24 MHz</td> </tr> <tr> <td>001</td> <td>13 MHz</td> <td>12 MHz</td> </tr> <tr> <td>010</td> <td>6.5 MHz</td> <td>6 MHz</td> </tr> <tr> <td>011</td> <td>3.25 MHz</td> <td>3 MHz</td> </tr> <tr> <td>100</td> <td>1.625 MHz</td> <td>1.5 MHz</td> </tr> <tr> <td>101</td> <td>812.5 kHz</td> <td>750 kHz</td> </tr> <tr> <td>110</td> <td>406.25 kHz</td> <td>325 kHz</td> </tr> <tr> <td>111</td> <td>203.125 kHz</td> <td>162.5 kHz</td> </tr> </tbody> </table>		<i>CC2510Fx</i>	<i>CC2511Fx</i>	000	26 MHz	24 MHz	001	13 MHz	12 MHz	010	6.5 MHz	6 MHz	011	3.25 MHz	3 MHz	100	1.625 MHz	1.5 MHz	101	812.5 kHz	750 kHz	110	406.25 kHz	325 kHz	111	203.125 kHz	162.5 kHz
	<i>CC2510Fx</i>	<i>CC2511Fx</i>																													
000	26 MHz	24 MHz																													
001	13 MHz	12 MHz																													
010	6.5 MHz	6 MHz																													
011	3.25 MHz	3 MHz																													
100	1.625 MHz	1.5 MHz																													
101	812.5 kHz	750 kHz																													
110	406.25 kHz	325 kHz																													
111	203.125 kHz	162.5 kHz																													
2:0	CLKSPD[2:0]	001	R/W	Clock speed setting. When a new CLKSPD value is written, the new setting is read when the clock has changed.  <table border="1"> <thead> <tr> <th></th> <th><i>CC2510Fx</i></th> <th><i>CC2511Fx</i></th> </tr> </thead> <tbody> <tr> <td>000</td> <td>26 MHz</td> <td>24 MHz</td> </tr> <tr> <td>001</td> <td>13 MHz</td> <td>12 MHz</td> </tr> <tr> <td>010</td> <td>6.5 MHz</td> <td>6 MHz</td> </tr> <tr> <td>011</td> <td>3.25 MHz</td> <td>3 MHz</td> </tr> <tr> <td>100</td> <td>1.625 MHz</td> <td>1.5 MHz</td> </tr> <tr> <td>101</td> <td>812.5 kHz</td> <td>750 kHz</td> </tr> <tr> <td>110</td> <td>406.25 kHz</td> <td>325 kHz</td> </tr> <tr> <td>111</td> <td>203.125 kHz</td> <td>162.5 kHz</td> </tr> </tbody> </table>		<i>CC2510Fx</i>	<i>CC2511Fx</i>	000	26 MHz	24 MHz	001	13 MHz	12 MHz	010	6.5 MHz	6 MHz	011	3.25 MHz	3 MHz	100	1.625 MHz	1.5 MHz	101	812.5 kHz	750 kHz	110	406.25 kHz	325 kHz	111	203.125 kHz	162.5 kHz
	<i>CC2510Fx</i>	<i>CC2511Fx</i>																													
000	26 MHz	24 MHz																													
001	13 MHz	12 MHz																													
010	6.5 MHz	6 MHz																													
011	3.25 MHz	3 MHz																													
100	1.625 MHz	1.5 MHz																													
101	812.5 kHz	750 kHz																													
110	406.25 kHz	325 kHz																													
111	203.125 kHz	162.5 kHz																													

### 13.11 Power On Reset

The *CC2510Fx/CC2511Fx* includes a Power On Reset (POR) in order to protect the memory contents during supply voltage variations and provide correct initialization during power-on.

When power is initially applied to the *CC2510Fx/CC2511Fx* the Power On Reset (POR) will hold the device in reset state until the supply voltage reaches above the Power On Reset voltage as defined in Table 5 on page 11.

Figure 31 shows the POR operation with the 1.8V (typical) regulated supply voltage together with the active low reset signal shown in the bottom of the figure.

The cause of the last reset can read from the register bits `SLEEP.RST`.

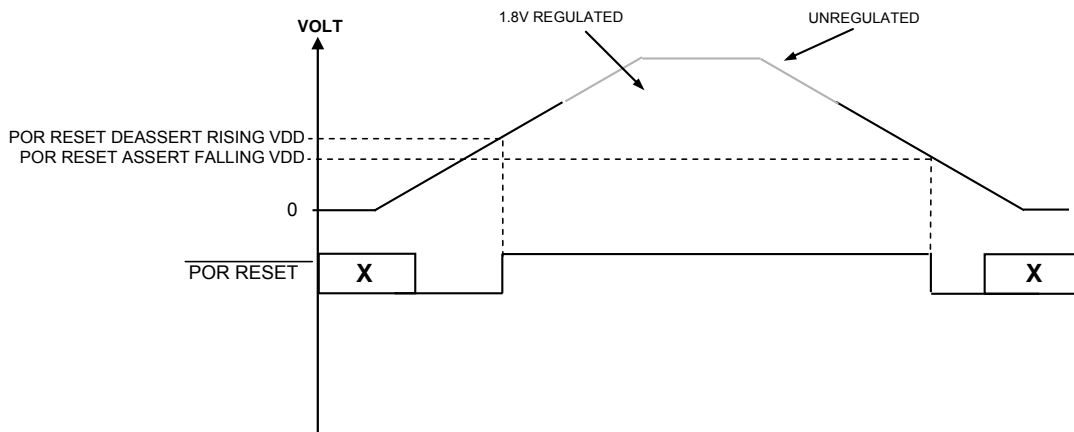

Figure 31 : Power On Reset Operation



### 13.12 Watchdog Timer

The watchdog timer (WDT) is intended as a recovery method in situations where the software hangs. The WDT shall reset the system when software fails to clear the WDT within a selected time interval. The watchdog can be used in applications that are subject to electrical noise, power glitches, electrostatic discharge etc., or where high reliability is required. If the watchdog function is not needed in an application, it is possible to configure the watchdog timer to be used as an interval timer that can be used to generate interrupts at selected time intervals.

The features of the watchdog timer are as follows:

- Four selectable timer intervals
- Watchdog mode
- Timer mode
- Interrupt request generation in timer mode
- Clock independent from system clock

The WDT is configured as either a watchdog timer or as a timer for general-purpose use. The operation of the WDT module is controlled by the `WDCTL` register. The watchdog timer consists of an 15-bit counter clocked by the 32.768 oscillator or 32 - 34 kHz rc clock. Note that the contents of the 15-bit counter is not user-accessible.

#### 13.12.1 Watchdog mode

The watchdog timer is disabled after a system reset. To set the WDT in watchdog mode the `WDCTL.MODE` bit is set to 0. The watchdog timer counter starts incrementing when the enable bit `WDCTL.EN` is set to 1. When the timer is enabled in watchdog mode it is not possible to disable the timer. Therefore, writing a 0 to `WDCTL.EN` has no effect if a 1 was already written to this bit when `WDCTL.MODE` was 0.

The WDT can operate with a watchdog timer clock frequency of 32.768 kHz. This clock frequency gives time-out periods equal to 1.9 ms, 15.625 ms, 0.25 s and 1 s corresponding to the count value settings 64, 512, 8192 and 32768 respectively.

If the counter reaches the selected timer interval value, the watchdog timer generates a reset signal for the system. If a watchdog clear sequence is performed before the counter reaches the selected timer interval value, the counter is reset to 0x0000 and continues incrementing its value. The watchdog clear sequence consists of writing 0xA to `WDCTL.CLR[3:0]` followed by writing 0x5 to the same register bits within one half of a watchdog clock period. If this complete sequence is not performed, the watchdog timer generates a reset signal for the system. Note that as long as a correct watchdog clear sequence begins within the selected timer interval, the counter is reset when the complete sequence has been received.

When the watchdog timer has been enabled in watchdog mode, it is not possible to change the mode by writing to the `WDCTL.MODE` bit. The timer interval value can be changed by writing to the `WDCTL.INT[1:0]` bits.

Note that it is recommended that user software clears the watchdog timer at the same time as the timer interval value is changed, in order to avoid an unwanted watchdog reset.

In watchdog mode, the WDT does not produce an interrupt request.

#### 13.12.2 Timer mode

To set the WDT in normal timer mode, the `WDCTL.MODE` bit is set to 1. When register bit `WDCTL.EN` is set to 1, the timer is started and the counter starts incrementing. When the counter reaches the selected interval value, the timer will produce an interrupt request.

In timer mode, it is possible to clear the timer contents by writing a 1 to `WDCTL.CLR[0]`. When the timer is cleared the contents of the counter is set to 0x0000. Writing a 0 to the enable bit `WDCTL.EN` stops the timer and writing 1 restarts the timer from 0x0000.

The timer interval is set by the `WDCTL.INT[1:0]` bits. In timer mode, a

reset will not be produced when the timer interval has been reached.

13.12.3 Watchdog Timer Example

Figure 32 shows an example of periodical clearing of an active watchdog timer.

```
; clear watchdog timer
MOV   WDCTL, #ABh
MOV   WDCTL, #5Bh
```

Figure 32: WDT Example

13.12.4 Watchdog Timer Register

This section describes the register for the Watchdog Timer.

WDCTL (0xC9) – Watchdog Timer Control

Bit	Name	Reset	R/W	Description
7:4	CLR[3:0]	0000	R/W	Clear timer. When 0xA followed by 0x5 is written to these bits, the timer is loaded with 0x0. Note the timer will only be cleared when 0x5 is written within 0.5 watchdog clock period after 0xA was written. Writing to these bits when EN is 0 has no effect. These bits are always be read as 0000.
3	EN	0	R/W	Enable timer. When a 1 is written to this bit the timer is enabled and starts incrementing. Writing a 0 to this bit in timer mode stops the timer. Writing a 0 to this bit in watchdog mode has no effect. 0 Timer disabled (stop timer) 1 Timer enabled
2	MODE	0	R/W	Mode select. This bit selects the watchdog timer mode. 0 Watchdog mode 1 Timer mode
1:0	INT[1:0]	00	R/W	Timer interval select. These bits select the timer interval defined as a given number of 32.768 or 34 kHz oscillator periods. 00 clock period x 32768 (typical 1 s) 01 clock period x 8192 (typical 0.25 s) 10 clock period x 512 (typical 15.625 ms) 11 clock period x 64 (typical 1.9 ms)

### 13.13 USART

USART0 and USART1 are serial communications interfaces that can be operated separately in either asynchronous UART mode or in synchronous SPI mode. The two USARTs have identical function, and are assigned to separate I/O pins. Refer to section 13.1 for I/O configuration.

#### 13.13.1 UART mode

For asynchronous serial interfaces, the UART mode is provided. In the UART mode the interface uses a two-wire interface consisting of the pins RXD and TXD. The UART mode of operation includes the following features:

- 8 or 9 data bits
- Odd, even or no parity
- Configurable start and stop bit level
- Configurable LSB or MSB first transfer
- Independent receive and transmit interrupts
- Independent receive and transmit DMA triggers
- Parity and framing error status

The UART mode provides full duplex asynchronous transfers, and the synchronization of bits in the receiver does not interfere with the transmit function. A UART byte transfer consists of a start bit, eight data bits, an optional ninth data or parity bit, and one or two stop bits. Note that the data transferred is referred to as a byte, although the data can actually consist of eight or nine bits.

The UART operation is controlled by the USART Control and Status registers, UxCSR and the UART Control register UxUCR where x is the USART number, 0 or 1.

The UART mode is selected when UxCSR.MODE is set to 1.

##### 13.13.1.1 UART Transmit

A UART transmission is initiated when the USART Receive/Transmit Data Buffer, UxDBUF register is written. The byte is

transmitted on the TXDx output pin. The UxDBUF register is double-buffered.

The UxCSR.ACTIVE bit goes high when the byte transmission starts and low when it ends. When byte transmission ends the UxCSR.TX\_BYTE bit is set. An interrupt request is generated when the UxDBUF register is ready to accept new transmit data. This happens immediately after the transmission has been started, hence a new data byte value can be loaded into the data buffer while a byte is being transmitted.

##### 13.13.1.2 UART Receive

Data reception on the UART is initiated when a 1 is written to the UxCSR.RE bit. The UART will then search for a valid start bit on the RXDx input pin and set the UxCSR.ACTIVE bit high. When a valid start bit has been detected the received byte is shifted into the receive register. The UxCSR.RX\_BYTE bit is set when the operation has completed, and a receive interrupt is generated. At the same time UxCSR.ACTIVE will go low.

The received data byte is available through the UxDBUF register. When UxDBUF is read, UxCSR.RX\_BYTE is cleared by hardware.

##### 13.13.1.3 UART Character Format

If the BIT9 and PARITY bits in register UxUCR are set high, parity generation and detection is enabled. The parity is computed and transmitted as the ninth bit, and during reception, the parity is computed and compared to the received ninth bit. If there is a parity error, the UxCSR.ERR bit is set high. This bit is cleared when UxCSR is read.

The number of stop bits to be transmitted is set to one or two bits determined by the register bit UxUCR.SPB. The receiver will always check for one stop bit. If the first stop bit received during reception is not at the expected stop bit level, a framing error is signaled by setting register bit UxCSR.FE high. UxCSR.FE is cleared when UxCSR is read. The receiver will

check both stop bits when `UxUCR.SPB` is set.

### 13.13.2 SPI Mode

This section describes the SPI mode of operation for synchronous communication. In SPI mode, the USART communicates with an external system through a 3-wire or 4-wire interface. The interface consists of the pins MOSI, MISO, SCK and SSN. Refer to section 13.1 for description of how the USART pins are assigned to the I/O pins.

The SPI mode includes the following features:

- Master and slave modes
- Configurable SCK polarity and phase
- Configurable LSB or MSB first transfer

The SPI mode is selected when `UxCSR.MODE` is set to 0.

In SPI mode, the USART can be configured to operate either as an SPI master or as an SPI slave by writing the `UxCSR.SLAVE` bit.

#### 13.13.2.1 SPI Master Operation

An SPI byte transfer in master mode is initiated when the `UxDBUF` register is written. The USART generates the SCK serial clock using the baud rate generator (see section 13.13.3) and shifts the provided byte from the transmit register onto the MOSI output. At the same time the receive register shifts in the received byte from the MISO input pin.

The `UxCSR.ACTIVE` bit goes high when the transfer starts and low when the transfer ends. When the transfer ends, the `UxCSR.RX_BYTE` and `UxCSR.TX_BYTE` bits are set. A receive interrupt is generated when new received data is ready in the `UxDBUF` USART Receive/Transmit Data register.

The polarity and clock phase of the serial clock SCK is selected by `UxGCR.CPOL` and `UxGCR.CPHA` as shown in Figure 33. The order of the byte transfer is selected by the `UxGCR.ORDER` bit.

At the end of the transfer, the received data byte is available for reading from the `UxDBUF` register.

A transmit interrupt is generated when the unit is ready to accept another data byte for transmission. Since `UxDBUF` is double-buffered, this happens just after the transmission has been initiated.

#### 13.13.2.2 SPI Slave Operation

An SPI byte transfer in slave mode is controlled by the external system. The data on the MOSI input is shifted into the receive register controlled by the serial clock SCK which is an input in slave mode. At the same time the byte in the transmit register is shifted out onto the MISO output.

The `UxCSR.ACTIVE` bit goes high when the transfer starts and low when the transfer ends. Then the `UxCSR.RX_BYTE` and `UxCSR.TX_BYTE` bits are set and a receive interrupt is generated.

The expected polarity and clock phase of SCK is selected by `UxGCR.CPOL` and `UxGCR.CPHA` as shown in Figure 33. The expected order of the byte transfer is selected by the `UxGCR.ORDER` bit.

At the end of the transfer, the received data byte is available for reading from the `UxDBUF` register.

The transmit interrupt is generated at the start of the operation.

#### 13.13.2.3 Slave Select pin (SSN)

When the USART is operating in SPI mode, configured as an SPI slave, the Slave Select (SSN) pin is an input to the SPI. When SSN is held low, the SPI slave is active and receives data on the MOSI input and outputs data on the MISO output. When SSN is held high, the SPI slave is inactive and will not receive data.

In SPI master mode, the SSN pin is not used. When the device operates as an SPI master and a slave select signal is needed by an external SPI slave device, then a general purpose I/O pin should be used to implement the slave select signal function in software.

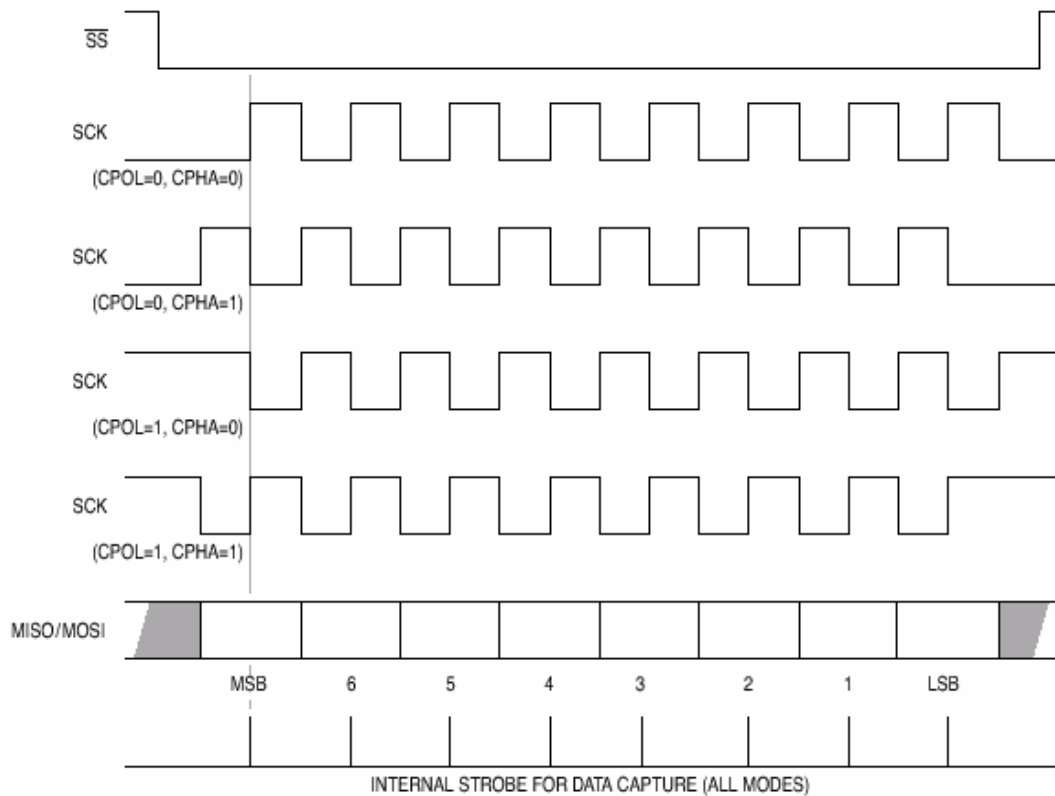

Figure 33: SPI Dataflow

### 13.13.3 Baud Rate Generation

An internal baud rate generator sets the UART baud rate when operating in UART mode and the SPI master clock frequency when operating in SPI mode.

The `UxBAUD.BAUD_M[7:0]` and `UxGCR.BAUD_E[4:0]` registers define the baud rate used for UART transfers and the rate of the serial clock for SPI transfers. The baud rate is given by the following equation:

$$\text{Baudrate} = \frac{(256 + \text{BAUD\_M}) * 2^{\text{BAUD\_E}}}{2^{28}} * F$$

where  $F$  is the system clock frequency set by the selected system clock source.

The register values required for standard baud rates are shown in Table 45 for a typical system clock set to 26 MHz. The

table also gives the difference in actual baud rate to standard baud rate value as a percentage error.

The maximum baud rate for UART mode is  $F/16$  when `BAUD_E` is 16 and `BAUD_M` is 0, and where  $F$  is the system clock frequency.

The maximum generated SPI clock frequency in master SPI mode is  $F/2$  when `BAUD_E` is 19 and `BAUD_M` is 0, and where  $F$  is the system clock frequency. Setting higher clock frequencies than this will give erroneous results.

The maximum SPI bit rate supported in slave mode is  $F/8$ .

Baud rate (bps)	UxBAUD.BAUD_M	UxGCR.BAUD_E	Error (%)
2400	131	6	0.04
4800	131	7	0.04
9600	131	8	0.04
14400	34	9	0.13
19200	131	9	0.04
28800	34	10	0.13
38400	131	10	0.04
57600	34	11	0.13
76800	131	11	0.04
115200	34	12	0.13
230400	34	13	0.13

**Table 45: Commonly used baud rate settings for 26 MHz system clock (CC2510Fx)**

Baud rate (bps)	UxBAUD.BAUD_M	UxGCR.BAUD_E	Error (%)
2400	163	6	0.08
4800	163	7	0.08
9600	163	8	0.09
14400	59	9	0.13
19200	163	9	0.10
28800	59	10	0.14
38400	163	10	0.10
57600	59	11	0.14
76800	163	11	0.10
115200	59	12	0.14
230400	59	13	0.14

**Table 46: Commonly used baud rate settings for 24 MHz system clock (CC2511Fx)**

#### 13.13.4 USART flushing

The current operation can be aborted by setting the UxUCR.FLUSH register bit. This event will immediately stop the current operation and clear all data buffers.

#### 13.13.5 USART Interrupts

Each USART has two interrupts. These are the RX complete interrupt (URXx) and the TX complete interrupt (UTXx).

The USART interrupt enable bits are found in the IEN0 and IEN2 registers. The interrupt flags are located in the TCON and IRCON2 registers. Refer to section 12.7 on page 49 for details of these registers. The interrupt enables and flags are summarized below.

Interrupt enables:

- USART0 RX : IEN0.URX0IE
- USART1 RX : IEN0.URX1IE

- USART0 TX : IEN2.UTX0IE
- USART1 TX : IEN2.UTX1IE

Interrupt flags:

- USART0 RX : TCON.URX0
- USART1 RX : TCON.URX1
- USART0 TX : IRCON2.UTX0
- USART1 TX : IRCON2.UTX1

### 13.13.6 USART DMA Triggers

There are two DMA triggers associated with each USART. The DMA triggers are activated by RX complete and TX complete events i.e. the same events as the USART interrupt requests. A DMA channel can be configured using a USART Receive/Transmit buffer, UxDBUF, as source or destination address.

Refer to Table 42 on page 90 for an overview of the DMA triggers.

### 13.13.7 USART Registers

The registers for the USART are described in this section. For each USART there are five registers consisting of the following (x refers to USART number i.e. 0 or 1):

- UxCSR USART x Control and Status
- UxUCR USART x UART Control
- UxGCR USART x Generic Control
- UxDBUF USART x Receive/Transmit data buffer
- UxBAUD USART x Baud Rate Control

## U0CSR (0x86) – USART 0 Control and Status

Bit	Name	Reset	R/W	Description
7	MODE	0	R/W	USART mode select 0 SPI mode 1 UART mode
6	RE	0	R/W	UART receiver enable 0 Receiver disabled 1 Receiver enabled
5	SLAVE	0	R/W	SPI master or slave mode select 0 SPI master 1 SPI slave
4	FE	0	R/W0	UART framing error status 0 No framing error detected 1 Byte received with incorrect stop bit level
3	ERR	0	R/W0	UART parity error status 0 No parity error detected 1 Byte received with parity error
2	RX_BYTE	0	R/W0	Receive byte status 0 No byte received 1 Received byte ready
1	TX_BYTE	0	R/W0	Transmit byte status 0 Byte not transmitted 1 Last byte written to Data Buffer register transmitted
0	ACTIVE	0	R	USART transmit/receive active status 0 USART idle 1 USART busy in transmit or receive mode



## U0UCR (0xC4) – USART 0 UART Control

Bit	Name	Reset	R/W	Description
7	FLUSH	0	R0/W1	Flush unit. When set, this event will immediately stop the current operation and return the unit to idle state.
6	–	0	R/W	Reserved. Must be written as 0.
5	D9	0	R/W	UART data bit 9 contents. This value is used when 9 bit transfer is enabled. When parity is disabled the value written to D9 is transmitted as the bit 9 when 9 bit data is enabled.  If parity is enabled then this bit sets the parity level as follows. 0 Even parity 1 Odd parity
4	BIT9	0	R/W	UART 9-bit data enable. When this bit is 1, data is 9 bits and the contents of data bit 9 is given by D9 and PARITY.  0 8 bits transfer 1 9 bits transfer
3	PARITY	0	R/W	UART parity enable.  0 Parity disabled 1 Parity enabled
2	SPB	0	R/W	UART number of stop bits. Selects the number of stop bits to transmit  0 1 stop bit 1 2 stop bits
1	STOP	1	R/W	UART stop bit level  0 Low stop bit 1 High stop bit
0	START	0	R/W	UART start bit level. The polarity of the idle line is assumed to be the opposite of the selected start bit level.  0 Low start bit 1 High start bit

**U0GCR (0xC5) – USART 0 Generic Control**

Bit	Name	Reset	R/W	Description
7	CPOL	0	R/W	SPI clock polarity 0 Negative clock polarity 1 Positive clock polarity
6	CPHA	0	R/W	SPI clock phase 0 Data is output on <i>MOSI</i> when <i>SCK</i> goes from <b>CPOL</b> inverted to <b>CPOL</b> , and data input is sampled on <i>MISO</i> when <i>SCK</i> goes from <b>CPOL</b> to <b>CPOL</b> inverted. 1 Data is output on <i>MOSI</i> when <i>SCK</i> goes from <b>CPOL</b> to <b>CPOL</b> inverted, and data input is sampled on <i>MISO</i> when <i>SCK</i> goes from <b>CPOL</b> inverted to <b>CPOL</b> .
5	ORDER	0	R/W	Bit order for transfers 0 LSB first 1 MSB first
4:0	BAUD_E[4:0]	0x00	R/W	Baud rate exponent value. <b>BAUD_E</b> along with <b>BAUD_M</b> decides the UART baud rate and the SPI master <i>SCK</i> clock frequency

**U0DBUF (0xC1) – USART 0 Receive/Transmit Data Buffer**

Bit	Name	Reset	R/W	Description
7:0	DATA[7:0]	0x00	R/W	USART receive and transmit data. When writing this register the data written is written to the internal transmit data register. When reading this register, the data from the internal read data register is read.

**U0BAUD (0xC2) – USART 0 Baud Rate Control**

Bit	Name	Reset	R/W	Description
7:0	BAUD_M[7:0]	0x00	R/W	Baud rate mantissa value. <b>BAUD_E</b> along with <b>BAUD_M</b> decides the UART baud rate and the SPI master <i>SCK</i> clock frequency

**U1CSR (0xF8) – USART 1 Control and Status**

Bit	Name	Reset	R/W	Description
7	MODE	0	R/W	USART mode select 0 SPI mode 1 UART mode
6	RE	0	R/W	UART receiver enable 0 Receiver disabled 1 Receiver enabled
5	SLAVE	0	R/W	SPI master or slave mode select 0 SPI master 1 SPI slave
4	FE	0	R/W0	UART framing error status 0 No framing error detected 1 Byte received with incorrect stop bit level
3	ERR	0	R/W0	UART parity error status 0 No parity error detected 1 Byte received with parity error
2	RX_BYTE	0	R/W0	Receive byte status 0 No byte received 1 Received byte ready
1	TX_BYTE	0	R/W0	Transmit byte status 0 Byte not transmitted 1 Last byte written to Data Buffer register transmitted
0	ACTIVE	0	R	USART transmit/receive active status 0 USART idle 1 USART busy in transmit or receive mode

**U1UCR (0xFB) – USART 1 UART Control**

Bit	Name	Reset	R/W	Description
7	FLUSH	0	R0/W1	Flush unit. When set, this event will immediately stop the current operation and return the unit to idle state.
6	–	0	R/W	Reserved. Must be written as 0.
5	D9	0	R/W	UART data bit 9 contents. This value is used 9 bit transfer is enabled. When parity is disabled the value written to D9 is transmitted as the bit 9 when 9 bit data is enabled.  If parity is enabled then this bit sets the parity level as follows. 0 Even parity 1 Odd parity
4	BIT9	0	R/W	UART 9-bit data enable. When this bit is 1, data is 9 bits and the contents of data bit 9 is given by D9 and PARITY.  0 8 bits transfer 1 9 bits transfer
3	PARITY	0	R/W	UART parity enable. 0 Parity disabled 1 Parity enabled
2	SPB	0	R/W	UART number of stop bits. Selects the number of stop bits to transmit 0 1 stop bit 1 2 stop bits
1	STOP	1	R/W	UART stop bit level 0 Low stop bit 1 High stop bit
0	START	0	R/W	UART start bit level. The polarity of the idle line is assumed to be the opposite of the selected start bit level. 0 Low start bit 1 High start bit

## U1GCR (0xFC) – USART 1 Generic Control

Bit	Name	Reset	R/W	Description
7	CPOL	0	R/W	SPI clock polarity 0 Negative clock polarity 1 Positive clock polarity
6	CPHA	0	R/W	SPI clock phase 0 Data is output on <i>MOSI</i> when <i>SCK</i> goes from <b>CPOL</b> inverted to <b>CPOL</b> , and data input is sampled on <i>MISO</i> when <i>SCK</i> goes from <b>CPOL</b> to <b>CPOL</b> inverted. 1 Data is output on <i>MOSI</i> when <i>SCK</i> goes from <b>CPOL</b> to <b>CPOL</b> inverted, and data input is sampled on <i>MISO</i> when <i>SCK</i> goes from <b>CPOL</b> inverted to <b>CPOL</b> .
5	ORDER	0	R/W	Bit order for transfers 0 LSB first 1 MSB first
4:0	BAUD_E[4:0]	0x00	R/W	Baud rate exponent value. <b>BAUD_E</b> along with <b>BAUD_M</b> decides the UART baud rate and the SPI master SCK clock frequency

## U1DBUF (0xF9) – USART 1 Receive/Transmit Data Buffer

Bit	Name	Reset	R/W	Description
7:0	DATA[7:0]	0x00	R/W	USART receive and transmit data. When writing this register the data written is written to the internal transmit data register. When reading this register, the data from the internal read data register is read.

## U1BAUD (0xFA) – USART 1 Baud Rate Control

Bit	Name	Reset	R/W	Description
7:0	BAUD_M[7:0]	0x00	R/W	Baud rate mantissa value. <b>BAUD_E</b> along with <b>BAUD_M</b> decides the UART baud rate and the SPI master SCK clock frequency

### 13.14 I2S

The *CC2510Fx/CC2511Fx* provides an industry standard I2S interface. The I2S interface can be used to transfer digital audio samples between the *CC2510Fx/CC2511Fx* and an external audio device, eg. audio DAC, audio DSP.

The I2S interface can be configured to operate as master or slave and may use mono as well as stereo samples. When mono mode is enabled, the same audio sample will be used for both channels. Both full and half duplex is supported and automatic  $\mu$ -Law compression and expansion can be used.

The I2S interface consists of 4 signals:

- Continuous Serial Clock (SCK)
- Word Select (WS)
- Serial Data In (RX)
- Serial Data Out (TX)

When the module is in master mode, it drives the SCK and WS lines. When the I2S interface is in slave mode, these lines are driven by an external master. The data on the serial data lines is transferred most significant bit first with one bit per SCK cycle. The WS signal selects the channel of the currently transferred word (left = 0, right = 1). It also determines the length of each word. There is a transition on the WS line one bit time before the first word is transferred and before the last bit of each word. Figure 34 shows the I2S signaling. Only a single serial data signal is shown in this figure. The SD signal could be the RX or TX signal depending on the direction of the data.

The sample in the data buffer is inverted before being sent onto the bus. Likewise, the bits received are inverted before they are loaded into the data buffer.

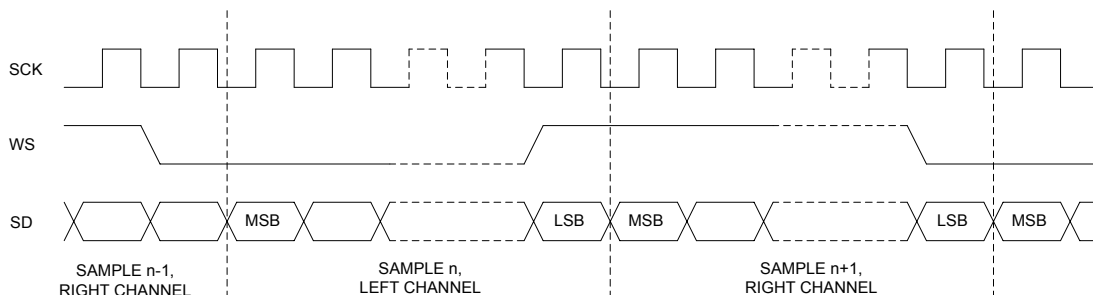

Figure 34 I2S Digital Audio Signaling

#### 13.14.1 Enabling I2S

The `I2SCFG0.ENAB` bit must be set to enable the I2S transmitter/receiver. However, when `I2SCFG0.ENAB` is not set, the I2S can still be used as a stand-alone  $\mu$ -Law compression/expansion engine. Refer to section 13.14.12 on page 162 for more details about this.

#### 13.14.2 I2S Interrupts

The I2S has two RX and TX interrupts:

- I2S RX complete interrupt (I2SRX)
- I2S TX complete interrupt (I2STX)

The I2S interrupt enable bits are found in the `I2SCFG0` register. The interrupt flags are located in the `I2SSTAT` register. The interrupt enables and flags are summarized below.

Interrupt enables:

- I2S RX: `I2SCFG0.RXIEN`
- I2S TX: `I2SCFG0.TXIEN`

Interrupt flags:

- I2S RX: `I2SSTAT.RXIRQ`
- I2S TX: `I2SSTAT.TXIRQ`

A TX interrupt is generated when the internal TX buffer is empty and the I2S

fetches the new data previously written to the I2SDATH:I2SDATL registers. The TX interrupt flag, I2SSTAT.TXIRQ, is cleared when I2SDATH register is written.

An RX interrupt is generated when the internal RX buffer is full and the contents of the RX buffer is copied to the pair of internal data registers that can be read from the I2SDATH:I2SDATL registers. The RX interrupt flag, I2SSTAT.TXIRQ, is cleared when the I2SDATH register is read.

Notice that interrupts will also be generated if the corresponding RXIRQ or TXIRQ flags are set from software.

The I2S shares interrupt vector with USART 1. Refer to section 12.7 on page 49 for more details about interrupts.

#### 13.14.3 I2S DMA Triggers

There are two DMA triggers associated with the I2S interface. The DMA triggers are activated by RX complete and TX complete events, i.e. the same events as the I2S interrupt requests. The DMA triggers are not masked by the interrupt enable bits, I2SCFG0.RXIEN and I2SCFG0.TXIEN. A DMA channel thus can be configured using the I2S receive/transmit data registers, I2SDATH:I2SDATL, as source or destination address and use the I2S DMA triggers.

Notice that I2SRX / ADC\_CH6 and I2STX / ADC\_CH7 DMA trigger pairs use the same DMA trigger numbers. Thus, only one of I2SRX and ADC\_CH6 and one of I2STX and ADC\_CH7 can be used simultaneously. On the **CC2511Fx** ADC channels 7 and 8 cannot be used since P0\_6 and P0\_7 I/O pins are not available.

Refer to Table 42 on page 90 for an overview of the DMA triggers.

#### 13.14.4 Underflow/Overflow

If the I2S attempts to read from the internal TX buffer when it is empty, an underflow condition occurs. The I2S will then continue to read from the data in the TX buffer, and the TXUNF flag of the I2SSTAT register will be set.

If the I2S attempts to write to the internal RX buffer while it is full, an overflow

condition occurs. The contents of the RX buffer will be overwritten and the RXOVF flag of the I2SSTAT register will be set.

Thus, when debugging an application, software may check for underflow/overflow when an interrupt is generated or when the application completes. The TXUNF/RXOVF flags should be cleared in software.

#### 13.14.5 Writing a word (TX)

When each sample fits into a single byte or  $\mu$ -Law compressed samples (always 8 bits) are written, i.e.  $\mu$ -Law expansion is enabled, only the I2SDATH register needs to be written.

When each sample is more than 8 bits the low byte must be written to the I2SDATL register before the high byte is written to the I2SDATH register.

Thus, writing the I2SDATH register signifies the completion of the write operation.

When the I2S is configured to send stereo, i.e. I2SCFG0.TXMONO is 0, the I2SSTAT.TXLR flag can be used to determine whether the left- or right-channel sample is to be written to the data registers.

#### 13.14.6 Reading a word (RX)

If each sample fits into a single byte or  $\mu$ -Law compression is enabled, only the I2SDATH register needs to be read.

When each sample is more than 8 bits the low byte must be read from the I2SDATL register before the high byte is being read from the I2SDATH register.

Thus, reading from the I2SDATH register signifies the completion of the read operation.

When the I2S is configured to receive stereo, i.e. I2SCFG0.RXMONO is 0, the I2SSTAT.RXLR flag can be used to determine whether the sample currently in the data registers is a left- or right-channel sample.

#### 13.14.7 Full vs. half duplex

The I2S interface supports full duplex and half duplex operation.

In full duplex both the RX and TX lines will be used. Both the I2SCFG0.TXIEN and I2SCFG0.RXIEN interrupt enable bits must be set if interrupts are used and both the DMA triggers I2STX and I2SRX may be used.

When half duplex is used only one of the RX and TX lines are typically connected. Only the appropriate interrupt flag should be set and only one of the DMA triggers should be used.

### 13.14.8 Master Mode

The I2S is configured as a master device by setting I2SCFG0.MASTER to 1. In master mode the SCK and WS signals are generated by the I2S.

#### 13.14.8.1 Clock Generation

When the I2S is configured as master, the frequency of the SCK clock signal must be set to match the sample rate. The clock frequency must be set before master mode is enabled.

SCK is generated by dividing the system clock using a fractional clock divider. The amount of division is given by the 15-bit numerator, NUM and 9-bit denominator, DENOM as shown in the following formula:

$$F_{sck} = \frac{F_{clk}}{2 \left( \frac{NUM}{DENOM} \right)}$$

$$\text{where } \frac{NUM}{DENOM} > 3.35$$

Where  $F_{clk}$  is the system clock frequency and  $F_{sck}$  is the I2S SCK sample clock frequency.

The numerator and denominator are set by writing to the clock configuration registers I2SCLKF0, I2SCLKF1 and I2SCLKF2.

Please note that to stay within the timing requirements of the I2S specification [3], a minimum value of 3.35 should be used for the (NUM / DENOM) fraction.

The fractional divider is made such that most normal sample rates should be supported for most normal word sizes with a 24 MHz system clock frequency (CC2511Fx). Examples of supported configurations for a 24 MHz CLK is given in Table 47. Table 48 shows the configuration values for a 26 MHz system clock frequency. Notice that the generated I2S frequency is not exact for the 44.1 kHz, 16 bits word size configuration at 26 MHz. The numbers are calculated using the following formulas, where  $F_s$  is the sample rate and  $W$  is the word size:

$$F_s = \frac{F_{sck}}{2 * W}$$

$$CLKDIV = \frac{NUM}{DENOM} = \frac{F_{clk}}{4 * W * F_s}$$

F <sub>sck</sub> (kHz)	Word Size (W)	CLKDIV	I2SCLKF2	I2SCLKF1	I2SCLKF0	Exact
8	8	93.75	0x01	0x77	0x04	yes
8	16	46.875	0x01	0x77	0x08	yes
44.1	16	8.503401	0x04	0xE2	0x93	yes
48	16	7.8125	0x00	0x7D	0x10	yes

Table 47 Example I2S Clock Configurations (CC2511Fx, 24 MHz)

F <sub>sck</sub> (kHz)	Word Size (W)	CLKDIV	I2SCLKF2	I2SCLKF1	I2SCLKF0	Exact
8	8	101.5625	0x06	0x59	0x10	yes
8	16	50.78125	0x06	0x59	0x20	yes



44.1	16	9.21201	0x8A	0x2F	0x1B	no
48	16	8.46354	0x06	0x59	0xC0	yes

Table 48 Example I2S Clock Configurations (CC2510Fx, 26 MHz)

### 13.14.8.2 Word Size

The word size must be set before master mode is enabled. The word size is the number of bits used for each sample and can be set to a value between 1 and 33. To set the word size, write word size – 1 to the `I2SCFG.WORDS[4:0]` bits. Setting the word size to a value of 17 or more causes the I2S to pad each word with 0's in the least significant bits since the data registers provide maximum 16 bits. This feature allows samples to be sent to an I2S device that takes a higher resolution than 16 bits.

If the size of received samples exceeds 16 bits, only the 16 most significant bits will be put in the data registers and the remaining low order bits will be discarded.

### 13.14.9 Slave Mode

The I2S is configured as a slave device by setting `I2SCFG0.MASTER` to 0. When in slave mode the SCK and WS signals are generated by an external I2S master and are inputs to the I2S interface.

#### 13.14.9.1 Word Size

When the I2S operates in slave mode, the word size is determined by the master that generates the WS signal.

The I2S will provide bits from the internal 16-bit buffer until the buffer is empty. If the buffer becomes empty and the master still requests more bits, the I2S will send 0's (low order bits).

If more than 16 bits are being received, the low order bits are discarded.

#### 13.14.10 Mono

The I2S also supports mono audio samples.

To receive mono samples, set the `I2SCFG0.RXMONO` bit to 1. Words from the right channel will then not be read into the data registers. This feature is included because some mono devices repeat their

audio data in both channels and the left channel is the default mono channel.

To send mono samples, set the `I2SCFG0.TXMONO` bit to 1. Each word will then be repeated in both channels before a new word is fetched from the data registers. This is to enable sending a mono audio signal to a stereo audio sink device.

#### 13.14.11 Word Counter

The I2S contains a 10-bit word counter that counts the number of transitions on the WS line since the last time the word counter was cleared.

Triggers are used to clear the word counter. When a trigger occurs or software writes any value to the `I2SWCNT` register, the current value of the word counter is copied into the `WCNT[9:0]` field in the `I2SWCNT/I2SSTAT` registers and the word counter is cleared.

Three triggers can be used to copy/clear the word counter.

- USB SOF: USB Start of Frame. Occurs every ms.
- T1\_CH0: Timer 1, compare, channel 0
- IOC\_1: IO pin input transition

When the I2S is configured not to use any trigger, the word counter can only be copied/cleared from software.

The `I2SCFG1.TRIGNUM[1:0]` field selects the trigger source.

The word counter will saturate if it reaches its maximum value. Software should configure the trigger-interval and sample-rate to ensure this never happens.

**CC2511Fx:** The word counter is typically used to calculate the average sample rate over a long period of time (e.g. 1 second) needed by adaptive isochronous USB endpoints. The USB SOF event must then be used as trigger.

13.14.12 *μ-Law compression and expansion*

The I2S interface can be configured to perform  $\mu$ -Law compression and expansion.  $\mu$ -Law compression is enabled by setting the I2SCFG0.ULAWC bit to 1 and  $\mu$ -Law expansion is enabled by setting the I2SCFG0.ULAWE bit to 1.

When the I2S interface is enabled, i.e. the I2SCFG0.ENAB bit is 1, and  $\mu$ -Law expansion is enabled, every byte of  $\mu$ -Law compressed data written to the I2SDATH register is expanded to a 16-bit sample before being transmitted. When the I2S interface is enabled and  $\mu$ -Law compression is enabled each sample received is compressed to an 8-bit  $\mu$ -Law sample and put in the I2SDATH register.

When the I2S interface is disabled, i.e. the I2SCFG0.ENAB bit is 0, it can still be used to perform  $\mu$ -Law compression/expansion for other resources in the system. To perform an expansion, the I2SCFG0.ULAWE must be set and the I2SCFG0.ULAWC bit must be cleared. Then write a byte of compressed data to the I2SDATH register. The expansion takes one clock cycle to perform, and then the result can

be read from the I2SDATH:I2SDATL registers.

To perform a compression the I2SCFG0.ULAWC bit must be set and the I2SCFG0.ULAWE bit must be cleared. To start the compression, write a uncompressed 16-bit sample to the I2SDATH:I2SDATL registers. The compression takes one clock cycle to perform, and then the result can be read from the I2SDATH register.

Only one of the flags I2SCFG0.ULAWC and I2SCFG0.ULAWE should be set when the I2S interface is used without the I2SCFG0.ENAB bit is set.

13.14.13 *I2S Registers*

This section describes all I2S registers used for control and status for the I2S. The USB registers reside in XDATA memory space in the region 0xDF40-0xDF48. Table 49 gives an overview of register addresses while the remaining tables in this section describe each register. Notice that the reset values for the registers reflect a configuration with 16-bit stereo samples and 44.1 kHz sample rate. The I2S is not enabled at reset.

XDATA Address	Register	Description
0xDF40	I2SCFG0	I2S Configuration Register 0
0xDF41	I2SCFG1	I2S Configuration Register 1
0xDF42	I2SDATL	I2S Data Low Byte
0xDF43	I2SDATH	I2S Data High Byte
0xDF44	I2SWCNT	I2S Word Count Register
0xDF45	I2SSTAT	I2S Status Register
0xDF46	I2SCLKF0	I2S Clock Configuration Register 0
0xDF47	I2SCLKF1	I2S Clock Configuration Register 1
0xDF48	I2SCLKF2	I2S Clock Configuration Register 2

Table 49 Overview of I2S Registers

0xDF40: I2SCFG0 – I2S Configuration Register 0

Bit	Field Name	Reset	R/W	Description
7	TXIEN	0	R/W	Transmit interrupt enable.
			0	interrupts are disabled

Bit	Field Name	Reset	R/W	Description
				1   interrupts are enabled
6	RXIEN	0	R/W	Receive interrupt enable.
				0   interrupts are disabled
				1   interrupts are enabled
5	ULAWE	0	R/W	μ-Law expansion enable bit. Set to enable expansion of data to transmit when ENAB is set, or to expand data written to I2SDATH when ENAB is cleared.
4	ULAWC	0	R/W	μ-Law compression enable bit. Set to enable compression of data received when ENAB is set, or to compress data written to I2SDATH:I2SDATL when ENAB is cleared.
3	TXMONO	0	R/W	TX mono enable. If this bit is set, each sample of audio data will be repeated in both channels before a new sample is fetched. This is to enable sending a mono signal to a stereo audio sink device.
2	RXMONO	0	R/W	RX mono enable. If this bit is set, data from the right channel will be discarded, i.e. not be read into the data registers. This feature is included because some mono devices repeat their audio data in both channels and left is the default mono channel.
1	MASTER	0	R/W	The master bit indicates if the I2S should generate the CLK and WS signals or if it should read them from the pads.
0	ENAB	0	R/W	The bit enables the I2S interface.  Notice that this bit must not be set if the I2S is to be used as a μ-Law compression/expansion unit.

**0xDF41: I2SCFG1 – I2S Configuration Register 1**

Bit	Field Name	Reset	R/W	Description
7:3	WORDS[ 4 : 0 ]	0x0F	R/W	This field gives the word size – 1. The word size is the bit-length of one sample for one channel. Used to generate the WS signal when in master mode.  Reset value 0x0F give 15 + 1 = 16 bit samples.
2:1	TRIGNUM[ 1 : 0 ]	00	R/W	Word counter copy and clear trigger to use. When zero, the word counter can only be cleared by software.  0 – No trigger 1 – USB SOF 2 – IOC_1 3 – T1_CH0
0	IOLOC	0	R/W	The pin locations for the I2S signals. This bit selects between the two alternative pin mapping alternatives. Refer to Table 41 for an overview of pin locations.  0 – Alt. 1 in Table 41 is used 1 – Alt. 2 in Table 41 is used

**0xDF42: I2SDATL – I2S Data Low Byte**

Bit	Field Name	Reset	R/W	Description
-----	------------	-------	-----	-------------

Bit	Field Name	Reset	R/W	Description
7:0	I2SDAT[7:0]	0x00	R/W	Data register low byte.  If the I2SDATL register is not written between two writes of the I2SDATH register, the low byte of the TX register will be cleared.

### 0xDF43: I2SDATH – I2S Data High Byte

Bit	Field Name	Reset	R/W	Description
7:0	I2SDAT[15:8]	0x00	R/W	Data register high byte.  When this register is read, the RXIRQ bit of the I2SSTAT register is cleared and the RX buffer is considered empty. When this register is written, the TXIRQ bit of the I2SSTAT register is cleared and the TX buffer is considered full.

### 0xDF44: I2SWCNT – I2S Word Count Register

Bit	Field Name	Reset	R/W	Description
7:0	WCNT[7:0]	0x00	R/W	This register contains the 8 low order bits of the 10-bit internal word counter at the time the last trigger specified by I2SCFG1.TRIGNUM occurred. If this register is written (any value), the value of the internal word counter is copied into this register and the internal word counter is cleared.  Refer to section 13.14.11 for details about how to use this register.

### 0xDF45: I2SSTAT – I2S Status Register

Bit	Field Name	Reset	R/W	Description
7	TXUNF	0	R/W	Tx buffer underflow. This bit must be cleared by software.
6	RXOVF	0	R/W	Rx buffer overflow. This bit must be cleared by software.
5	TXLR	0	R	Left (=0) or right (=1) channel should be placed in transmit buffer.
4	RXLR	0	R	Left (=0) or right (=1) channel currently in receive buffer.
3	TXIRQ	0	R/W H0	Interrupt flag indicating that a tx interrupt request has not been serviced. This bit is cleared by hardware when the I2SDATH register is written.
2	RXIRQ	0	R/W H0	Interrupt flag indicating that an rx interrupt request has not been serviced. This is cleared by hardware when the I2SDATH register is read.
1:0	WCNT[9:8]	00	R	Upper 2 bits of the copy of the 10-bit internal word counter at the time of the last trigger.

### 0xDF46: I2SCLKF0 – I2S Clock Configuration Register 0

Bit	Field Name	Reset	R/W	Description
7:0	DENOM[7:0]	0x93	R/W	The clock division denominator low bits

### 0xDF47: I2SCLKF1 – I2S Clock Configuration Register 1

Bit	Field Name	Reset	R/W	Description
7:0	NUM[7:0]	0xE2	R/W	Clock division numerator low bits

### 0xDF48: I2SCLKF2 – I2S Clock Configuration Register 2

Bit	Field Name	Reset	R/W	Description
7	DENOM[8]	0	R/W	Clock division denominator high bits
6:0	NUM[14:8]	0x04	R/W	Clock division numerator high bits.

### 13.15 USB Controller

*Note: The USB controller is only available on the CC2511Fx.*

The **CC2511Fx** contains a Full-Speed USB 2.0 compatible function controller for serial communication with a PC or other equipment with USB host functionality.

*Note: This section will focus on describing the functionality of the USB Controller. Thus, it is assumed that the reader has a good understanding of USB and is familiar with the terms and concepts used. Refer to the Universal Serial Bus Specification for details.*

*Standard USB nomenclature is used regarding IN and OUT. I.e, IN is always into the host (PC) and OUT is out of the host (into CC2511Fx)*

The USB Controller monitors the USB bus for relevant activity and handles packet transfer. The USB function will always operate as a slave on the USB bus. A packet can therefore only be sent (or received) when the USB host sends a request in the form of a token.

Appropriate response to USB interrupts and loading/unloading of packets into/from endpoint FIFOs is the responsibility of the

firmware. The firmware must be able to reply correctly to all standard requests from the USB host and work according to the protocol implemented in the driver on the PC.

The USB Controller has the following features:

- Full-Speed operation (up to 12 Mbps)
- 5 endpoints (in addition to endpoint 0) that can be used as IN, OUT or IN/OUT and can be configured as Bulk, Interrupt or Isochronous.
- 1 KB SRAM FIFO available for storing USB packets
- Endpoints supporting packet sizes from 8 – 512 bytes
- Support for double buffering of USB packets

Figure 35 shows a block diagram of the USB Controller. The USB PHY is the physical interface with input and output drivers. The USB SIE is the Serial Interface Engine which controls the packet transfer to/from the endpoints. The USB Controller is connected to the rest of the system through the Memory Arbiter.

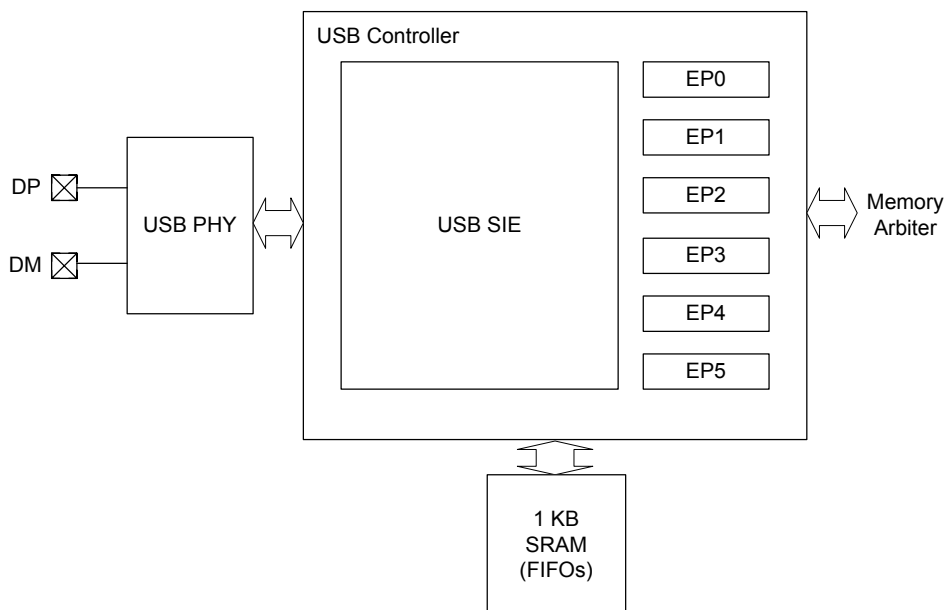

Figure 35: USB Controller block diagram

### 13.15.1 USB Registers

The operation of the USB is configured through a set of USB registers. These USB registers are mapped to XDATA memory space as shown in Figure 10 on page 36.

In addition to configuration registers, the USB registers also provide status information.

The USB registers control/status bits are referred to where appropriate in the following sections while section 13.15.11 on page 175 gives a full description of all USB registers.

### 13.15.2 48 MHz Clock

A 48 MHz external crystal must be used for the USB Controller to operate correctly. This 48 MHz clock is divided by two internally to generate the system clock at 24 MHz. It is important that the crystal oscillator is stable before the USB Controller is accessed. See 13.10.3 for details on how to set up the crystal oscillator.

### 13.15.3 USB Enable

The USB Controller must be enabled before it is used. This is performed by setting the `SLEEP_USB_EN` bit to 1. Setting `SLEEP_USB_EN` to 0 will reset the USB Controller.

### 13.15.4 USB Interrupts

There are 3 interrupt flag registers with associated interrupt enable mask registers. The `USBCIF` register contains flags for common USB interrupts. The `USBIIF` register has interrupt flags for endpoint 0 and all the IN endpoints. `USBOIF` has interrupt flags for all OUT endpoints. All interrupts except SOF and and SUSPEND are initially enabled after reset.

When the interrupt flag of an enabled interrupt is set, the USB interrupt is asserted. This interrupts the 8051 CPU which will start executing the interrupt service routine if there is no higher priority interrupts pending. The USB Controller uses interrupt number 6 for USB interrupts. This is the same interrupt number used for Port 2 inputs. Thus, the

interrupt routine must also handle Port 2 interrupts if they are used. The interrupt routine should read all the interrupt flag registers and take action depending on the status of the flags. The interrupt flag registers will be cleared when they are read. The interrupt flags must therefore be saved in memory (typically in a local variable on the stack) to be used in multiple operations.

To enable USB interrupts `IEN2.P2IE` must be set to 1. It is important that the `P2IFG` register is cleared and then the `IRCON2.P2IF` bit is cleared at the end of the USB interrupt service routine after the interrupt flags have been read. This allows new USB/P2 interrupts to be detected.

Refer to Table 33 for a complete list of interrupts and section 12.7 for more details about interrupts.

#### 13.15.4.1 USB Resume Interrupt

Bit 7 of Port 0 is used to wake up the **CC2511Fx** from PM1/suspend when resume signaling has been detected on the USB bus. `IEN1.P0IE` must therefore be set to 1 to enable P0 interrupts. `PICTL.P0IENH` must be set to 1 to enable interrupts on P0[7:4] and `PICTL.P0ICON` must be 0 to enable interrupts on rising edge. The P0 interrupt routine should check bit 7 of `P0IFG` and resume if this bit is set. Notice that bit 7 and bit 6 of Port 0 are not available as external ports on **CC2511Fx**. If PM1 is entered from within an interrupt routine (typically the USB/P2 interrupt routine) due to a suspend interrupt, it is important that the priority of the P0 interrupt is set higher than the interrupt that entered PM1. See section 13.15.9 for more details about suspend and resume.

#### 13.15.5 Endpoint 0

Endpoint 0 (EP0) is a bi-directional control endpoint. A USB function is required to implement a control endpoint at endpoint 0. During the enumeration phase all communication is performed across this endpoint. Before the `USBADDR` register has been set (to a value other than 0), the USB Controller will only be able to communicate through endpoint 0. Setting the `USBADDR` register will bring the USB function out of the Default state in the enumeration phase and into the

Addressed state. All configured endpoints will then be available for the application.

The EP0 FIFO is only used as IN or OUT at a time. The maximum packet size for endpoint 0 is fixed at 32 bytes. Double buffering is not provided for endpoint 0.

Endpoint 0 is controlled through the USB\_CS0 register. The USB\_INDEX register must be set to 0. The USB\_CNT0 register contains the number of bytes received.

#### 13.15.5.1 Interrupts

Endpoint 0 will generate an interrupt on any of the following events:

- A data packet has been received.
- A data packet that was loaded into the EP0 FIFO has been sent to the USB host.
- An IN transaction has been completed.
- The USB\_CS0.SENT\_STALL bit has been set.
- The USB\_CS0.SETUP\_END bit has been set.

#### 13.15.5.2 Error conditions

When a protocol error occurs the USB Controller sends a STALL handshake. The USB\_CS0.SENT\_STALL bit is set and an interrupt is generated. A protocol error can be any of the following:

- An OUT token is received after USB\_CS0.DATA\_END has been set to complete the OUT Data stage. Thus, the host tries to send more data than expected.
- An IN token is received after USB\_CS0.DATA\_END has been set to complete the IN Data stage. Thus, the host tries to receive more data than expected.
- The USB host tries to send a packet that exceeds the maximum packet size during the OUT Data stage.
- The size of the DATA1 packet received during the Status stage is not 0.

The firmware can also terminate the current transaction by setting the USB\_CS0.SEND\_STALL bit. The USB Controller will then send STALL handshake in response to requests from the USB host.

When firmware receives an EP0 interrupt and finds that the USB\_CS0.SENT\_STALL bit is set it should clear the USB\_CS0.SENT\_STALL bit and abort the current transfer.

If EP0 receives an unexpected token during the Data stage USB\_CS0.SETUP\_END will be set and an EP0 interrupt will be generated. EP0 will then switch to the IDLE state. Firmware should then set the USB\_CS0.CLR\_SETUP\_END bit and abort the current transfer. If USB\_CS0.OUTPKT\_RDY is set, this indicates that another SETUP packet has been received that firmware should process.

#### 13.15.5.3 SETUP Transactions (IDLE state)

The first transaction in a control transfer consists of a SETUP packet, sent from the host. A SETUP packet is always 8 bytes and contains a pre-defined set of fields. This is the Setup stage of a control transfer and EP0 will be in the IDLE state. Consult the USB 2.0 Specification [2] for details about this. The USB Controller will reject the first packet if the size of the packet is not 8 bytes. Also, the USB Controller will examine the contents of the SETUP packet to determine whether the Data stage will consist of IN or OUT transactions and EP 0 will switch state to TX or RX when the USB\_CS0.CLR\_OUTPKT\_RDY bit is set if USB\_CS0.DATA\_END is not set.

When a packet is received, the USB\_CS0.OUTPKT\_RDY bit will be set and an EP0 interrupt is generated. Firmware should perform the following when a SETUP packet has been received:

1. Unload the SETUP packet from the EP0 FIFO
2. Examine the contents and perform the appropriate operations



3. Set the `USBCS0.CLR_OUTPKT_RDY` bit. This denotes the end of the Setup stage. If the control transfer has no Data stage, the `USBCS0.DATA_END` bit must also be set. If there is no Data stage, the USB Controller will stay in the IDLE state.

#### 13.15.5.4 IN Transactions (TX state)

If the control transfer requires data to be sent to the host, the Setup Stage will be followed by one or more IN transactions (a Data IN stage). In this case the USB Controller will be in TX state and only accept IN tokens. If more than 32 bytes (maximum packet size) is to be sent, the data must be split into a number of 32 byte packets followed by a residual packet. If the number of bytes to send is divisible by 32, the residual packet will be a zero length data packet. Thus, a packet size less than 32 bytes denotes the end of the transfer.

Firmware should load the EP0 FIFO with the first data packet and set the `USBCS0.INPKT_RDY` bit as soon as possible after the `USBCS0.CLR_OUTPKT_RDY` bit has been set. The `USBCS0.INPKT_RDY` bit will be cleared and an EP0 interrupt will be generated when the data packet has been sent. Firmware might then load more data packets as necessary. An EP0 interrupt will be generated for each packet sent. Firmware must set `USBCS0.DATA_END` in addition to `USBCS0.INPKT_RDY` when the last data packet has been loaded. This will start the Status stage of the control transfer.

EP0 will switch to the IDLE state when the Status stage has completed. The Status stage may fail if the `USBCS0.SEND_STALL` bit is set. The `USBCS0.SENT_STALL` bit will then be set and an interrupt will be generated as explained in section 13.15.5.2.

If `USBCS0.INPKT_RDY` is not set when receiving an IN token, the USB Controller will reply with a NAK to indicate that the endpoint is working, but temporarily has no data to send.

#### 13.15.5.5 OUT Transactions (RX state)

If the control transfer requires data to be received from the host, the Setup stage will be followed by one or more OUT transactions (a Data OUT stage). In this case the USB Controller will be in RX state and only accept OUT tokens. If more than 32 bytes (maximum packet size) is to be received, the data must be split into a number of 32 byte packets followed by a residual packet. If the number of bytes is divisible by 32, the residual packet will be a zero length data packet. Thus, a packet size less than 32 bytes denotes the end of the transfer.

The `USBCS0.OUTPKT_RDY` bit will be set and an EP0 interrupt will be generated when a data packet has been received. The firmware should set `USBCS0.CLR_OUTPKT_RDY` when the data packet has been unloaded from the EP0 FIFO. When the last data packet has been received (packet size less than 32) firmware should also set `USBCS0.DATA_END`. This will start the Status stage of the control transfer.

EP0 will switch to the IDLE state when the Status stage has completed. The Status stage may fail if the DATA1 packet received is not a zero length data packet or the `USBCS0.SEND_STALL` bit is set. The `USBCS0.SENT_STALL` bit will then be set and an interrupt will be generated as explained in section 13.15.5.2.

#### 13.15.6 Endpoints 1 – 5

Each endpoint can be used as a IN only, OUT only or IN/OUT. For a IN/OUT endpoint there are basically two endpoints, a IN and a OUT endpoint associated with the endpoint number. Configuration and control of IN endpoints is performed by accessing the `USBCSIL` and `USBCSIH` registers. The `USBCSOL` and `USBCSOH` registers are used to configure and control OUT endpoints. Each IN and OUT endpoint can be configured as a Isochronous or Bulk/Interrupt endpoint. This is done by setting the `USBCSIH.ISO` and `USBCSOH.ISO` bits. Bulk and Interrupt endpoints are handled identically by the USB Controller but will have different properties from a firmware perspective.

The USBINDEX register must have the value of the endpoint number before the Indexed Endpoint Registers are accessed.

13.15.6.1 FIFO Management

Each endpoint has a number of FIFO memory bytes available for incoming and outgoing data packets. Table 50 shows the FIFO size for endpoints 1 – 5. It is the firmware that is responsible for setting the USBMAXI and USBMAXO registers correctly for each endpoint so that no data potentially gets overwritten.

When both the IN and OUT endpoint of an endpoint number do *not* use double buffering, the sum of USBMAXI and USBMAXO must not exceed the FIFO size for the endpoint. Figure 36 a) shows how the IN and OUT FIFO memory for an endpoint is organized with single buffering. The IN FIFO grows down from the top of the endpoint memory region while the

OUT FIFO grows up from the bottom of the endpoint memory region.

When the IN or OUT endpoint of an endpoint number *use* double buffering, the sum of USBMAXI and USBMAXO must not exceed half the FIFO size for the endpoint. Figure 36 b) illustrates the IN and OUT FIFO memory for an endpoint that uses double buffering. Notice that the second OUT buffer starts from the middle of the memory region and grows upwards. The second IN buffer also starts from the middle of the memory region but grows downwards.

To configure an endpoint as IN only, set USBMAXO to 0 and to configure an endpoint as OUT only, set USBMAXI to 0.

The USBMAXO and USBMAXI registers should be 0 for unused endpoints.

EP Number	FIFO Size (in bytes)
1	32
2	64
3	128
4	256
5	512

Table 50 FIFO Sizes for EP 1 – 5

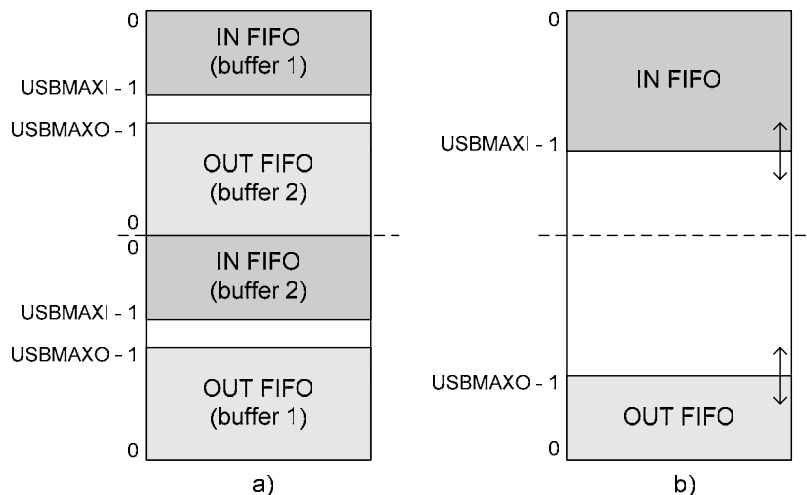

Figure 36: IN/OUT FIFOs, a) Double buffering b) Single buffering

### 13.15.6.2 Double buffering

Double buffering allows two packets to be buffered in the FIFO. This reduces retransmission and is highly recommended for isochronous endpoints which do not use retransmission. For isochronous endpoint one data packet will be sent/received every USB frame. However, the data packet may be sent/received at any time during the USB frame period. Thus, two data packets may be sent/received at a few micro seconds interval. For isochronous endpoints an incoming packet will be lost if there is no buffer available and a zero length data packet will be sent if there is no data packet ready for transmission when the USB host requests data. Double buffering is not as critical for bulk and interrupt endpoints since packets will not be lost. Double buffering, however, may improve the effective data rate for bulk endpoints.

To enable double buffering for an IN endpoint, set `USBCSIH.IN_DBL_BUF` to 1. To enable double buffering for an OUT endpoint, set `USBCSOH.OUT_DBL_BUF` to 1.

### 13.15.6.3 FIFO Access

The endpoint FIFOs are accessed by reading and writing to the registers in Table 53. Writing to a register causes the byte written to be inserted into the IN FIFO. Reading a register causes the next byte in the OUT FIFO to be extracted and the value of this byte to be returned.

When a data packet has been written to a IN FIFO the `USBCSIL.INPKT_RDY` bit must be set. If double buffering is enabled, the `USBCSIL.INPKT_RDY` bit will be cleared immediately after it has been written and another data packet can be loaded. This will not generate an interrupt, since an interrupt is only generated when a packet has been sent. When double buffering is used firmware should check the status of the `USBCSIL.PKT_PRESENT` bit before writing to the IN FIFO. If this bit is 0, two data packets can be written. Double buffered isochronous endpoints should only need to load two packets the first time the IN FIFO is loaded. After that, one packet is loaded for every USB frame. To send a zero length data packet set

`USBCSIL.INPKT_RDY` without loading a data packet into the IN FIFO.

A data packet can be read from the OUT FIFO when the `USBCSOL.OUTPKT_RDY` bit is set. An interrupt will be generated when this occurs, if enabled. The size of the data packet is kept in the `USBCNTH:USBCNTL` registers. When the data packet has been read from the OUT FIFO, the `USBCSOL.OUTPKT_RDY` bit must be cleared. If double buffering is enabled there may be two data packets in the FIFO. If another data packet is ready when the `USBCSOL.OUTPKT_RDY` bit is cleared the `USBCSOL.OUTPKT_RDY` bit will be set immediately and an interrupt will be generated to signal that a new data packet has been received. The `USBCSOL.FIFO_FULL` bit will be set when there are two data packets in the OUT FIFO.

The AutoClear feature is supported for OUT endpoints. When enabled, the `USBCSOL.OUTPKT_RDY` bit is cleared automatically when `USBMAXO` bytes have been read from the OUT FIFO. The AutoClear feature is enabled by setting the `USBCSOH.AUTOCLEAR` bit. The AutoClear feature can be used to reduce the time the data packet occupies the OUT FIFO buffer and is typically used for bulk endpoints.

A complementary AutoSet feature is also supported for IN endpoints. When enabled, the `USBCSIL.INPKT_RDY` bit is set automatically when `USBMAXI` bytes have been written to the IN FIFO. The AutoSet feature is enabled by setting the `USBCSOH.AUTOSSET` bit. The AutoSet feature can reduce the overall time it takes to send a data packet and is typically used for bulk endpoints.

### 13.15.6.4 Endpoint Interrupts

IN endpoints generate interrupts by setting the interrupt flags in the `USBIF` register in the following situations:

- A data packet has been successfully sent to the host.
- A STALL condition has been generated by the hardware.
- The IN FIFO is flushed due to the `USBCSIH.FLUSH_PACKET` bit being set.

OUT endpoints generate interrupts by setting the interrupt flags in the USBOIF register in the following situations:

- A data packet has been received. `USBCSOL.OUTPKT_RDY` has been set.
- A STALL condition has been generated by the hardware.

#### 13.15.6.5 Bulk/Interrupt IN Endpoint

Interrupt IN transfers occur at regular intervals while bulk IN transfers utilize available bandwidth not allocated to isochronous, interrupt and control transfers and can happen at any time.

Interrupt IN endpoints may set the `USBCSIH.FRC_DATA_TOG` bit. When this bit is set the data toggle bit is continuously toggled regardless of whether an ACK was received. This feature is typically used by interrupt IN endpoints that report rate feedback for isochronous endpoints.

A Bulk/Interrupt IN endpoint can be stalled by setting the `USBCSIL.SEND_STALL` bit to 1. When the endpoint is stalled the USB Controller will respond with a STALL handshake to IN tokens. The `USBCSIL.SEND_STALL` bit will then be set and an interrupt will be generated.

A bulk transfer longer than the maximum packet size is performed by splitting the transfer into a number of data packets of maximum size followed by a smaller data packet containing the remaining bytes. If the transfer length is divisible by the maximum packet size a zero length data packet is sent last. Thus, a packet with a size less than the maximum packet size denotes the end of the transfer. The AutoSet feature can be useful in this case, since many data packets will be of maximum size.

#### 13.15.6.6 Isochronous IN Endpoint

An isochronous IN endpoint is guaranteed to be able to send exactly one data packet every USB frame and is typically used to send a continuous stream of data.

If there is no data packet loaded in the IN FIFO when the USB host requests data, the USB Controller sends a zero length data packet. The `USBCSIL.UNDERRUN` bit

will be set and an interrupt will be generated.

Double buffering requires the data packet to be loaded during the frame before the packet is sent. If the first data packet is loaded before an IN token is received the data packet will be sent during the same frame the packet is loaded which violates the double buffering strategy. Thus, when double buffering is used, the `USBPOW.ISO_WAIT_SOF` bit should be set to avoid this. Setting this bit will ensure that a loaded data packet is not sent until the next SOF token has been received.

The AutoSet feature will typically not be used for isochronous endpoints since the packet size will increase or decrease from frame to frame to match the source data rate.

Notice that an isochronous endpoint cannot be stalled.

#### 13.15.6.7 Bulk/Interrupt OUT Endpoint

Interrupt OUT transfers occur at regular intervals while bulk OUT transfers utilize available bandwidth not allocated to isochronous, interrupt and control transfers and can happen at any time.

A Bulk/Interrupt OUT endpoint can be stalled by setting the `USBCSOL.SEND_STALL` bit to 1. When the endpoint is stalled the USB Controller will respond with a STALL handshake when the host is done sending the data packet. The data packet is discarded and is not placed in the OUT FIFO. The USB Controller will set the `USBCSOL.SEND_STALL` bit and generate an interrupt when the STALL handshake is sent.

As the AutoSet feature is useful for bulk IN endpoints, the AutoClear feature is useful for OUT endpoint since many packets will be of maximum size.

#### 13.15.6.8 Isochronous OUT Endpoint

An isochronous OUT endpoint is guaranteed to receive exactly one data packet every USB frame and is typically used to receive a continuous stream of data.

If there is no buffer available when a data packet is being received the

USBCSOL.OVERRUN is set and the packet data will be lost. Firmware can reduce the chance for this to happen by using double buffering and use DMA to effectively unload data packets.

An isochronous data packet in the OUT FIFO may have bit errors. The hardware will detect this condition and set USBCSOL.DATA\_ERROR. Firmware should therefore always check this bit when unloading a data packet.

The AutoClear feature will typically not be used for isochronous endpoints since the packet size will increase or decrease from frame to frame to match the source data rate.

Notice that an isochronous endpoint cannot be stalled.

13.15.7 DMA

DMA should be used to fill the IN endpoint FIFOs and empty the OUT endpoint FIFOs. Using DMA will improve read/write performance significantly compared to using the 8051 CPU. It is therefore highly recommended to use DMA unless timing is not critical or only a few bytes are to be transferred.

There are no DMA triggers for the USB Controller. Thus, DMA transfers must be

triggered by firmware. The DMA Transfer Mode should be set to block transfer.

The word size can be byte (8 bits) or word (16 bits). When word size transfer is used the ENDIAN register must be set correctly. The ENDIAN.USBRLE bit selects whether word data is read as little or big endian from OUT FIFOs and the ENDIAN.USBWLE bit selects whether word data is written as little or big endian to IN FIFOs. Writing and reading words for the different settings is shown in Figure 37 and Figure 38 respectively. Notice that the setting for these bits will be used for all endpoints. Consequently, it is not possible to have multiple DMA channels active at once that use different endianness. The ENDIAN register must be configured to use big endian for both read and write for a word size transfer to produce the same result as a byte size transfer of an even number of bytes. Refer to section 12.12 for more information about the ENDIAN register. Word size transfer is slightly more efficient than byte transfer.

Refer to section 13.2 for more information about how to use DMA.

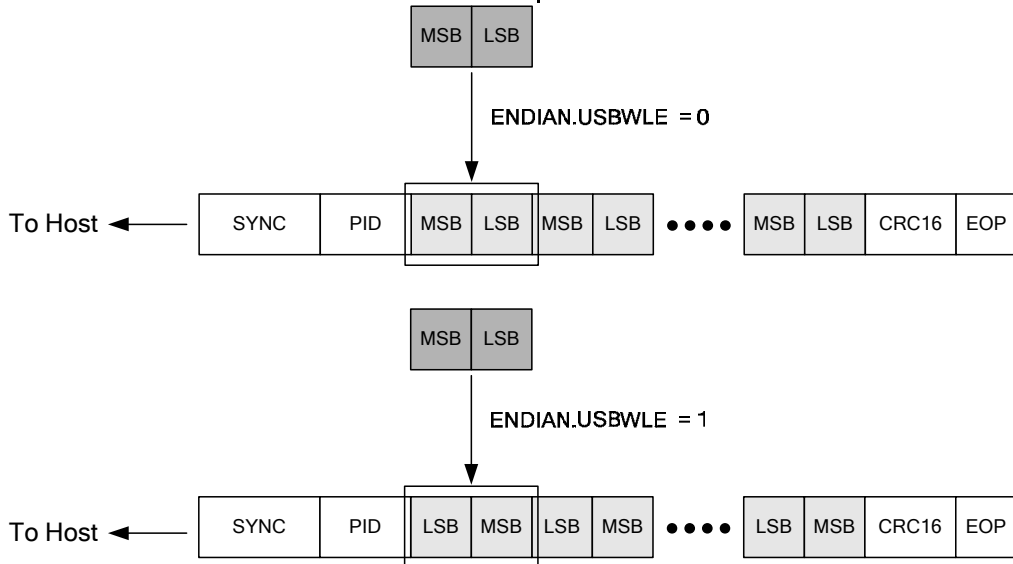

Figure 37 Writing Little/Big Endian

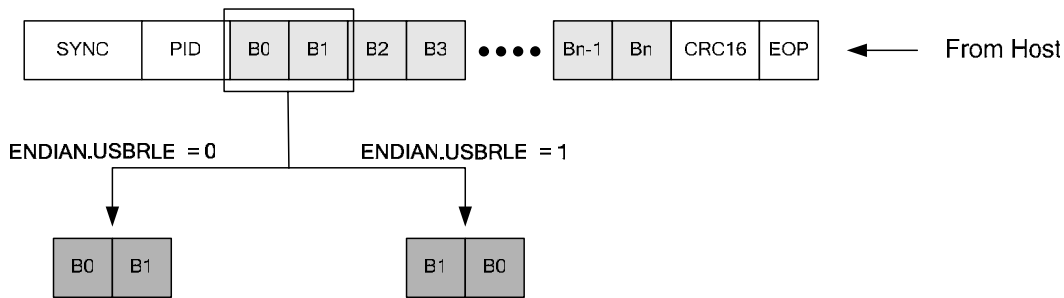

Figure 38 Reading Little/Big Endian

### 13.15.8 USB Reset

A USB hub may signal reset at any time. When reset signaling is detected on the bus, the USB Controller will set `USBCIF.RSTIF` and generate an interrupt if `USBCIE.RSTIE` is set. The firmware should take appropriate action when a USB Reset occurs. A USB Reset would normally cause the system to be initialized to a known reset state. The USB function will typically be reset one or more times during the enumeration phase right after the USB cable is connected. A USB Reset places the device in the default state. In this state the device will only respond to address 0 (the default address).

The following actions are performed by the USB Controller when a USB Reset occurs:

- `USBADDR` is set to 0
- `USBINDEX` is set to 0
- All endpoint FIFOs are flushed
- `E0CSR`, `USBCSIL`, `USBCSIH`, `USBCSOL`, `USBCSOH` are cleared.
- All interrupts, except suspend, are enabled
- An interrupt is generated

Thus, firmware should close all pipes and wait for a new enumeration phase when USB Reset is detected.

### 13.15.9 Suspend and Resume

The USB Controller will enter suspend mode when the USB bus has been continuously idle for 3 ms. An interrupt will be generated if the `USBCIE.SUSPENDIE` is set.

While in suspend mode, only limited current can be sourced from the USB bus. See the USB 2.0 Specification [2] for details about this. To be able to meet the suspend current requirement, the **CC2511Fx** should be taken down to PM1 when suspend is detected. The **CC2511Fx** should not enter PM2 or PM3 since this will reset the USB Controller.

Any valid non-idle signaling on the USB bus will cause the USB Resume Interrupt to be generated and wake up the system if the USB Resume Interrupt is configured correctly. Refer to 13.15.4.1 for details about how to set up the USB Resume Interrupt.

When the system wakes up (enters PM0) from suspend no USB registers must be accessed before XOSC has stabilized.

Be aware that the USB Controller will stay in suspend mode until XOSC has stabilized and non-idle signaling is detected on the USB bus. The `USBCIF.RESUMEIF` interrupt flag will be set and a USB Interrupt will be generated if enabled when the USB Controller exits from suspend mode.

USB Reset will also wake up the system from suspend. The USB Resume Interrupt will be generated, but the `USBCIF.RSTIF` interrupt flag will be set instead of the `USBCIF.RESUMEIF` interrupt flag.

### 13.15.10 Remote Wakeup

The USB Controller can resume from suspend by signaling resume to the USB hub. Resume is performed by setting `USBPOW.RESUME` to 1 for approximately 10 ms. According to the USB 2.0 Specification, the resume signaling must be present for at least 1 ms and no more

than 15 ms. It is, however, recommended to keep the resume signaling for approximately 10 ms. Notice that the device must report back to the USB host that it supports Remote Wakeup when the host sends the GET\_STATUS Standard Device Request.

13.15.11 USB Registers

This section describes all USB registers used for control and status for the USB. The USB registers reside in XDATA memory space in the region 0xDE00-0xDE3F. These registers can be divided

into three groups: The Common USB Registers, The Indexed Endpoint Registers and the Endpoint FIFO Registers. Overview of Common USB Registers. Table 51, Table 52 and Table 53 give an overview of register addresses for each of the three groups respectively while the remaining tables in this section describe each register. The Indexed Endpoint Registers represent the currently selected endpoint. The USBINDEX register is used to select the endpoint.

Notice that the upper register addresses 0xDE2C – 0xDE3F are reserved.

XDATA Address	Register	Description
0xDE00	USBADDR	Function Address
0xDE01	USBPOW	Power/Control Register
0xDE02	USBIIF	IN Endpoints and EP0 Interrupt Flags
0xDE03	-	Reserved
0xDE04	USBOIF	OUT Endpoints Interrupt Flags
0xDE05	-	Reserved
0xDE06	USBCIF	Common USB Interrupt Flags
0xDE07	USBIIE	IN Endpoints and EP0 Interrupt Enable Mask
0xDE08	-	Reserved
0xDE09	USBOIE	Out Endpoints Interrupt Enable Mask
0xDE0A	-	Reserved
0xDE0B	USBCIE	Common USB Interrupt Enable Mask
0xDE0C	USBFRML	Current Frame Number (Low byte)
0xDE0D	USBFRMH	Current Frame Number (High byte)
0xDE0E	USBINDEX	Selects current endpoint. Make sure this register has the value of the endpoint before any of the registers in Table 52 are accessed. This register must be set to a value in the range 0 – 5.

Table 51 Overview of Common USB Registers

XDATA Address	Register	Description	Valid USBINDEX value(s)
0xDE10	USBMAXI	Max. packet size for IN endpoint	1 – 5
0xDE11	USBCS0	EP0 Control and Status (USBINDEX = 0)	0
	USBCSIL	IN EP{1-5} Control and Status Low	1 – 5
0xDE12	USBCSIH	IN EP{1-5} Control and Status High	1 – 5
0xDE13	USBMAXO	Max. packet size for OUT endpoint	1 – 5
0xDE14	USBCSOL	OUT EP{1-5} Control and Status Low	1 – 5
0xDE15	USBCSOH	OUT EP{1-5} Control and Status High	1 – 5
0xDE16	USBCNT0	Number of received bytes in EP0 FIFO (USBINDEX = 0)	0
	USBCNTL	Number of bytes in OUT FIFO Low	1 – 5
0xDE17	USBCNTH	Number of bytes in OUT FIFO High	1 – 5

Table 52 Overview of Indexed Endpoint Registers

XDATA Address	Register	Description
0xDE20	USBF0	Endpoint 0 FIFO
0xDE22	USBF1	Endpoint 1 FIFO
0xDE24	USBF2	Endpoint 2 FIFO
0xDE26	USBF3	Endpoint 3 FIFO
0xDE28	USBF4	Endpoint 4 FIFO
0xDE2A	USBF5	Endpoint 5 FIFO

Table 53 Overview of Endpoint FIFO Registers

**0xDE00: USBADDR – Function Address**

Bit	Field Name	Reset	R/W	Description
7	UPDATE	0	R0	This bit is set when the USBADDR register is written and cleared when the address becomes effective.
6:0	USBADDR[6:0]	0x00	R/W	Function address.

**0xDE01: USBPOW – Power/Control Register**

Bit	Field Name	Reset	R/W	Description
7	ISO_WAIT_SOF	0	R/W	When this bit is set the USB Controller will only send zero length data packets from the time INPKTRDY is set and until the first SOF token has been received. <i>This only applies to isochronous endpoints.</i>
6:4	-	000	R0	Unused
3	RST	0	R	During reset signaling, this bit is set.
2	RESUME	0	R/W	Drive resume signaling for remote wakeup. According to the USB Specification the duration of driving resume must be at least 1 ms and no more than 15 ms. It is recommended to keep this bit set for approximately 10 ms. This bit must not be set until the USB Controller has been in suspend mode for at least 2 ms.
1	SUSPEND	0	R	Suspend Mode entered. This bit will only be used when SUSPEND_EN is set. Reading the USBCIF register or setting RESUME will clear this bit.
0	SUSPEND_EN	0	R/W	Suspend Detection Enable. When this bit is set, the USBCIF.SUSPEND will be set when the USB bus has been idle for 3 ms. An interrupt will also be generated, if USBCIE.SUSPEND is set.

**0xDE02: USBIIF – IN Endpoints and EP0 Interrupt Flags**

Bit	Field Name	Reset	R/W	Description
7:6	-	00	R0	Unused
5	INEP5IF	0	R	Interrupt flag for IN endpoint 5



Bit	Field Name	Reset	R/W	Description
4	INEP4IF	0	R	Interrupt flag for IN endpoint 4
3	INEP3IF	0	R	Interrupt flag for IN endpoint 3
2	INEP2IF	0	R	Interrupt flag for IN endpoint 2
1	INEP1IF	0	R	Interrupt flag for IN endpoint 1
0	EP0IF	0	R	Interrupt flag for endpoint 0

### 0xDE04: USBOIF – Out Endpoints Interrupt Flags

Bit	Field Name	Reset	R/W	Description
7:6	-	00	R0	Unused
5	OUTEP5IF	0	R	Interrupt flag for OUT endpoint 5
4	OUTEP4IF	0	R	Interrupt flag for OUT endpoint 4
3	OUTEP3IF	0	R	Interrupt flag for OUT endpoint 3
2	OUTEP2IF	0	R	Interrupt flag for OUT endpoint 2
1	OUTEP1IF	0	R	Interrupt flag for OUT endpoint 1
0	-	0	R0	Unused

### 0xDE06: USBCIF – Common USB Interrupt Flags

Bit	Field Name	Reset	R/W	Description
7:4	-	0000	R0	Unused
3	SOFIF	0	R	Start-Of-Frame interrupt flag
2	RSTIF	0	R	Reset interrupt flag
1	RESUMIF	0	R	Resume interrupt flag
0	SUSPENDIF	0	R	Suspend interrupt flag

### 0xDE07: USBIE – IN Endpoints and EP0 Interrupt Enable Mask

Bit	Field Name	Reset	R/W	Description
7:6	-	00	R0	Unused
5	INEP5IE	1	R/W	IN endpoint 5 interrupt enable
4	INEP4IE	1	R/W	IN endpoint 4 interrupt enable
3	INEP3IE	1	R/W	IN endpoint 3 interrupt enable
2	INEP2IE	1	R/W	IN endpoint 2 interrupt enable
1	INEP1IE	1	R/W	IN endpoint 1 interrupt enable
0	EP0IE	1	R/W	Endpoint 0 interrupt enable

**0xDE09: USBOIE – Out Endpoints Interrupt Enable Mask**

Bit	Field Name	Reset	R/W	Description
7:6	-	00	R0	Unused
5	OUTEP5IE	1	R/W	OUT endpoint 5 interrupt enable
4	OUTEP4IE	1	R/W	OUT endpoint 4 interrupt enable
3	OUTEP3IE	1	R/W	OUT endpoint 3 interrupt enable
2	OUTEP2IE	1	R/W	OUT endpoint 2 interrupt enable
1	OUTEP1IE	1	R/W	OUT endpoint 1 interrupt enable
0	-	0	R0	Unused

**0xDE0B: USBCIE – Common USB Interrupt Enable Mask**

Bit	Field Name	Reset	R/W	Description
7:4	-	0000	R0	Unused
3	SOFIE	0	R/W	Start-Of-Frame interrupt enable
2	RSTIE	1	R/W	Reset interrupt enable
1	RESUMEIE	1	R/W	Resume interrupt enable
0	SUSPENDIE	0	R/W	Suspend interrupt enable

**0xDE0C: USBFRML – Current Frame Number (Low byte)**

Bit	Field Name	Reset	R/W	Description
7:0	FRAME[7:0]	0x00	R	Low byte of 11-bit frame number

**0xDE0D: USBFRMH – Current Frame Number (High byte)**

Bit	Field Name	Reset	R/W	Description
7:3	-	00000	R0	Always 0
2:0	FRAME[10:8]	000	R	High byte of 11-bit frame number

**0xDE0E: USBINDEX – Current Endpoint Index Register**

Bit	Field Name	Reset	R/W	Description
7:4	-	0000	R0	Always 0
3:0	USBINDEX[3:0]	0000	R/W	Endpoint selected. Must be set to value in the range 0 – 5.

0xDE10: USBMAXI – Max. packet size for IN endpoint

Bit	Field Name	Reset	R/W	Description
7:0	USBMAXI[7:0]	0x00	R/W	Maximum packet size in units of 8 bytes for IN endpoint selected by USBINDEX register. The value of this register should correspond to the <i>wMaxPacketSize</i> field in the Standard Endpoint Descriptor for the endpoint. This register must not be set to a value greater than the available FIFO memory for the endpoint.

0xDE11: USBCS0 – EP0 Control and Status (USBINDEX = 0)

Bit	Field Name	Reset	R/W	Description
7	CLR_SETUP_END	0	R/W H0	Set this bit to clear the SETUP_END bit. It will be cleared automatically.
6	CLR_OUTPKT_RDY	0	R/W H0	Set this bit to clear the OUTPKT_RDY bit. It will be cleared automatically.
5	SEND_STALL	0	R/W H0	Set this bit to make the USB Controller reply with a STALL during the next transfer. This bit is automatically cleared. Used to terminate the current transaction.
4	SETUP_END	0	R	This bit is set if the control transfer ends due to a premature end of control transfer. The FIFO will be flushed and the interrupt flag USBIIF.EP0IF will be set. Set the CLR_SETUP_END bit to clear this bit.
3	DATA_END	0	R/W H0	This bit is used to signal the end of a data transfer. This bit must be set in the following three situations: <ul style="list-style-type: none"> <li>When the last data packet has been loaded and INPKT_RDY is set</li> <li>When the last data packet has been unloaded and CLR_OUTPKT_RDY is set</li> <li>When INPKT_RDY is set without having loaded the FIFO (for sending a zero length data packet).</li> </ul> The USB Controller will clear this bit automatically.
2	SENT_STALL	0	R/W H1	This bit is set when a STALL has been sent. The interrupt flag USBIIF.EP0 will be set. This bit must be cleared from firmware.
1	INPKT_RDY	0	R/W H0	Set this bit when a data packet has been loaded into the EP0 FIFO to notify the USB Controller that a new data packet is ready to be transferred. When the data packet has been sent, this bit is cleared and the interrupt flag is set.
0	OUTPKT_RDY	0	R	Data packet received. This bit is set when an incoming data packet has been placed in the OUT FIFO. Set the CLR_OUTPKT_RDY bit to clear this bit. The interrupt flag is also set when this bit is set.

## 0xDE11: USBCSIL – IN EP{1-5} Control and Status Low

Bit	Field Name	Reset	R/W	Description
7	-	0	R0	Unused
6	CLR_DATA_TOG	0	R/W H0	Setting this bit will reset the data toggle to 0. Thus, setting this bit will force the next data packet to be a DATA0 packet. This bit is automatically cleared.
5	SENT_STALL	0	R/W	This bit is set when a STALL has been sent. The FIFO will be flushed and the INPKT_RDY bit is set to 0. This bit must be cleared from firmware.
4	SEND_STALL	0	R/W	Set this bit to make the USB Controller reply with a STALL handshake when receiving IN tokens. Firmware must clear this bit to end the stall condition. It is not possible to stall an isochronous endpoint, thus this bit will only have effect if the IN endpoint is configured as bulk/interrupt.
3	FLUSH_PACKET	0	R/W H0	Flush next packet that is ready for transfer. The INPKT_RDY bit will be cleared. If there are two packets in the IN FIFO due to double buffering, this bit must be set twice to completely flush the IN FIFO. This bit is automatically cleared.
2	UNDERRUN	0	R/W	This bit is set when INPKT_RDY has not been set when an IN token is received. A zero length data packet is transmitted in response to the IN token. This bit is only used for isochronous endpoints. Firmware should clear this bit.
1	PKT_PRESENT	0	R	This bit is set when there is at least one packet in the IN FIFO.
0	INPKT_RDY	0	R/W H0	Set this bit when a data packet has been loaded into the IN FIFO to notify the USB Controller that a new data packet is ready to be transferred. When the data packet has been sent, this bit is cleared and the interrupt flag is set.

## 0xDE12: USBCSIH – IN EP{1-5} Control and Status High

Bit	Field Name	Reset	R/W	Description
7	AUTOSET	0	R/W	When this bit is set, the INPKT_RDY bit is automatically set when a data packet of maximum size (specified by USBMAXI) has been loaded into the IN FIFO.
6	ISO	0	R/W	Selects IN endpoint type. 0 – Bulk/Interrupt 1 – Isochronous
5:4	-	10	R	Unused
3	FORCE_DATA_TOG	0	R/W	Setting this bit will force the IN endpoint data toggle to switch and the data packet to be flushed from the IN FIFO even though an ACK was received. This feature can be useful when reporting rate feedback for isochronous endpoints.
2:1	-	0	R0	Unused
0	IN_DBL_BUF	0	R/W	Set this bit to enable double buffering of data packets.

**0xDE13: USBMAXO – Max. packet size for OUT endpoint**

Bit	Field Name	Reset	R/W	Description
7:0	USBMAXO[7:0]	0x00	R/W	Maximum packet size in units of 8 bytes for OUT endpoint selected by USBINDEX register. The value of this register should correspond to the <i>wMaxPacketSize</i> field in the Standard Endpoint Descriptor for the endpoint. This register must not be set to a value greater than the available FIFO memory for the endpoint.

**0xDE14: USBCSOL – OUT EP{1-5} Control and Status Low**

Bit	Field Name	Reset	R/W	Description
7	CLR_DATA_TOG	0	R/W H0	Setting this bit will reset the data toggle to 0. Thus, setting this bit will force the next data packet to be a DATA0 packet. This bit is automatically cleared.
6	SENT_STALL	0	R/W	This bit is set when a STALL has been sent. This bit must be cleared from firmware.
5	SEND_STALL	0	R/W	Set this bit to make the USB Controller reply with a STALL handshake. Firmware must clear this bit to end the stall condition. It is not possible to stall an isochronous endpoint, thus this bit will only have effect if the OUT endpoint is configured as bulk/interrupt.
4	FLUSH_PACKET	0	R/W H0	Flush next packet that is to be read from the OUT FIFO. If there are two packets in the IN FIFO due to double buffering, this bit must be set twice to completely flush the IN FIFO. This bit is automatically cleared.
3	DATA_ERROR	0	R	This bit is set if there is a CRC or bit-stuff error in the packet received. Cleared when OUTPKT_RDY is cleared. This bit will only be valid if the OUT endpoint type is isochronous. Bulk/Interrupt endpoints use retransmission when errors occur while there is no retransmission for isochronous endpoints.
2	OVERRUN	0	R/W	This bit is set when an OUT packet cannot be loaded into the OUT FIFO and the OUT endpoint type is isochronous. Firmware should clear this bit.
1	FIFO_FULL	0	R	OUT FIFO full. No more packets can be loaded.
0	OUTPKT_RDY	0	R/W	This bit is set when a packet has been successfully received and is ready to be read from OUT FIFO. This bit should be cleared as soon as the packet has been unloaded from the FIFO. The interrupt flag for the OUT endpoint is set when this bit is set.

**0xDE15: USBCSOH – OUT EP{1-5} Control and Status High**

Bit	Field Name	Reset	R/W	Description
7	AUTOCLEAR	0	R/W	When this bit is set, the OUTPKT_RDY bit is automatically cleared when a data packet of maximum size (specified by USBMAXO) has been unloaded into the OUT FIFO.
6	ISO	0	R/W	Selects OUT endpoint type. 0 – Bulk/Interrupt 1 – Isochronous
5:4	-	00	R/W	Unused. Must be 0.
3:1	-	000	R0	Unused
0	OUT_DBL_BUF	0	R/W	Set this bit to enable double buffering of data packets.

**0xDE16: USBCNT0 – Number of received bytes in EP0 FIFO (USBINDEX = 0)**

Bit	Field Name	Reset	R/W	Description
7:6	-	00	R0	Unused.
5:0	USBCNT0[5:0]	0x00	R	Number of received bytes into EP 0 FIFO. Only valid when OUTPKT_RDY is set.

**0xDE16: USBCNTL – Number of bytes in OUT FIFO Low**

Bit	Field Name	Reset	R/W	Description
7:0	USBCNT[7:0]	0x00	R	Number of received bytes into OUT FIFO selected by USBINDEX register. Only valid when OUTPKT_RDY is set.

**0xDE17: USBCNTH – Number of bytes in OUT FIFO High**

Bit	Field Name	Reset	R/W	Description
7:3	-	0x00	R0	Unused
2:0	USBCNT[10:8]	0x00	R	Number of received bytes into OUT FIFO selected by USBINDEX register. Only valid when OUTPKT_RDY is set.

**0xDE20: USBF0 – Endpoint 0 FIFO**

Bit	Field Name	Reset	R/W	Description
7:0	USBF0[7:0]	0x00	R/W	Endpoint 0 FIFO register. Reading this register causes one byte to be extracted from the EP0 FIFO. The value of the extracted value is returned. Writing to this register inserts one byte with the value written into the EP0 FIFO. <i>Note: The FIFO memory for EP0 is used for both incoming and outgoing data packets.</i>

### 0xDE22: USBF1 – Endpoint 1 FIFO

Bit	Field Name	Reset	R/W	Description
7:0	USBF1[7:0]	0x00	R/W	Endpoint 1 FIFO register. Reading this register causes one byte to be extracted from the EP1 OUT FIFO. The value of the extracted value is returned. Writing to this register inserts one byte with the value written into the EP1 IN FIFO.

### 0xDE24: USBF2 – Endpoint 2 FIFO

Bit	Field Name	Reset	R/W	Description
7:0	USBF2[7:0]	0x00	R/W	Endpoint 2 FIFO register. Reading this register causes one byte to be extracted from the EP2 OUT FIFO. The value of the extracted value is returned. Writing to this register inserts one byte with the value written into the EP2 IN FIFO.

### 0xDE26: USBF3 – Endpoint 3 FIFO

Bit	Field Name	Reset	R/W	Description
7:0	USBF3[7:0]	0x00	R/W	Endpoint 3 FIFO register. Reading this register causes one byte to be extracted from the EP3 OUT FIFO. The value of the extracted value is returned. Writing to this register inserts one byte with the value written into the EP3 IN FIFO.

### 0xDE28: USBF4 – Endpoint 4 FIFO

Bit	Field Name	Reset	R/W	Description
7:0	USBF4[7:0]	0x00	R/W	Endpoint 4 FIFO register. Reading this register causes one byte to be extracted from the EP4 OUT FIFO. The value of the extracted value is returned. Writing to this register inserts one byte with the value written into the EP4 IN FIFO.

### 0xDE2A: USBF5 – Endpoint 5 FIFO

Bit	Field Name	Reset	R/W	Description
7:0	USBF5[7:0]	0x00	R/W	Endpoint 5 FIFO register. Reading this register causes one byte to be extracted from the EP5 OUT FIFO. The value of the extracted value is returned. Writing to this register inserts one byte with the value written into the EP5 IN FIFO.

### 13.16 Flash Controller

The **CC2510Fx/CC2511Fx** contains 8, 16 or 32 KB flash memory for storage of program code. The flash memory is programmable from the user software.

The Flash Controller handles writing and erasing the embedded flash memory. The flash memory consists of 8, 16 or 32 pages of 1024 bytes each, depending on the total flash size. The flash memory is byte-addressable from the CPU and 16-bit word-programmable.

The flash controller has the following features:

- 16-bit word programmable
- Page erase
- Lock bits for write-protection and code security
- Flash erase timing 20 ms
- Flash write timing 20  $\mu$ s

#### 13.16.1 Flash Write

Data is written to the flash memory by using a program command initiated by writing the Flash Control register, **FCTL**. Flash write operations can program any number of locations in the flash memory at a time – it is however important to make sure the pages to be written are erased first.

A write operation is performed using one out of two methods;

- Through DMA transfer
- Through CPU SFR access.

The DMA transfer method is the preferred way to write to the flash memory.

A write operation is initiated by writing a 1 to **FCTL.WRITE**. The address to start writing at, is given by **FADDRH:FADDRL**. During each single write operation **FCTL.SWBSY** is set high. During a write operation the data written to the **FWDATA** register is forwarded to the flash memory. The flash memory is 16-bit word-

programmable, meaning data is written as 16-bit words. Therefore the actual writing to flash memory takes place each time two bytes have been written to **FWDATA**.

The CPU will not be able to access the flash, e.g. to read program code, while a flash write operation is in progress. Therefore the program code executing the flash write must be executed from RAM, meaning that the program code must reside in the area 0xF000 to 0xFF00 in **XDATA/CODE** memory space.

When a flash write operation is executed from RAM, the CPU continues to execute code from the next instruction after the write to **FWDATA**, which initiated the flash write operation.

The **FCTL.SWBSY** bit must be 0 before accessing the flash after a flash write, otherwise an access violation occurs. This also means that **FCTL.SWBSY** must be 0 before program execution can continue at a location in flash memory.

#### 13.16.1.1 DMA Flash Write

When using DMA write operations, the data to be written into flash is stored in **DATA/XDATA** memory. A DMA channel is configured to read the data to be written from memory and write this data to the Flash Write Data register, **FWDATA** with the DMA trigger event **FL** enabled. Thus the Flash Controller will trigger a DMA transfer when the Flash Write Data register, **FWDATA**, is ready to receive new data. The DMA channel should be configured to perform a block to fixed, single mode, byte size transfers.

When the DMA channel is armed, starting a flash write will trigger the first DMA transfer.

Figure 39 shows an example how a DMA channel is configured and how a DMA transfer is initiated to write a block of data from a location in **XDATA** to flash memory.



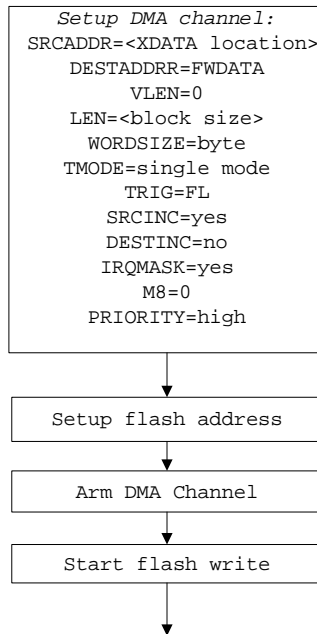

```

; Write a consecutive block of data from XDATA to consecutive locations in
; flash memory using DMA
; Assumes 26 MHz system clock is used
;

```

```

    MOV    DPTR,#DMACFG          ;load data pointer with address for DMA
                                ;channel configuration and
                                ;start writing DMA configuration
    MOV    A,#SRC_HI            ;source data high address
    MOVX   @DPTR,A              ;
    INC    DPTR                  ;
    MOV    A,#SRC_LO            ;source data low address
    MOVX   @DPTR,A              ;
    INC    DPTR                  ;
    MOV    A,#0DFh              ;destination high address = HIGH(X_FWDATA)
    MOVX   @DPTR,A              ;
    INC    DPTR                  ;
    MOV    A,#0AFh              ;destination low address = LOW(X_FWDATA)
    MOVX   @DPTR,A              ;
    INC    DPTR                  ;
    MOV    A,#BLK_LEN           ;block length
    MOVX   @DPTR,A              ;
    INC    DPTR                  ;
    MOV    A,#012h              ;8 bits, single mode, use FL trigger
    MOVX   @DPTR,A              ;
    INC    DPTR                  ;
    MOV    A,#042h              ;increment source by 1, don't increment
    MOVX   @DPTR,A              ;destination, mask interrupt, high DMA
                                ;priority
    MOV    DMA0CFGL,#DMACFG_LO ;setup start address for current DMA
    MOV    DMA0CFGH,#DMACFG_HI ;configuration
    MOV    DMAARM,#01h          ;arm DMA channel 0
    MOV    FADDRH,#00h          ;setup flash address high
    MOV    FADDRL,#01h          ;setup flash address low
    MOV    FWT,#2Ah             ;setup flash timing
    MOV    FCTL,#02h            ;start flash page write => trigger DMA
    .
    .

```

Figure 39: Flash write using DMA

### 13.16.1.2 CPU Flash Write

The CPU can also write directly to the flash. The CPU writes data to the Flash Write Data register, FWDATA. The flash memory is written each time two bytes have been written to FWDATA. The CPU can poll the FCTL.SWBSY status to

determine when the flash is ready for two more bytes to be written to FWDATA..

#### Performing flash write from XDATA

The steps required to start a flash write operation from XDATA are shown in Figure 40 on page 186.

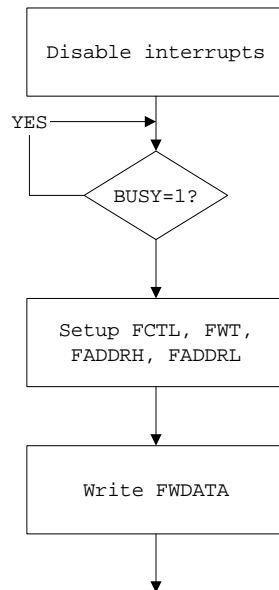

```

; Write 32-bit word from XDATA
; Assumes 26 MHz system clock is used
;
CLR    EA                ;mask interrupts
C1:   MOV    A,FCTL       ;wait until flash controller is ready
      JB    ACC.7,C1
      MOV   FADDRH,#00h   ;setup flash address high
      MOV   FADDRL,#01h   ;setup flash address low
      MOV   FWT,#2Ah      ;setup flash timing
      MOV   FCTL,#02h     ;set flash page write
      MOV   FWDATA,#12h   ;first byte
      MOV   FWDATA,#34h   ;second byte, initiates write
  
```

Figure 40 : Flash write performed from XDATA

### 13.16.2 Flash Page Erase

A page erase is initiated by setting FCTL.ERASE to 1. The page addressed by FADDRH[6:1] is erased when a page erase is initiated. Note that if a page erase is initiated simultaneously with a page write, i.e. FCTL.WRITE is set to 1, the page erase will be performed before the page write operation. The FCTL.BUSY bit can be polled to see when the page erase has completed.

*Note: if flash erase operations are performed from within flash memory and the watchdog timer is enabled, a watchdog timer interval must be selected that is longer than 20 ms, the duration of the flash erase operation, so that the CPU will manage to clear the watchdog timer.*

Performing flash erase from flash memory.

The steps required to perform a flash page erase from within flash memory are outlined in Figure 41.

Note that, while executing program code from within flash memory, when a flash

erase or write operation is initiated, program execution will resume from the next instruction when the flash controller has completed the operation.

```

; Erase page in flash memory
; Assumes 26 MHz system clock is used
;
CLR    EA                                ;mask interrupts
C1:   MOV    A,FCTL                        ;wait until flash controller is ready
      JB    ACC.7,C1
      MOV    FADDRH,#00h                  ;setup flash address high
      MOV    FADDRL,#01h                  ;setup flash address low
      MOV    FWT,#2Ah                     ;setup flash timing
      MOV    FCTL,#01h                    ;erase page
      RET                                  ;continues here when flash is ready

```

**Figure 41: Flash page erase performed from flash memory**

### 13.16.3 Flash Lock Protection

For software protection purposes a set of lock protection bits can be written once after each chip erase has been performed. The lock protect bits can only be written through the Debug Interface. There are three kinds of lock protect bits as described in this section. The flash lock bits reside at location 0x000 in the Flash Information page as described in section 12.11.

The `LSIZE[2:0]` lock protect bits are used to define a section of the flash memory which is write protected. The size of the write protected area can be set by the `LSIZE[2:0]` lock protect bits in sizes of eight steps from 0 to 32 KB. Notice that the only supported value for `LSIZE[2:0]` is 0 and 7 for CC2510F8, CC2511F8, CC2510F16 and CC2511F16.

The second type of lock protect bits is `BBLOCK`, which is used to lock the boot sector page (page 0 ranging from address 0 to 0x03FF). When `BBLOCK` is set to 0, the boot sector page is locked.

The third type of lock protect bit is `DBGLOCK`, which is used to disable hardware debug support through the Debug Interface. When `DBGLOCK` is set to 0, all debug commands are disabled.

The lock protect bits are written as a normal flash write to `FWDATA`, but the Debug Interface needs to select the Flash Information Page first instead of the Flash Main Page which is the default setting. The Information Page is selected through the Debug Configuration which is written through the Debug Interface only. Refer to section 12.9 on page 60 for details on how to select the Flash Information Page using the Debug Interface.

Table 54 defines the byte containing the flash lock protection bits. Note that this is not an SFR register, but instead the byte stored at location 0x000 in Flash Information Page.

Table 54: Flash Lock Protection Bits Definition

Bit	Name	Description
7:5	-	Reserved, write as 0
4	BBLOCK	Boot Block Lock 0 Page 0 is write protected 1 Page 0 is writeable, unless LSIZE is 000
3:1	LSIZE[2:0]	Lock Size. Sets the size of the upper Flash area which is write protected. Byte sizes are listed below 000 32K bytes (All pages) 001 24K bytes (CC2510F32 and CC2511F32 only) 010 16K bytes (CC2510F32 and CC2511F32 only) 011 8K bytes (CC2510F32 and CC2511F32 only) 100 4K bytes (CC2510F32 and CC2511F32 only) 101 2K bytes (CC2510F32 and CC2511F32 only) 110 1K bytes (CC2510F32 and CC2511F32 only) 111 0 bytes (no pages)
0	DBGLOCK	Debug lock bit 0 Disable debug commands 1 Enable debug commands

13.16.4 Flash Write Timing

The Flash Controller contains a timing generator which controls the timing sequence of flash write and erase operations. The timing generator uses the information set in the Flash Write Timing register, `FWT.FWT[5:0]`, to set the internal timing. `FWT.FWT[5:0]` must be set to a value according to the currently selected system clock frequency.

The value set in the `FWT.FWT[5:0]` shall be set according to the system clock frequency by the following equation.

$$FWT = \frac{21000 * F}{16 * 10^9}$$

Where  $F$  is the system clock frequency. The initial value held in `FWT.FWT[5:0]` after a reset is 0x11 which corresponds to 13 MHz CPU clock frequency (High speed RC oscillator).

The `FWT` values for the possible system clock frequencies are given in Table 55.

System clock frequency (MHz)	FWT
13	0x11
16	0x15
24	0x20
26	0x23

Table 55: Flash timing (FWT) values

13.16.5 Flash Controller Registers

The Flash Controller registers are described in this section.

## FCTL (0xAE) – Flash Control

Bit	Name	Reset	R/W	Description
7	BUSY	0	R	Indicates that write or erase is in operation
6	SWBSY	0	R	Indicates that single write is busy; avoid writing to FWDATA register while this is true
5	–	0	R/W	Not used.
4	CONTRD	R/W	0	Continuous read enable mode 0 Avoid wasting power; turn on read enables to flash only when needed 1 Enable continuous read enables to flash when read is to be done. Reduces internal switching of read enables, but greatly increases power consumption.
3:2		0	R/W	Not used.
1	WRITE	0	R0/W	Page Write. Start writing page given by FADDRH : FADDRL. If ERASE is set to 1, a page erase is performed before the write.
0	ERASE	0	R0/W	Page Erase. Erase page that is given by FADDRH : FADDRL

## FWDATA (0xAF) – Flash Write Data

Bit	Name	Reset	R/W	Description
7:0	FWDATA[ 7 : 0 ]	0x00	R/W	Flash write data. Data written to FWDATA is written to flash when FCTL . WRITE is set to 1.

## FADDRH (0xAD) – Flash Address High Byte

Bit	Name	Reset	R/W	Description
7:6	-	00	R/W	Not used
5:0	FADDRH[ 6 : 0 ]	0x00	R/W	High byte of flash address Bits 5:1 will select page to access, while bit 0 is MSB of row access.

## FADDRL (0xAC) – Flash Address Low Byte

Bit	Name	Reset	R/W	Description
7:0	FADDRL[ 7 : 0 ]	0x00	R/W	Low byte of flash address Bit 0 of FADDRH and bits 7:6 will select which row to write to, while bits 5:0 will select which location to write to.

## FWT (0xAB) – Flash Write Timing

Bit	Name	Reset	R/W	Description
7:6	–	00	R/W	Not used
5:0	FWT[ 5 : 0 ]	0x25	R/W	Flash Write Timing. Controls flash timing generator.

## 14 Crystal Oscillator

### 14.1 **CC2510Fx** Crystal Oscillator

A crystal in the frequency range 26 MHz-27 MHz must be connected between the XOSC\_Q1 and XOSC\_Q2 pins. The oscillator is designed for parallel mode operation of the crystal. In addition, loading capacitors (C201 and C211) for the crystal are required. The loading capacitor values depend on the total load capacitance,  $C_L$ , specified for the crystal. The total load capacitance seen between the crystal terminals should equal  $C_L$  for the crystal to oscillate at the specified frequency.

$$C_L = \frac{1}{\frac{1}{C_{211}} + \frac{1}{C_{201}}} + C_{\text{parasitic}}$$

The parasitic capacitance is constituted by pin input capacitance and PCB stray capacitance. Total parasitic capacitance is typically 2.5 pF.

The crystal oscillator circuit is shown in Figure 7. Typical component values for different values of  $C_L$  are given in Table 9.

The crystal oscillator is amplitude regulated. This means that a high current is used to start up the oscillations. When the amplitude builds up, the current is reduced to what is necessary to maintain approximately 0.4 Vpp signal swing. This ensures a fast start-up, and keeps the drive level to a minimum. The ESR of the crystal should be within the specification in order to ensure a reliable start-up (see section Table 9 on page 15).

### 14.2 **CC2511Fx** Crystal Oscillator

The CC2511Fx requires a 48 MHz frequency crystal to be used. If a fundamental crystal is used, only the loading capacitor values need to be changed compared to the CC2510Fx crystal oscillator. If a 3<sup>rd</sup> overtone crystal is used, an additional inductor and capacitor is needed. Figure 9 shows this configuration. Values for capacitors and the inductor are given in Table 27.

## 15 Radio

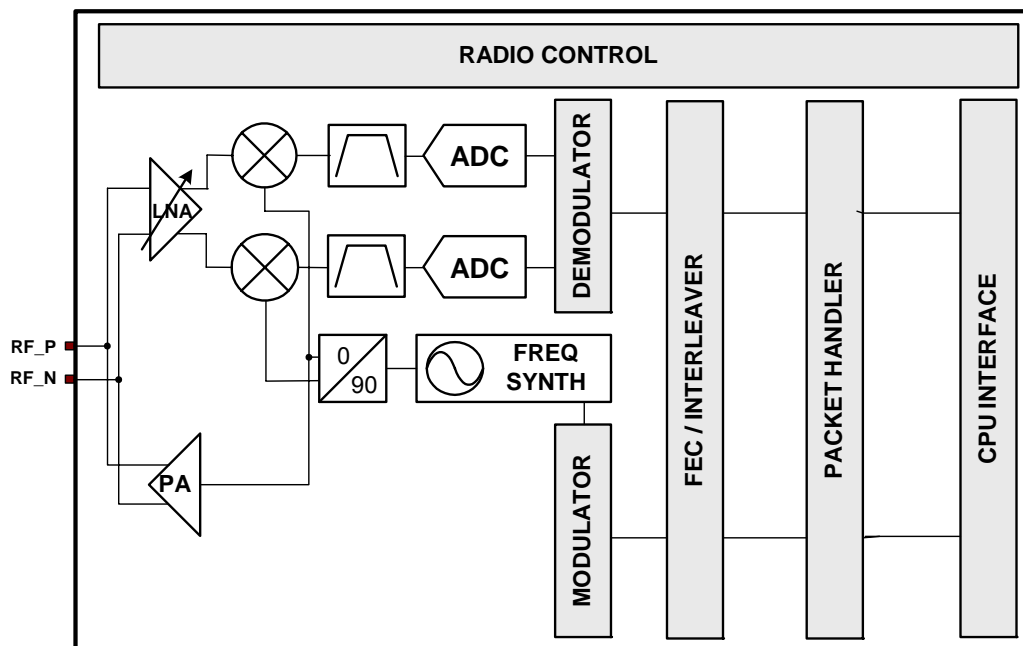

Figure 42: CC2510Fx/CC2511Fx Radio Module

A simplified block diagram of the radio module in the *CC2510Fx/CC2511Fx* is shown in Figure 42.

*CC2510Fx/CC2511Fx* features a low-IF receiver. The received RF signal is amplified by the low-noise amplifier (LNA) and down-converted in quadrature (I and Q) to the intermediate frequency (IF). At IF, the I/Q signals are digitized by the ADCs. Automatic gain control (AGC), fine channel filtering, demodulation bit/packet synchronization is performed digitally.

The transmitter part of *CC2510Fx/CC2511Fx* is based on direct synthesis of the RF frequency.

The frequency synthesizer includes a completely on-chip LC VCO and a 90 degrees phase shifter for generating the I

and Q LO signals to the down-conversion mixers in receive mode.

The 26/48 MHz crystal oscillator generates the reference frequency for the synthesizer, as well as clocks for the ADC and the digital part.

An SFR register interface is used for data buffer access from the CPU. Configuration and status registers are accessed through registers mapped to XDATA memory.

The digital baseband includes support for channel configuration, packet handling and data buffering. An on-chip voltage regulator delivers a regulated 1.8 V supply voltage.

### 15.1 Command strobcs

The CPU uses a set of *command strobcs* to control operation of the radio in *CC2510Fx/CC2511Fx*.

Command strobcs may be viewed as single byte instructions which each control some function of the radio. These command strobcs must be used to enable

the frequency synthesizer, enable receive mode, enable transmit mode and other functions.

The command strobes are issued by writing to the RFST SFR register. The list of all strobe commands which are defined is given in Table 56.

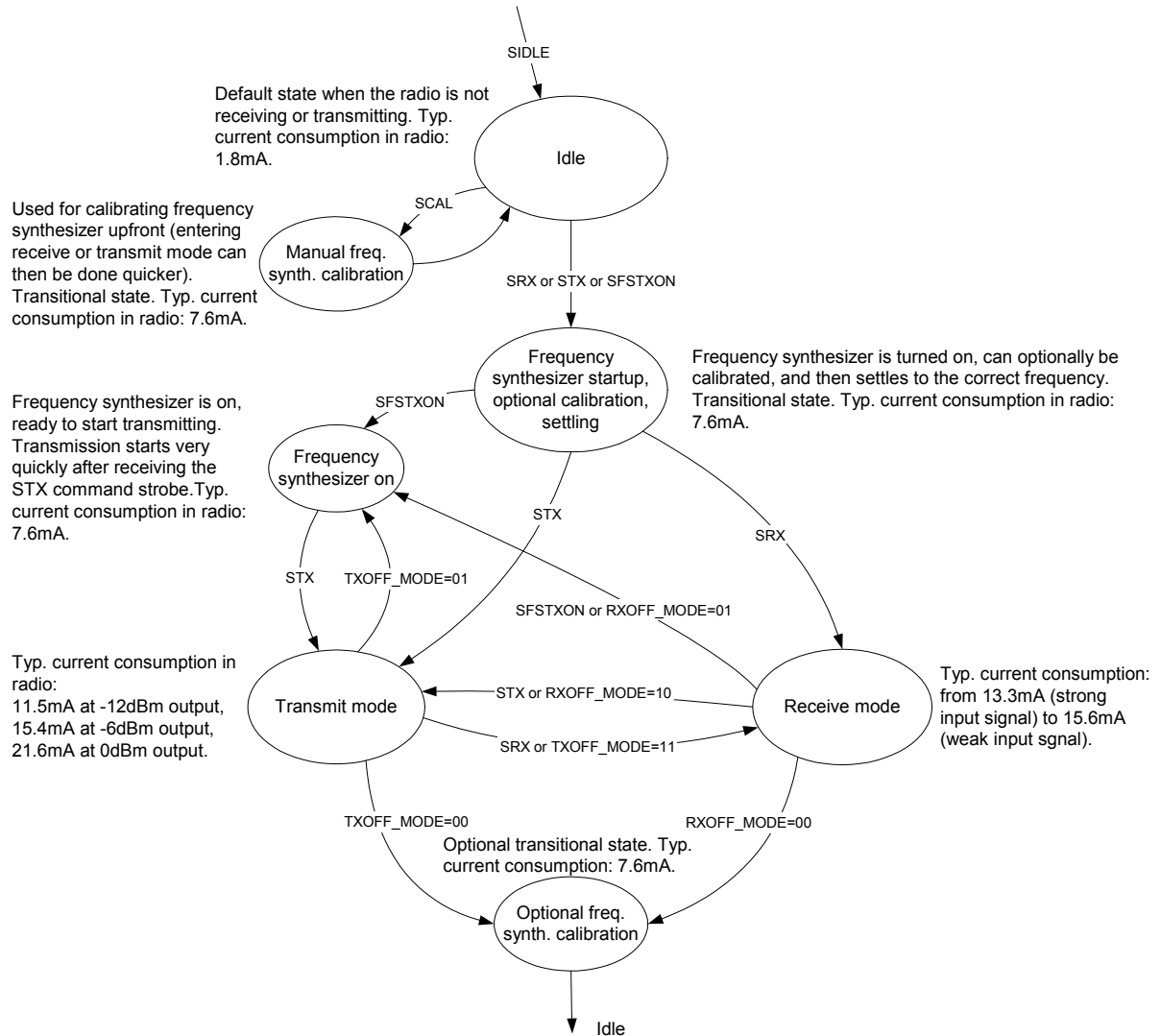

Figure 43: Simplified state diagram, with typical usage and current consumption in radio



RFST Value	Command Strobe Name	Description
0x00	SFSTXON	Enable and calibrate frequency synthesizer (if MCSM0 . FS_AUTOCAL=1). While in RX / TX issuing this command strobe will force the radio to go to a wait state where only the synthesizer is running (for quick RX / TX turnaround).
0x01	SCAL	Calibrate frequency synthesizer and turn it off (enables quick start).
0x02	SRX	Enable RX. Perform calibration first if coming from IDLE and MCSM0 . FS_AUTOCAL=1.
0x03	STX	In IDLE state: Enable TX. Perform calibration first if MCSM0 . FS_AUTOCAL=1. If in RX state and CCA is enabled: Only go to TX if channel is clear.
0x04	SIDLE	Exit RX / TX, turn off frequency synthesizer.
0x05	SAFC	Perform AFC adjustment of the frequency synthesizer
all others	SNOP	No operation.

Table 56: Command strobes

## 15.2 Radio Registers

The operation of the radio is configured through a set of RF registers. These RF registers are mapped to XDATA memory space as shown in Figure 10 on page 36.

In addition to configuration registers, the RF registers also provide status information from the radio.

The RF registers control/status bits are referred to where appropriate in the following sections while section 15.18 on page 216 gives a full description of all RF registers.

## 15.3 Interrupts

The radio is associated with two interrupt vectors on the CPU. These are the RFTXRX interrupt (interrupt 0) and the RFIF interrupt (interrupt 12) with the following functions

- RFTXRX: RX data ready or TX data complete
- RF: all other RFIF interrupt flags

The RF interrupt vector combines the interrupts in RFIF shown on page 194. Note that these RF interrupts are rising-edge triggered. Thus an interrupt is generated when e.g. the SFD status flag goes from 0 to 1.

The RF interrupt can also be used to trigger a timer capture in Timer 1.

The RF interrupt flags are described in the next section.

### 15.3.1 Interrupt registers

Two of the main interrupt control SFR registers are used to enable the RF and RFTXRX interrupts. These are the following:

- RFTXRX : IEN0 . RFTXRXIE
- RF : IEN2 . RFIE

Two main interrupt flag SFR registers hold the RF and RFERR interrupt flags. These are the following:

- RFTXRX : TCON . RFTXRX
- RF : S1CON . RFIF

Refer to section 12.7 for details about the interrupts.

The RF interrupt is the combined interrupt from six different sources in the radio. Two SFR registers are used for setting the six individual RFIF radio interrupt flags and interrupt enables. These are the RFIF and RFIM registers.

The interrupt flags in SFR register RFIF show the status for each interrupt source for the RF interrupt vector.

The interrupt enable bits in RFIM are used to disable individual interrupt sources for the RF interrupt vector. Note that masking

an interrupt source in RFIM does not affect the update of the status in the RFIF register.

Due to the use of the individual interrupt masks in RFIM, and the main interrupt mask for the RF interrupt given by IEN2.RFIE there is two-layered masking of this interrupt. Special attention needs to

be taken when processing this type of interrupt as described below.

To clear the RF interrupt, S1CON.RFIF and the interrupt flag in RFIF need to be cleared. The order and method of doing this is shown in Figure 44. Note that S1CON is cleared after RFIF, otherwise S1CON.RFIF could be set once again due to the same interrupt.

```
MOV    RFIF,#00h           ;clear all interrupt flags
MOV    S1CON,#00h         ;clear main interrupt flags
MOV    RFIM,RFIM          ;set interrupt mask
```

**Figure 44: Clearing RF Interrupt**

**RFIF (0xE9) – RF Interrupt Flags**

Bit	Name	Reset	R/W	Description
7	IRQ_TXUNF	0	R/W0	TX underflow. 0 No interrupt pending 1 Interrupt pending
6	IRQ_RXOVF	0	R/W0	RX overflow. 0 No interrupt pending 1 Interrupt pending
5	IRQ_TIMEOUT	0	R/W0	RX timeout, no packet has been received in the programmed period. 0 No interrupt pending 1 Interrupt pending
4	IRQ_DONE	0	R/W0	Packet received/transmitted. Also used to detect underflow/overflow conditions. 0 No interrupt pending 1 Interrupt pending
3	IRQ_CS	0	R/W0	Carrier sense. 0 No interrupt pending 1 Interrupt pending
2	IRQ_PQT	0	R/W0	Preamble quality reached. 0 No interrupt pending 1 Interrupt pending
1	IRQ_CCA	0	R/W0	Clear Channel Assessment 0 No interrupt pending 1 Interrupt pending
0	IRQ_SFD	0	R/W0	Start of Frame Delimiter, sync word detected 0 No interrupt pending 1 Interrupt pending

**RFIM (0x91) – RF Interrupt Mask**

Bit	Name	Reset	R/W	Description
7	IM_TXUNF	0	R/W	TX underflow. 0 Interrupt disabled 1 Interrupt enabled
6	IM_RXOVF	0	R/W	RX overflow. 0 Interrupt disabled 1 Interrupt enabled
5	IM_TIMEOUT	0	R/W	RX timeout, no packet has been received in the programmed period. 0 Interrupt disabled 1 Interrupt enabled
4	IM_DONE	0	R/W	Packet received/transmitted. Also used to detect underflow/overflow conditions. 0 Interrupt disabled 1 Interrupt enabled
3	IM_CS	0	R/W	Carrier sense. 0 Interrupt disabled 1 Interrupt enabled
2	IM_PQT	0	R/W	Preamble quality reached. 0 Interrupt disabled 1 Interrupt enabled
1	IM_CCA	0	R/W	Clear Channel Assessment 0 Interrupt disabled 1 Interrupt enabled
0	IM_SFD	0	R/W	Start of Frame Delimiter, sync word detected 0 Interrupt disabled 1 Interrupt enabled

**15.4 TX/RX Data Transfer**

Transmit data is written to the radio when writing to the RF Data register, RFD. Received data is returned when the RFD register is read.

It is required that the user software uses FIFO structures in memory to implement RX and TX FIFOs. In most cases it is recommended that the transfer of data between FIFOs in memory and the RF

Data register, RFD, involves the use of DMA channels with RFD as source/destination and DMA trigger RADIO. For description on the usage of DMA, refer to section 13.2 on page 84.

A simple example of writing TX data to the radio is shown in Figure 45. This example does not use DMA, but illustrates some of the basic principles.

```

; Start radio TX
; simple example, assumes required frequency, modulation format and
; data rate has been set in RF registers
;
MOV    DPTR,PA_TABLE0    ;setting PA output power
MOV    A,#0FFh           ;
MOVX   @DPTR,A           ;
MOV    CLKCON,#00H      ;select 26 MHz XOSC
MOV    RFST,#03H        ;start TX with STX command strobe
C1:    JNB    IE0,C1      ;wait for interrupt flag telling radio is
CLR    IE0              ;ready to accept data, then write
MOV    RFD,#02H         ;first data to radio, packet length=2
C2:    JNB    IE0,C2      ;wait for radio
CLR    IE0              ;
MOV    RFD,#12H         ;send first byte in payload
C3:    JNB    IE0,C3      ;wait for radio
CLR    IE0              ;
MOV    RFD,#34H         ;send second byte in payload
;done

```

Figure 45: Simple RF transmit example

### 15.5 Data Rate Programming

The data rate used when transmitting, or the data rate expected in receive is programmed by the MDMCFG3.DRATE\_M and the MDMCFG4.DRATE\_E configuration registers. The data rate is given by the formula below. As the formula shows, the programmed data rate depends on the crystal frequency.

$$R_{DATA} = \frac{(256 + DRATE\_M) \cdot 2^{DRATE\_E}}{2^{28}} \cdot f_{XOSC}$$

The following approach can be used to find suitable values for a given data rate:

$$DRATE\_E = \left\lceil \log_2 \left( \frac{R_{DATA} \cdot 2^{20}}{f_{XOSC}} \right) \right\rceil$$

$$DRATE\_M = \frac{R_{DATA} \cdot 2^{28}}{f_{XOSC} \cdot 2^{DRATE\_E}} - 256$$

If DRATE\_M is rounded to the nearest integer and becomes 256, increment DRATE\_E and use DRATE\_M=0.

The data rate can be set from 1.2 kbps to 500 kbps with the minimum step size as shown in Table 57.

Data rate start	Typical data rate	Data rate stop	Data rate step size
0.8 kbps	1.2 / 2.4 kbps	3.17 kbps	0.0062 kbps
3.17 kbps	4.8 kbps	6.35 kbps	0.0124 kbps
6.35 kbps	9.6 kbps	12.7 kbps	0.0248 kbps
12.7 kbps	19.6 kbps	25.4 kbps	0.0496 kbps
25.4 kbps	38.4 kbps	50.8 kbps	0.0992 kbps
50.8 kbps	76.8 kbps	101.6 kbps	0.1984 kbps
101.6 kbps	153.6 kbps	203.1 kbps	0.3967 kbps
203.1 kbps	250 kbps	406.3 kbps	0.7935 kbps
406.3 kbps	500 kbps	500 kbps	1.5869 kbps

Table 57: Data rate step size

### 15.6 Receiver Channel Filter Bandwidth

In order to meet different channel width requirements, the receiver channel filter is programmable. The `MDMCFG4.CHANBW_E` and `MDMCFG4.CHANBW_M` configuration registers control the receiver channel filter bandwidth, which scales with the crystal oscillator frequency. The following formula gives the relation between the register settings and the channel filter bandwidth:

$$BW_{channel} = \frac{f_{XOSC}}{8 \cdot (4 + CHANBW\_M) \cdot 2^{CHANBW\_E}}$$

The *CC2510Fx/CC2511Fx* supports channel filter bandwidths shown in Table 58.

MDMCFG4. CHANBW_M	MDMCFG4.CHANBW_E			
	00	01	10	11
00	812	406	203	102
01	650	325	162	81
10	541	270	135	68
11	464	232	116	58

Table 58: Channel filter bandwidths [kHz] (26 MHz crystal)

For best performance, the channel filter bandwidth should be selected so that the signal bandwidth occupies at most 80% of the channel filter bandwidth. The channel centre tolerance due to crystal accuracy should also be subtracted from the signal bandwidth. The following example illustrates this:

With the channel filter bandwidth set to 600 kHz, the signal should stay within 80%

of 600 kHz, which is 480 kHz. Assuming 2.44 GHz frequency and  $\pm 20$  ppm frequency uncertainty for both the transmitting device and the receiving device, the total frequency uncertainty is  $\pm 40$  ppm of 2.44 GHz, which is  $\pm 98$  kHz. If the whole transmitted signal bandwidth is to be received within 480 kHz, the transmitted signal bandwidth should be maximum 480 kHz – 2·98 kHz, which is 284 kHz.

### 15.7 Demodulator, Symbol Synchronizer and Data Decision

*CC2510Fx/CC2511Fx* contains an advanced and highly configurable demodulator. Channel filtering and frequency offset compensation is performed digitally. To generate the RSSI level (see section 15.10.3 for more information) the signal level in the channel is estimated. Data filtering is also included for enhanced performance.

#### 15.7.1 Frequency Offset Compensation

When using FSK or MSK modulation, the demodulator will compensate for the offset between the transmitter and receiver frequency, within certain limits, by estimating the centre of the received data.

This value is available in the `FREQEST` status register.

By issuing the `SAFC` command strobe, the measured frequency offset, `FREQEST.FREQOFF_EST`, can automatically be used to adjust the frequency offset programming in the frequency synthesizer. This will add the current RX frequency offset estimate to the value in `FSCTRL0.FREQOFF`, which adjust the synthesizer frequency. Thus, the frequency offset will be compensated in both RX and TX when the `SAFC` command strobe is used.

To avoid compensating for frequency offsets measured without a valid signal in the RF channel, `FREQEST.FREQOFF_EST` is copied to an internal register when issuing the `SAFC` strobe in RX, and when a sync word is detected. If `SAFC` was issued in RX, this internal value is added to `FSCTRL0.FREQOFF` after exiting RX. Issuing `SAFC` when not in RX will immediately add the internal register value to `FSCTRL0.FREQOFF`. Thus, the `SAFC` strobe should be issued when currently receiving a packet, or outside the RX state.

Note that frequency offset compensation is not supported for OOK modulation.

### 15.7.2 Bit Synchronization

The bit synchronization algorithm extracts the clock from the incoming symbols. The algorithm requires that the expected data rate is programmed as described in Section 15.5 on page 196. Re-synchronization is performed continuously to adjust for error in the incoming symbol rate.

### 15.7.3 Byte synchronization

Byte synchronization is achieved by a

## 15.8 Packet Handling Hardware Support

The **CC2510Fx/CC2511Fx** has built-in hardware support for packet oriented radio protocols.

In transmit mode, the packet handler will add the following elements to the packet stored to be transmitted:

- A programmable number of preamble bytes. Four preamble bytes are recommended.
- A two byte Synchronization Word. Can be duplicated to give a 4-byte sync word. (Recommended).
- Optionally whiten the data with a PN9 sequence.
- Optionally Interleave and Forward Error Code the data.

continuous sync word search. The sync word is a 16 or 32 bit configurable field that is automatically inserted at the start of the packet by the modulator in transmit mode. The demodulator uses this field to find the byte boundaries in the stream of bits. The sync word will also function as a system identifier, since only packets with the correct predefined sync word will be received. The sync word detector correlates against the user-configured 16-bit sync word. The correlation threshold can be set to 15/16 bits match or 16/16 bits match. The sync word can be further qualified using the preamble quality indicator mechanism described below and/or a carrier sense condition. The sync word is programmed with `SYNC1` and `SYNC0`.

In order to make false detections of sync words less likely, a mechanism called preamble quality indication (PQI) can be used to qualify the sync word. A threshold value for the preamble quality must be exceeded in order for a detected sync word to be accepted. See section 15.10.2 on page 203 for more details.

- Optionally compute and add a CRC checksum over the data field.

In receive mode, the packet handling support will de-construct the data packet:

- Preamble detection.
- Sync word detection.
- Optional one byte address check.
- Optionally compute and check CRC.
- Optionally append two status bytes (see Table 59 and Table 60) with RSSI value, Link Quality Indication and CRC status.

Bit	Field name	Description
7:0	RSSI	RSSI value

**Table 59: Received packet status byte 1  
(first byte appended after the data)**

Bit	Field name	Description
7	CRC_OK	1: CRC for received data OK (or CRC disabled) 0: CRC error in received data
6:0	LQI	The Link Quality Indicator estimates how easily a received signal can be demodulated

**Table 60: Received packet status byte 2 (second byte appended after the data)**

Note that register fields that control the packet handling features should only be altered when *CC2510Fx/CC2511Fx* is in the IDLE state.

### 15.8.1 Data whitening

From a radio perspective, the ideal over the air data are random and DC free. This results in the smoothest power distribution over the occupied bandwidth. This also gives the control loops in the receiver uniform operation conditions (no data dependencies).

Real world data often contain long sequences of zeros and ones. Performance can then be improved by whitening the data before transmitting, and de-whitening in the receiver. With *CC2510Fx/CC2511Fx*, this can be done automatically by setting `PKTCTRL0.WHITE_DATA=1`. All data, except the preamble and the sync word, are then XOR-ed with a 9-bit pseudo-random (PN9) sequence before being transmitted.

At the receiver end, the data are XOR-ed with the same pseudo-random sequence. This way, the whitening is reversed, and the original data appear in the receiver.

Setting `PKTCTRL0.WHITE_DATA=1` is recommended for all uses, except when over-the-air compatibility with other systems is needed.

### 15.8.2 Packet format

The format of the data packet can be configured and consists of the following items:

- Preamble
- Synchronization word
- Length byte or constant programmable packet length
- Optional Address byte
- Payload
- Optional 2 byte CRC

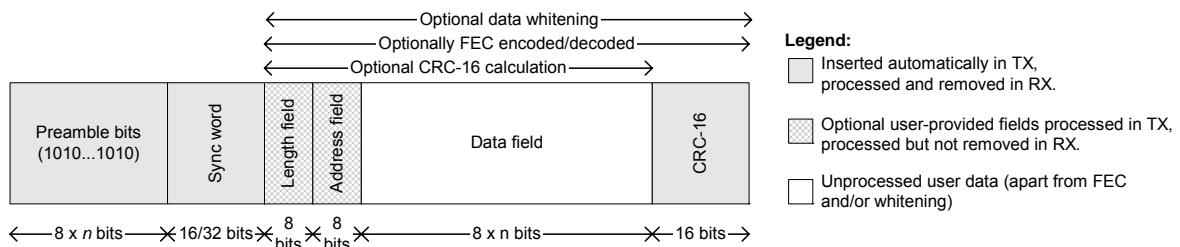

**Figure 46: Packet Format**

The preamble pattern is an alternating sequence of ones and zeros (01010101...). The minimum length of the preamble is programmable. When enabling TX, the modulator will start transmitting the preamble. When the programmed number of preamble bytes has been transmitted, the modulator will send the sync word and then data from the RFD register.

The number of preamble bytes is programmed with the `MDMCFG1.NUM_PREAMBLE` value.

The synchronization word is a two-byte value set in the `SYNC1` and `SYNC0` registers. The sync word provides byte synchronization of the incoming packet. A one-byte sync word can be emulated by setting the `SYNC1` value to the preamble pattern. It is also possible to emulate a 32 bit sync word by using `MDMCFG2.SYNC_MODE=3` or `7`. The sync word will then be repeated twice.

*CC2510Fx/CC2511Fx* supports both fixed packet length protocols and variable length protocols. The maximum packet length is 255 bytes. For longer packets, infinite packet length mode must be used.

Fixed packet length mode is selected by setting `PKTCTRL0.LENGTH_CONFIG=0`. The desired packet length is set by the `PKTLEN` register.

In variable packet length mode, `PKTCTRL0.LENGTH_CONFIG=1`, the packet length is configured by the first byte after the sync word. The packet length is defined as the payload data, excluding the length byte and the optional automatic CRC. The `PKTLEN` register is used to set the maximum packet length allowed in RX. Any packet received with a length byte with a value greater than `PKTLEN` will be discarded.

With `PKTCTRL0.LENGTH_CONFIG=2`, the packet length is set to infinite and transmission and reception will continue until turned off manually. The infinite mode can be turned off while a packet is being transmitted or received. As described in the next section, this can be used to support packet formats with different length configuration than natively supported by *CC2510Fx/CC2511Fx*.



15.8.2.1 Arbitrary length field configuration

The fixed length field can be reprogrammed during receive and transmit. This opens the possibility to have a different length field configuration than supported for variable length packets. At the start of reception, the packet length is set to a large value. The CPU reads out enough bytes to interpret the length field in the packet. Then the PKTLEN value is set according to this value. The end of packet will occur when the byte counter in the packet handler is equal to the PKTLEN register. Thus, the CPU must be able to program the correct length, before the internal counter reaches the packet length.

By utilizing the infinite packet length option, arbitrary packet length is available. At the start of the packet, the infinite mode must be active. On the TX side, the PKTLEN register is set to  $\text{mod}(\text{length}, 256)$ . On the RX side the MCU reads out enough bytes to interpret the length field in the packet and sets the PKTLEN register to  $\text{mod}(\text{length}, 256)$ . When less than 256 bytes remains of the packet the MCU

disables infinite packet length and activates fixed length packets. When the internal byte counter reaches the PKTLEN value, the transmission or reception ends. Automatic CRC appending/checking can be used (by setting PKTCTRL0.CRC\_EN to 1)

When for example a 600-byte packet is to be transmitted, the MCU should do the following (see also Figure 47):

- Set PKTCTRL0.LENGTH\_CONFIG=2 (10).
- Pre-program the PKTLEN register to  $\text{mod}(600,256)=88$ .
- Transmit at least 345 bytes.
- Set PKTCTRL0.LENGTH\_CONFIG=0 (00).
- The transmission ends when the packet counter reaches 88. A total of 600 bytes are transmitted.

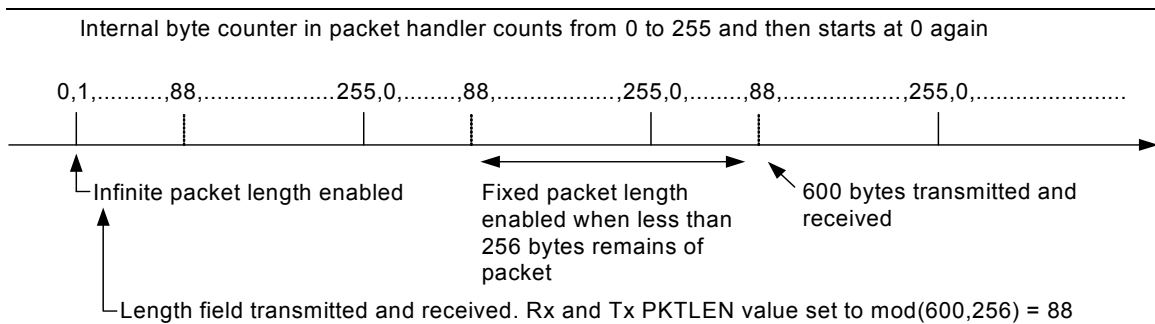

Figure 47: Arbitrary length field configuration

### 15.8.3 Packet filtering in Receive Mode

**CC2510Fx/CC2511Fx** supports two different packet-filtering criteria: address filtering and maximum length filtering.

#### 15.8.3.1 Address Filtering

Setting `PKTCTRL1.ADR_CHK` to any other value than zero enables the packet address filter. The packet handler engine will compare the destination address byte in the packet with the programmed node address in the `ADDR` register and the `0x00` broadcast address when `PKTCTRL1.ADR_CHK=10` or both `0x00` and `0xFF` broadcast addresses when `PKTCTRL1.ADR_CHK=11`. If the received address matches a valid address, the packet is accepted and a `RFTXR` interrupt and a DMA trigger is generated. If the address match fails, the packet is discarded and receive mode restarted (regardless of the `MCSM1.RXOFF_MODE` setting). If the received address matches a valid address when the packet length is set to infinite and address filtering is enabled, the first byte read from the radio will be `0xFF`, followed by the address byte and then the payload data.

#### 15.8.3.2 Maximum Length Filtering

In the variable packet length mode the `PKTLEN.PACKET_LENGTH` register value is used to set the maximum allowed packet length. If the received length byte has a larger value than this, the packet is discarded and receive mode restarted (regardless of the `MCSM1.RXOFF_MODE` setting).

### 15.8.4 Packet Handling in Transmit Mode

The payload that is to be transmitted must be written into `RFD`. The first byte written must be the length byte when variable packet length is enabled. The length byte has a value equal to the payload of the packet (including the optional address byte). If fixed packet length is enabled, then the first byte written to `RFD` is interpreted as the destination address, if this feature is enabled in the device that receives the packet.

The modulator will first send the programmed number of preamble bytes. If data is written to `RFD`, the modulator will send the two-byte (optionally 4-byte) sync word and then the payload written to `RFD`. If CRC is enabled, the checksum is calculated over all the data pulled

from `RFD` and the result is sent as two extra bytes at the end of the payload data.

If whitening is enabled, the length byte, payload data and the two CRC bytes will be whitened. This is done before the optional FEC/Interleaver stage. Whitening is enabled by setting `PKTCTRL0.WHITE_DATA=1`.

If FEC/Interleaving is enabled, the length byte, payload data and the two CRC bytes will be scrambled by the interleaver, and FEC encoded before being modulated.

### 15.8.5 Packet Handling in Receive Mode

In receive mode, the demodulator and packet handler will search for a valid preamble and the sync word. When found, the demodulator has obtained both bit and byte synchronism and will receive the first payload byte.

If FEC/Interleaving is enabled, the FEC decoder will start to decode the first payload byte. The interleaver will de-scramble the bits before any other processing is done to the data.

If whitening is enabled, the data will be de-whitened at this stage.

When variable packet length is enabled, the first byte is the length byte. The packet handler stores this value as the packet length and receives the number of bytes indicated by the length byte. If fixed packet length is used, the packet handler will accept the programmed number of bytes.

Next, the packet handler optionally checks the address and only continues the reception if the address matches. If automatic CRC check is enabled, the packet handler computes CRC and matches it with the appended CRC checksum.

At the end of the payload, the packet handler will optionally write two extra packet status bytes that contain CRC status, link quality indication and RSSI value.

## 15.9 Modulation Formats

**CC2510Fx/CC2511Fx** supports amplitude, frequency and phase shift modulation formats. The desired modulation format is set in the `MDMCFG2.MOD_FORMAT` register.

Optionally, the data stream can be Manchester coded by the modulator and decoded by the demodulator. This option is enabled by setting `MDMCFG2.MANCHESTER_EN=1`. Manchester

encoding is not supported at the same time as using the FEC/Interleaver option.

### 15.9.1 Frequency Shift Keying

2-FSK can optionally be shaped by a Gaussian filter with BT=1, producing a GFSK modulated signal.

The frequency deviation is programmed with the DEVIATION\_M and DEVIATION\_E values in the DEVIATN register. The value has an exponent/mantissa form, and the resultant deviation is given by:

$$f_{dev} = \frac{f_{xosc}}{2^{17}} \cdot (8 + DEVIATION\_M) \cdot 2^{DEVIATION\_E}$$

The symbol encoding is shown in Table 61.

Format	Symbol	Coding
2FSK/GFSK	'0'	- Deviation
	'1'	+ Deviation

**Table 61: Symbol encoding for FSK modulation**

### 15.9.2 Minimum Shift Keying

When using MSK<sup>6</sup>, the complete transmission (preamble, sync word and payload) will be MSK modulated.

Phase shifts are performed with a constant transition time.

The fraction of a symbol period used to change the phase can be modified with the DEVIATN.DEVIATION\_M setting. This is equivalent to changing the shaping of the symbol.

The MSK modulation format implemented in CC2510Fx/CC2511Fx inverts the sync word and data compared to e.g. signal generators.

<sup>6</sup> Identical to offset QPSK with half-sine shaping (data coding may differ)

Another use of the preamble quality threshold is as a qualifier for the optional RX termination timer. See section 15.12.3 on page 210 for details.

The preamble quality estimator increases an internal counter by one each time a bit is received that is different from the previous bit,

### 15.9.3 Amplitude Modulation

The supported amplitude modulation On-Off Keying (OOK) simply turns on or off the PA to modulate 1 and 0 respectively.

## 15.10 Received Signal Qualifiers and Link Quality Information

CC2510Fx/CC2511Fx has several qualifiers that can be used to increase the likelihood that a valid sync word is detected.

### 15.10.1 Sync Word Qualifier

If sync word detection in RX is enabled in register MDMCFG2 the CC2510Fx/CC2511Fx will not start writing received data to the RFD register and perform the packet filtering described in section 15.8.3 before a valid sync word has been detected. The sync word qualifier mode is set by MDMCFG2.SYNC\_MODE and is summarized in Table 62. Carrier sense in Table 62 is described in section 15.10.4

MDMCFG2.SYNC_MODE	Sync word qualifier mode
000	No preamble/sync
001	15/16 sync word bits detected
010	16/16 sync word bits detected
011	30/32 sync word bits detected
100	No preamble/sync, carrier sense above threshold
101	15/16 + carrier sense above threshold
110	16/16 + carrier sense above threshold
111	30/32 + carrier sense above threshold

**Table 62: Sync word qualifier mode**

### 15.10.2 Preamble Quality Threshold (PQT)

The Preamble Quality Threshold (PQT) sync-word qualifier adds the requirement that the received sync word must be preceded with a preamble with a quality above the programmed threshold.

and decreases the counter by 4 each time a bit is received that is the same as the last bit. The counter saturates at 0 and 31. The threshold is configured with the register field PKTCTRL1.PQT. A threshold of 4·PQT for this counter is used to gate sync word detection.

By setting the value to zero, the preamble quality qualifier of the sync word is disabled.

A "Preamble Quality reached" flag can also be observed in the status register bit `PKTSTATUS.PQT_REACHED`. This flag asserts when the received signal exceeds the PQT.

### 15.10.3 RSSI

The RSSI value is an estimate of the signal level in the chosen channel. This value is based on the current gain setting in the RX chain and the measured signal level in the channel.

In RX mode, the RSSI value can be read continuously from the RSSI status register. The RSSI value is in dB with 1/2dB resolution. The RSSI update rate depends on the receiver filter bandwidth ( $BW_{channel}$  defined in Section **Error! Reference source not found.**) and `AGCCTRL0.FILTER_LENGTH`.

$$f_{RSSI} = \frac{2 \cdot BW_{channel}}{8.2 \cdot FILTER\_LENGTH}$$

If `PKTCTRL1.APPEND_STATUS` is enabled the last RSSI value of the packet is automatically added to the first byte appended after the data.

The RSSI value read from the RSSI status register is a 2's complement number. The following procedure can be used to convert the RSSI reading to an absolute power level (RSSI\_dBm).

- 1) Read the RSSI status register
- 2) Convert the reading from a hexadecimal number to a decimal number (RSSI\_dec)
- 3) If  $RSSI\_dec \geq 128$  then  $RSSI\_dBm = (RSSI\_dec - 256)/2 - RSSI\_offset$
- 4) Else if  $RSSI\_dec < 128$  then  $RSSI\_dBm = (RSSI\_dec)/2 - RSSI\_offset$

**Error! Reference source not found.** Table 63 gives typical values for the `RSSI_offset`. Figure 48 shows typical plots of RSSI reading as a function of input power level for different data rates.

Data rate	RSSI_offset (decimal)
2.4 kbps	71
10 kbps	69
250 kbps	72
500 kbps	72

Table 63: Typical RSSI\_offset values

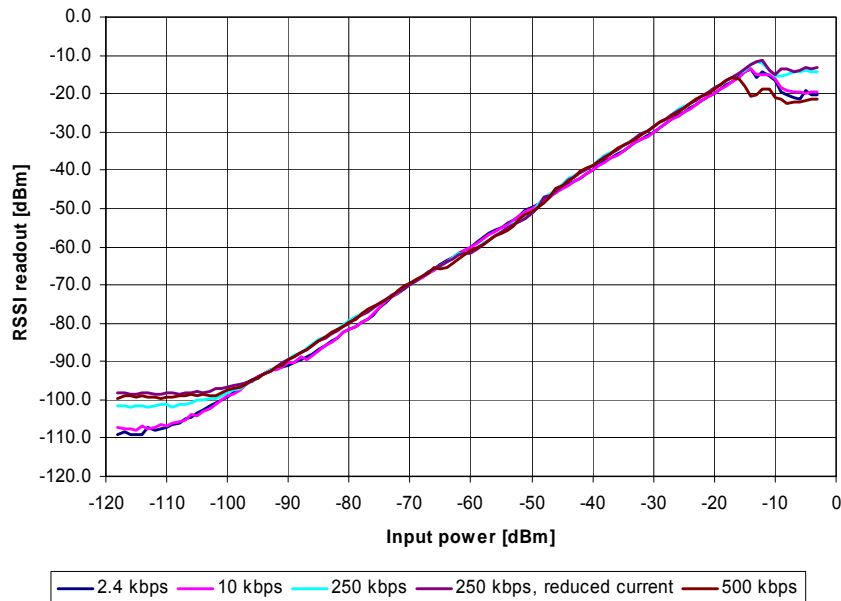

Figure 48: Typical RSSI value vs. input power level for some typical data rates

#### 15.10.4 Carrier Sense (CS)

The Carrier Sense flag is used as a sync word qualifier and for CCA. The CS flag can be set based on two conditions, which can be individually adjusted:

- CS is asserted when the RSSI is above a programmable absolute threshold, and de-asserted when RSSI is below the same threshold (with hysteresis).
- CS is asserted when the RSSI has increased with a programmable number of dB from one RSSI sample to the next, and de-asserted when RSSI has decreased with the same number of dB. This setting is not dependent on the absolute signal level and is thus useful to detect signals in environments with time varying noise floor.

Carrier Sense (CS) can be used as a sync word qualifier that requires the signal level to be higher than the threshold for a sync word search to be performed. The signal can also be observed in the status register bit `PKTSTATUS.CS`.

Other uses of Carrier Sense include the TX-If-CCA function (see section 15.10.7

on page 206) and the optional fast RX termination (see section 15.12.3 on page 210 for details.).

CS can be used to avoid interference from e.g. WLAN.

#### 15.10.5 CS Absolute Threshold

The absolute threshold related to the RSSI value is given by:

$$THR_{RSSI} = MAGN\_TARGET + CARRIER\_SENSE\_ABS\_THR - GAIN_{MAX}$$

The maximum possible gain can be reduced using the `AGCCTRL2.MAX_LNA_GAIN` and `AGCCTRL2.MAX_DVGA_GAIN` register fields. `CARRIER_SENSE_ABS_THR` is programmable in 1 dB steps from -7 dB to +7 dB. Table 64 and Table 65 show the RSSI readout values at the CS threshold at 2.4 kbps and 250 kbps data rate respectively. The default `CARRIER_SENSE_ABS_THR = 0` (0 dB) and `MAGN_TARGET = 3` (33 dB) have been used.

		MAX_DVGA_GAIN[1:0]			
		00	01	10	11
MAX_LNA_GAIN[2:0]	000	-99	-93	-87	-81.5
	001	-97	-90.5	-85	-78.5
	010	-93.5	-87	-82	-76
	011	-91.5	-86	-80	-74
	100	-90.5	-84	-78	-72.5
	101	-88	-82.5	-76	-70
	110	-84.5	-78.5	-73	-67
	111	-82.5	-76	-70	-64

Table 64: Typical RSSI value in dBm at CS threshold with default MAGN\_TARGET at 2.4 kbps

		MAX_DVGA_GAIN[1:0]			
		00	01	10	11
MAX_LNA_GAIN[2:0]	000	-96	-90	-84	-78.5
	001	-94.5	-89	-83	-77.5
	010	-92.5	-87	-81	-75
	011	-91	-85	-78.5	-73
	100	-87.5	-82	-76	-70
	101	-85	-79.5	-73.5	-67.5
	110	-83	-76.5	-70.5	-65
	111	-78	-72	-66	-60

Table 65: Typical RSSI value in dBm at CS threshold with default MAGN\_TARGET at 250 kbps

If the threshold is to be set high, e.g. only strong signals are wanted, the threshold should be adjusted upwards by first reducing the MAX\_LNA\_GAIN value and then the MAX\_DVGA\_GAIN value. This will reduce power consumption in the receiver front end, since the highest gain settings are avoided.

The MAGN\_TARGET setting is a compromise between blocker tolerance/selectivity and sensitivity. The value sets the desired signal level in the channel into the demodulator. Increasing this value reduces the headroom for blockers, and therefore close-in selectivity.

#### 15.10.6 CS relative threshold

The relative threshold detects sudden changes in the measured signal level. This setting is not dependent on the absolute signal level and is

thus useful to detect signals in environments with a time varying noise floor. The register field AGCCTRL1.CARRIER\_SENSE\_REL\_THR is used to enable/disable relative CS, and to select threshold of 6 dB, 10 dB or 14 dB RSSI change.

#### 15.10.7 Clear Channel Assessment (CCA)

The Clear Channel Assessment is used to indicate if the current channel is free or busy. The current CCA state is viewable in the PKTSTATUS register

MCSM1.CCA\_MODE selects the mode to use when determining CCA.

When the STX or SFSTXON command strobe is given while CC2510Fx/CC2511Fx is in the RX state, the TX state is only entered if the clear

channel requirements are fulfilled. The chip will otherwise remain in RX. This feature is called TX if CCA.

Four CCA requirements can be programmed:

- Always (CCA disabled, always goes to TX)
- If RSSI is below threshold
- Unless currently receiving a packet
- Both the above (RSSI below threshold and not currently receiving a packet)

### 15.10.8 Link Quality Indicator (LQI)

The Link Quality Indicator is a metric of the current quality of the received signal. If `PKTCTRL1.APPEND_STATUS` is enabled, the value is automatically appended to the end of each received packet. The value can also be read from the `LQI` status register. The LQI is calculated over the 64 symbols following the sync word (first 8 packet bytes). LQI is best used as a relative measurement of the link quality, since the value is dependent on the modulation format.

### 15.11 Forward Error Correction with Interleaving

*CC2510Fx/CC2511Fx* has built-in support for Forward Error Correction (FEC). To enable this option, set `MDMCFG1.FEC_EN` to 1. FEC is employed on the data field and CRC word in order to reduce the gross bit error rate when operating near the sensitivity limit. Redundancy is added to the transmitted data in such a way that the receiver can restore the original data in the presence of some bit errors.

The use of FEC allows correct reception at a lower SNR, thus extending communication range. Alternatively, for a given SNR, using FEC decreases the bit error rate (BER). As the packet error rate (PER) is related to BER by:

$$PER = 1 - (1 - BER)^{packet\_length}$$

a lower BER can be used to allow significantly longer packets, or a higher percentage of packets of a given length, to be transmitted successfully. Finally, in realistic ISM radio environments, transient and time-varying phenomena will produce occasional errors even in otherwise good reception conditions. FEC will mask such errors and, combined with interleaving of the coded data, even correct

relatively long periods of faulty reception (burst errors).

The FEC scheme adopted for *CC2510Fx/CC2511Fx* is convolutional coding, in which  $n$  bits are generated based on  $k$  input bits and the  $m$  most recent input bits, forming a code stream able to withstand a certain number of bit errors between each coding state (the  $m$ -bit window).

The convolutional coder is a rate 1/2 code with a constraint length of  $m=4$ . The coder codes one input bit and produces two output bits; hence, the effective data rate is halved.

#### 15.11.1 Interleaving

Data received through real radio channels will often experience burst errors due to interference and time-varying signal strengths. In order to increase the robustness to errors spanning multiple bits, interleaving is used when FEC is enabled. After de-interleaving, a continuous span of errors in the received stream will become single errors spread apart.

*CC2510Fx/CC2511Fx* employs matrix interleaving, which is illustrated in Figure 49. The on-chip interleaving and de-interleaving buffers are 4 x 4 matrices. In the transmitter, the data bits are written into the rows of the matrix, whereas the bit sequence to be transmitted is read from the columns of the matrix and fed to the rate 1/2 convolutional coder. Conversely, in the receiver, the received symbols are written into the columns of the matrix, whereas the data passed onto the convolutional decoder is read from the rows of the matrix.

When FEC and interleaving is used at least one extra byte is required for trellis termination. In addition, the amount of data transmitted over the air must be a multiple of the size of the interleaver buffer (two bytes). The packet control hardware therefore automatically inserts one or two extra bytes at the end of the packet, so that the total length of the data to be interleaved is an even number. Note that these extra bytes are invisible to the user, as they are removed before the received packet enters the `RFD` data register.

When FEC and interleaving is used the minimum data payload is 2 bytes in fixed and variable packet length mode.

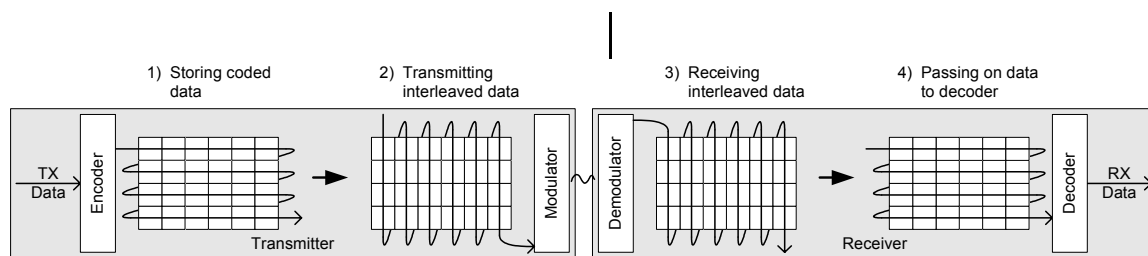

Figure 49: General principle of matrix interleaving

### 15.12 Radio Control

CC2510Fx/CC2511Fx has a built-in state machine that is used to switch between different operation states (modes). The change of state is done by using command strobes.

A simplified state diagram, together with typical usage and current consumption, is

shown in Figure 43 on page 192. The complete radio control state diagram is shown in Figure 50. The numbers refer to the state number readable in the MARCSTATE status register. This register is primarily for test purposes.



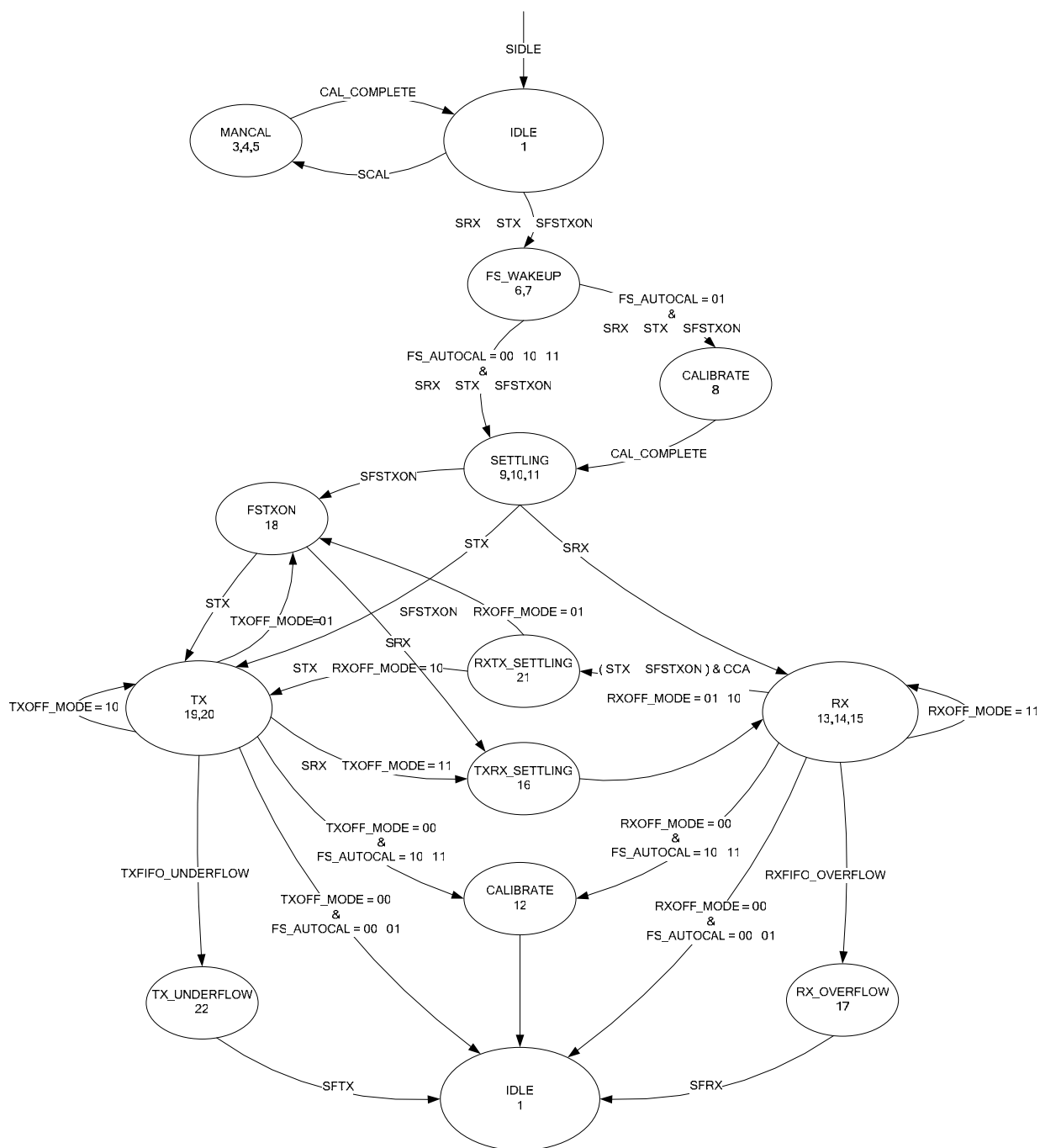

Figure 50: Complete Radio Control State Diagram

### 15.12.1 Active Modes

The *CC2510Fx/CC2511Fx* radio has two active modes: receive and transmit. These modes are activated directly by the CPU by writing the SRX and STX command strobes to the RFST register.

The frequency synthesizer must be calibrated regularly. *CC2510Fx/CC2511Fx* has one manual calibration option (using the SCAL strobe), and

three automatic calibration options. The automatic calibration options are controlled by the MCSM0.FS\_AUTOCAL setting:

- Calibrate when going from IDLE to either RX or TX (or FSTXON)
- Calibrate when going from either RX or TX to IDLE

- Calibrate every fourth time when going from either RX or TX to IDLE

The calibration takes a constant number of XOSC cycles (see Table 66 for timing details).

When RX is activated, the chip will remain in receive mode until the RX termination timer expires (see section 15.12.3) or a packet has been successfully received. Note: the probability that a false sync word is detected can be reduced by using PQT, CS, maximum sync word length and sync word qualifier mode as describe in section 15.10. After a packet is successfully received the radio controller will then go to the state indicated by the `MCSM1.RXOFF_MODE` setting. The possible states are:

- IDLE
- FSTXON: Frequency synthesizer on and ready at the TX frequency. Activate TX with `STX`.
- TX: Start sending preambles
- RX: Start search for a new packet

Similarly, when TX is active the chip will remain in the TX state until the current packet has been successfully transmitted. Then the state will change as indicated by the `MCSM1.TXOFF_MODE` setting. The possible destinations are the same as for RX.

The CPU can change the state from RX to TX and vice versa by using the command strobes. If the radio controller is currently in transmit and the `SRX` strobe is written, the current transmission will be ended and the transition to RX will be done.

If the radio controller is in RX when the `STX` or `SFSTXON` command strobes are issued, the “TX if clear channel” function will be used. If the channel is not clear, the chip will remain in RX. The `MCSM1.CCA_MODE` setting controls the conditions for clear channel assessment. See section 15.10.7 on page 206 for details.

The `SIDLE` command strobe can always be issued to force the radio controller to go to the IDLE state.

### 15.12.2 Timing

The radio controller controls most timing in *CC2510Fx/CC2511Fx*, such as synthesizer calibration, PLL lock and RT/TX turnaround times. Timing from IDLE to RX and IDLE to TX is constant, dependent on the auto calibration

setting. RX/TX and TX/RX turnaround times are constant. The calibration time is constant 18739 clock periods. Table 66 shows timing in crystal clock cycles for key state transitions.

Power on time and XOSC start-up times are variable, but within the limits stated in Table 9. Note that in a frequency hopping spread spectrum or a multi-channel protocol the calibration time can be reduced from 721  $\mu$ s to approximately 150  $\mu$ s. This is explained in section 15.18.2.

Description	XOSC periods	26MHz crystal
Idle to RX, no calibration	2298	88.4 $\mu$ s
Idle to RX, with calibration	~21037	809 $\mu$ s
Idle to TX/FSTXON, no calibration	2298	88.4 $\mu$ s
Idle to TX/FSTXON, with calibration	~21037	809 $\mu$ s
TX to RX switch	560	21.5 $\mu$ s
RX to TX switch	250	9.6 $\mu$ s
RX or TX to IDLE, no calibration	2	0.1 $\mu$ s
RX or TX to IDLE, with calibration	~18739	721 $\mu$ s
Manual calibration	~18739	721 $\mu$ s

Table 66: State transition timing

### 15.12.3 RX Termination Timer

*CC2510Fx/CC2511Fx* has optional functions for automatic termination of RX after a programmable time. The termination timer starts when enabling the demodulator. The timeout is programmable with the `MCSM2.RX_TIME` setting. When the timer expires, the radio controller will check the condition for staying in RX; if the condition is not met, RX will terminate. After the timeout, the condition will be checked continuously.

The programmable conditions are:

- `MCSM2.RX_TIME_QUAL=0`: Continue receive if sync word has been found
- `MCSM2.RX_TIME_QUAL=1`: Continue receive if sync word has been found or preamble quality is above threshold (PQT)

If the system can expect the transmission to have started when enabling the receiver, the `MCSM2.RX_TIME_RSSI` function can be used. The radio controller will then terminate RX if the first valid carrier sense sample indicates no carrier (RSSI below threshold). See Section

15.10.4 on page 205 for details on Carrier Sense.

For OOK modulation, lack of carrier sense is only considered valid after eight symbol periods. Thus, the `MCSM2.RX_TIME_RSSI` function can be used in OOK mode when the distance between “1” symbols is 8 or less.

If RX terminates due to no carrier sense when the `MCSM2.RX_TIME_RSSI` function is used, or if no sync word was found when using the `MCSM2.RX_TIME` timeout function, the chip will always go back to IDLE. Otherwise, the `MCSM1.RXOFF_MODE` setting determines the state to go to when RX ends.

## 15.13 Frequency Programming

The frequency programming in *CC2510Fx/CC2511Fx*

$$f_{\text{carrier}} = \frac{f_{\text{XOSC}}}{2^{16}} \cdot \left( \text{FREQ} + \text{CHAN} \cdot \left( (256 + \text{CHANSPC\_M}) \cdot 2^{\text{CHANSPC\_E}-2} \right) \right)$$

With a 26 MHz crystal the maximum channel spacing is 405 kHz. To get e.g. 1 MHz channel spacing one solution is to use 333 kHz channel spacing and select each third channel in `CHANNR.CHAN`.

The preferred IF frequency is programmed with the `FSCTRL1.FREQ_IF` register. The IF frequency is given by:

$$f_{\text{IF}} = \frac{f_{\text{XOSC}}}{2^{10}} \cdot \text{FREQ\_IF}$$

Note that the SmartRF® Studio software automatically calculates the optimum `FSCTRL1.FREQ_IF` register setting based on channel spacing and channel filter bandwidth.

If any frequency programming register is altered when the frequency synthesizer is running, the synthesizer may give an undesired response. Hence, the frequency programming should only be updated when the radio is in the IDLE state.

## 15.14 VCO

The VCO is completely integrated on-chip.

is designed to minimize the programming needed in a channel-oriented system.

To set up a system with channel numbers, the desired channel spacing is programmed with the `MDMCFG0.CHANSPC_M` and `MDMCFG1.CHANSPC_E` registers. The channel spacing registers are mantissa and exponent respectively.

The base or start frequency is set by the 24 bit frequency word located in the `FREQ2`, `FREQ1` and `FREQ0` registers. This word will typically be set to the centre of the lowest channel frequency that is to be used.

The desired channel number is programmed with the 8-bit channel number register, `CHANNR.CHAN`, which is multiplied by the channel offset. The resultant carrier frequency is given by:

### 15.14.1 VCO and PLL Self-Calibration

The VCO characteristics will vary with temperature and supply voltage changes, as well as the desired operating frequency. In order to ensure reliable operation, *CC2510Fx/CC2511Fx* includes frequency synthesizer self-calibration circuitry. This calibration should be done regularly, and must be performed after turning on power and before using a new frequency (or channel). The number of XOSC cycles for completing the PLL calibration is given in Table 66 on page 210.

The calibration can be initiated automatically or manually. The synthesizer can be automatically calibrated each time the synthesizer is turned on, or each time the synthesizer is turned off. This is configured with the `MCSM0.FS_AUTOCAL` register setting. In manual mode, the calibration is initiated when the `SCAL` command strobe is activated in the IDLE mode.

Note that the calibration values are maintained in power-down modes PM2/3, so the calibration is still valid after waking up from these power-down modes (unless supply voltage or temperature has changed significantly).

### 15.15 Output Power Programming

The RF output power level from the device has two levels of programmability, as illustrated in Figure 51. Firstly, the PA\_TABLE7-PA\_TABLE0 registers can hold up to eight user selected output power settings. Secondly, the 3-bit FRENDO.PA\_POWER value selects which PA\_TABLE7-0 register to use. This two-level functionality provides flexible PA power ramp up and ramp down at the start and end of transmission. In each case, all the PA power settings from PA\_TABLE from index 0 up to the FRENDO.PA\_POWER value are used.

The power ramping at the start and at the end of a packet can be turned off by setting FRENDO.PA\_POWER to zero and then programming the desired output power in PA\_TABLE0.

Table 67 contains recommended PA\_TABLE settings for various output levels and frequency bands, together with current consumption in the RF transceiver.

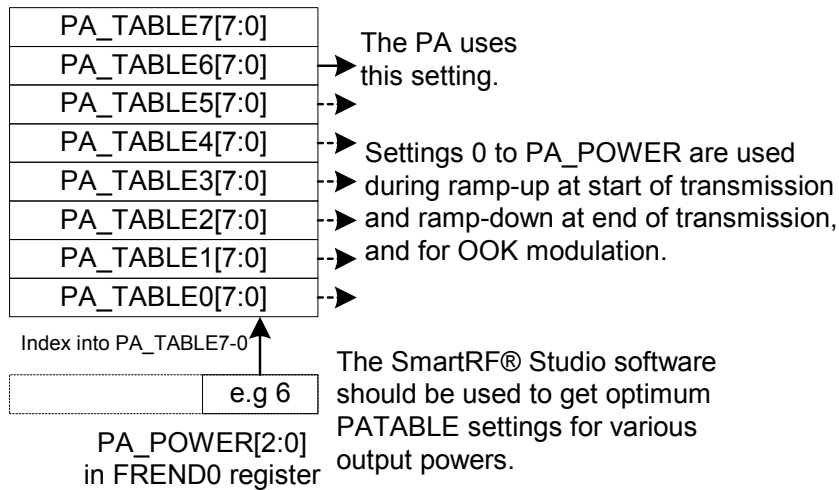

Figure 51: PA\_POWER and PA\_TABLE7-0

Output power [dBm] Typical +25 °C, 3.0 V	Setting	Current consumption, typ. [mA]
(-55 or less)	0x00	8.9
-30	0x44	10.1
-28	0x41	10.0
-26	0x4C	11.7
-24	0x53	11.1
-22	0x83	10.9
-20	0x46	10.5
-18	0x4A	11.7
-16	0x86	11.0
-14	0x66	12.9
-12	0xC6	11.5
-10	0x69	14.1
-8	0x99	13.6
-6	0x7F	15.4
-4	0xAA	16.7
-2	0xBF	18.5
0	0xFB	21.6
1	0xFF	21.9

Table 67: Optimum PA\_TABLE settings for various output power levels (subject to changes)

### 15.16 Selectivity Graphs

Figure 52 to Figure 56 show the typical selectivity performance (adjacent and alternate rejection).

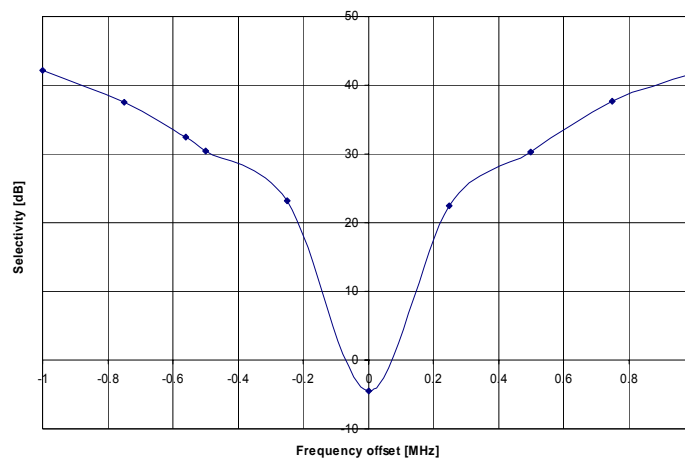

Figure 52: Typical selectivity at 2.4 kbps. IF frequency is 273.9 kHz.  
MDMCFG2.DEM\_DCFILT\_OFF = 1

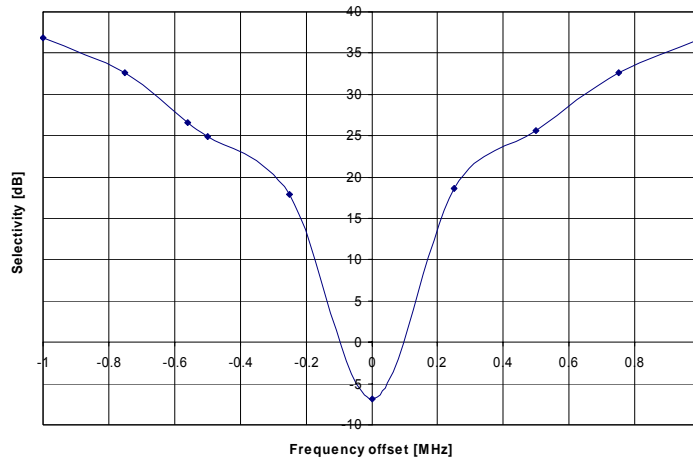

Figure 53: Typical selectivity at 10 kbps. IF frequency is 273.9 kHz.  
MDMCFG2.DEM\_DCFILT\_OFF = 1

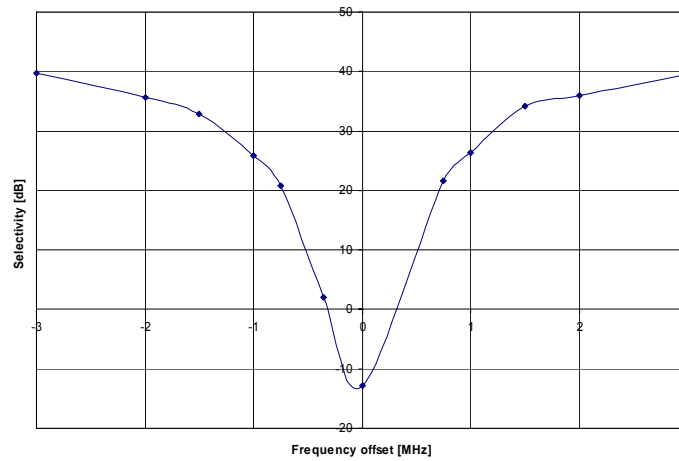

Figure 54: Typical selectivity at 250 kbps. IF frequency is 177.7 kHz.  
MDMCFG2.DEM\_DCFILT\_OFF = 0

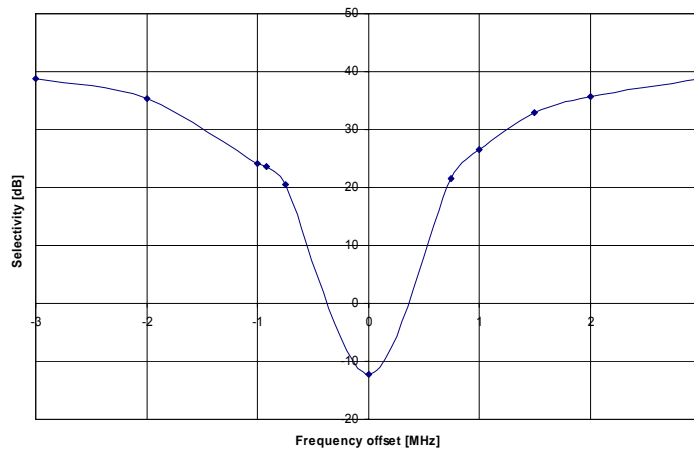

Figure 55: Typical selectivity at 250 kbps. IF frequency is 457 kHz.  
MDMCFG2.DEM\_DCFILT\_OFF = 1

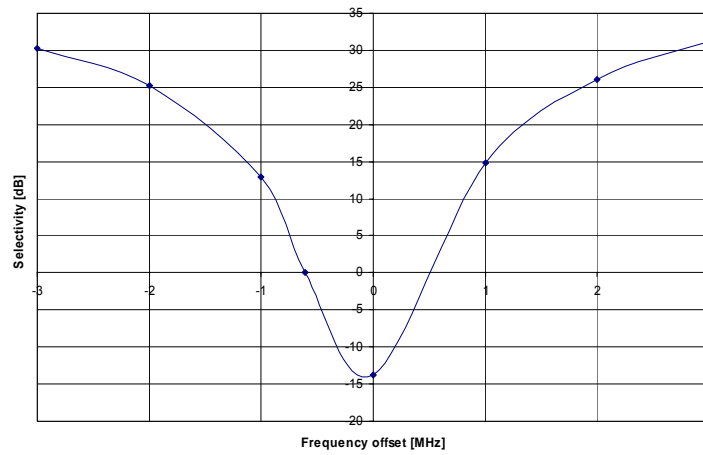

Figure 56: Typical selectivity at 500 kbps. IF frequency is 307.4 kHz.  
MDMCFG2.DEM\_DCFILT\_OFF = 0

## 15.17 Antenna Interface

The balanced RF input and output of *CC2510Fx/CC2511Fx* share two common pins and are designed for a simple, low-cost matching and balun network on the printed circuit board. The receive- and transmit switching at the *CC2510Fx/CC2511Fx* front-end is controlled by a dedicated on-chip function, eliminating the need for an external RX/TX-switch.

A few passive external components combined with the internal RX/TX switch/termination circuitry ensures match in both RX and TX mode.

Although *CC2510Fx/CC2511Fx* has a balanced RF input/output, the chip can be connected to a single-ended antenna with few external low cost capacitors and inductors.

The passive matching/filtering network connected to *CC2510Fx/CC2511Fx* should have the following differential impedance as seen from the RF-port (RF\_P and RF\_N) towards the antenna:

$$Z_{out} = 80 + j74 \Omega$$

To ensure optimal matching of the *CC2510Fx/CC2511Fx* differential output it is recommended to follow the CC2510EM reference designs as closely as possible. Gerber files for the reference designs are available for download from the Chipcon website.

## 15.18 System considerations and Guidelines

### 15.18.1 SRD Regulations

International regulations and national laws regulate the use of radio receivers and transmitters. Short Range Devices (SRDs) for license free operation are allowed to operate in the 2.45 GHz bands worldwide. The most important regulations are EN 300 440 and EN 300 328 (Europe), FCC CFR47 part 15.247 and 15.249 (USA), and ARIB STD-T66 (Japan). A summary of the most important aspects of these regulations can be found in Application Note *AN032 SRD regulations for license-free transceiver operation in the 2.4 GHz band*, available from the Chipcon website.

Please note that compliance with regulations is dependent on complete system

performance. It is the customer's responsibility to ensure that the system complies with regulations.

### 15.18.2 Frequency Hopping and Multi-Channel Systems

The 2.400 – 2.4835 GHz band is shared by many systems both in industrial, office and home environments. It is therefore recommended to use frequency hopping spread spectrum (FHSS) or a multi-channel protocol because the frequency diversity makes the system more robust with respect to interference from other systems operating in the same frequency band. FHSS also combats multipath fading.

*CC2510Fx/CC2511Fx* is highly suited for FHSS or multi-channel systems due to its agile frequency synthesizer and effective communication interface. Using the packet handling support and data buffering is also beneficial in such systems as these features will significantly offload the host controller.

Charge pump current, VCO current and VCO capacitance array calibration data is required for each frequency when implementing frequency hopping for *CC2510Fx/CC2511Fx*. There are 3 ways of obtaining the calibration data from the chip:

- 1) Frequency hopping with calibration for each hop. The PLL calibration time is approximately 720  $\mu$ s.
- 2) Fast frequency hopping without calibration for each hop can be done by calibrating each frequency at startup and saving the resulting FSCAL3, FSCAL2 and FSCAL1 register values in MCU memory. Between each frequency hop, the calibration process can then be replaced by writing the FSCAL3, FSCAL2 and FSCAL1 register values corresponding to the next RF frequency. The PLL turn on time is approximately 90  $\mu$ s.
- 3) Run calibration on a single frequency at startup. Next write 0hex to FSCAL3[5:4] to disable the charge pump calibration. After writing to FSCAL3[5:4] strobe SRX (or STX) with MCSM0.FS\_AUTOCAL = 1 for each new frequency hop. That is, VCO current and VCO capacitance calibration is done but not charge pump current calibration. When charge pump current calibration is disabled the calibration time is reduced from approximately 720  $\mu$ s to approximately 150  $\mu$ s.



There is a trade off between blanking time and memory space needed for storing calibration data in non-volatile memory. Solution 2) above gives the shortest blanking interval, but requires more memory space to store calibration values. Solution 3) gives approximately 570  $\mu$ s smaller blanking interval than solution 1).

#### 15.18.3 Wideband Modulation not Using Spread Spectrum

Digital modulation systems under FCC part 15.247 includes FSK and GFSK modulation. A maximum peak output power of +30 dBm is allowed if the 6 dB bandwidth of the modulated signal is not less than 500 kHz. In addition, the peak power spectral density conducted to the antenna shall not be greater than +8 dBm in any 3 kHz band.

Operating at high data rates and high frequency separation, the **CC2500** is suited for systems targeting compliance with digital modulation system as defined by FCC part 15.247. An external power amplifier is needed to increase the output above +0 dBm.

#### 15.18.4 Data Burst Transmissions

The high maximum data rate of **CC2510Fx/CC2511Fx** opens up for burst transmissions. A low average data rate link (say 10 kbps), can be realized using a higher over-the-air data rate. Buffering the data and transmitting in bursts at high data rate (say 500 kbps) will reduce the time in active mode, and hence also reduce the average current consumption significantly. Reducing the time in active mode will reduce the likelihood of collisions with other systems, e.g. WLAN.

#### 15.18.5 Continuous Transmissions

In data streaming applications the **CC2510Fx/CC2511Fx** opens up for continuous transmissions at 500 kbps effective data rate. As the modulation is done with an I/Q up-converter with LO I/Q-signals coming from a closed loop PLL, there is no limitation in the length of a transmission. (Open loop modulation used in some transceivers often prevents this kind of continuous data streaming and reduces the effective data rate.)

#### 15.18.6 Crystal Drift Compensation

The **CC2510Fx/CC2511Fx** has a very fine frequency resolution. This feature can be used to compensate for frequency offset and drift.

The frequency offset between an 'external' transmitter and the receiver is measured in the **CC2510Fx/CC2511Fx** and can be read back from the `FREQEST` status register. The measured frequency offset can be used to calibrate the frequency using the 'external' transmitter as the reference. That is, the received signal of the device will match the receiver's channel filter better. In the same way the centre frequency of the transmitted signal will match the 'external' transmitter's signal.

#### 15.18.7 Spectrum Efficient Modulation

**CC2510Fx/CC2511Fx** also has the possibility to use Gaussian shaped FSK (GFSK). This spectrum-shaping feature improves adjacent channel power (ACP) and occupied bandwidth. In 'true' FSK systems with abrupt frequency shifting, the spectrum is inherently broad. By making the frequency shift 'softer', the spectrum can be made significantly narrower. Thus, higher data rates can be transmitted in the same bandwidth using GFSK.

#### 15.18.8 Low Cost Systems

As the **CC2510Fx/CC2511Fx** provides 500 kbps multi-channel performance without any external filters, a very low cost system can be made.

A differential antenna will eliminate the need for a balun, and the DC biasing can be achieved in the antenna topology, see Figure 7.

A HC-49 type SMD crystal is used in the **CC2510Fx** EM reference design. Note that the crystal package strongly influences the price. In a size constrained PCB design a smaller, but more expensive, crystal may be used.

#### 15.18.9 Battery Operated Systems

In low power applications, the low power modes PM2 or PM3 with should be used when the **CC2510Fx/CC2511Fx** is not active.

The Sleep Timer Wake-on-Radio functionality should be used in low power applications.

#### 15.18.10 Increasing Output Power

In some applications it may be necessary to extend the link range. Adding an external power amplifier is the most effective way of doing this.

The power amplifier should be inserted between the antenna and the balun, and two

T/R switches are needed to disconnect the PA in RX mode.

See Error! Reference source not found..

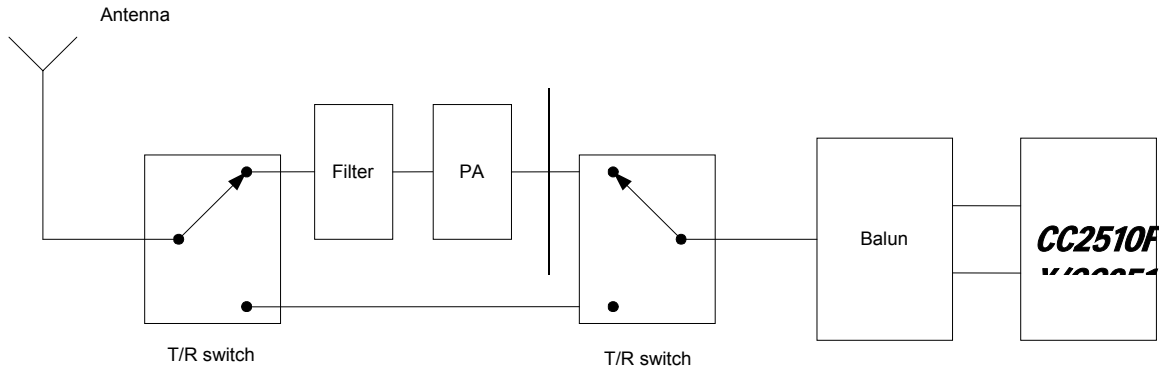

Figure 57. Block diagram of *CC2510Fx/CC2511Fx* usage with external power amplifier

### 15.19 Radio Registers

This section describes all RF registers used for control and status for the radio. The RF registers reside in XDATA memory space in the region 0xDF00-0xDF3D. Table 68 gives an overview of register

addresses while the remaining tables in this section describe each register.

XDATA Address	Register	Description
0xDF00	SYNC1	Sync word, high byte
0xDF01	SYNC0	Sync word, low byte
0xDF02	PKTLEN	Packet length
0xDF03	PKTCTRL1	Packet automation control
0xDF04	PKTCTRL0	Packet automation control
0xDF05	ADDR	Device address
0xDF06	CHANNR	Channel number
0xDF07	FSCTRL1	Frequency synthesizer control
0xDF08	FSCTRL0	Frequency synthesizer control
0xDF09	FREQ2	Frequency control word, high byte
0xDF0A	FREQ1	Frequency control word, middle byte
0xDF0B	FREQ0	Frequency control word, low byte
0xDF0C	MDMCFG4	Modem configuration
0xDF0D	MDMCFG3	Modem configuration
0xDF0E	MDMCFG2	Modem configuration
0xDF0F	MDMCFG1	Modem configuration
0xDF10	MDMCFG0	Modem configuration
0xDF11	DEVIATN	Modem deviation setting
0xDF12	MCSM2	Main Radio Control State Machine configuration
0xDF13	MCSM1	Main Radio Control State Machine configuration
0xDF14	MCSM0	Main Radio Control State Machine configuration
0xDF15	FOCCFG	Frequency Offset Compensation configuration
0xDF16	BSCFG	Bit Synchronization configuration
0xDF17	AGCTRL2	AGC control
0xDF18	AGCTRL1	AGC control
0xDF19	AGCTRL0	AGC control
0xDF1A	FREND1	Front end RX configuration
0xDF1B	FREND0	Front end TX configuration
0xDF1C	FSCAL3	Frequency synthesizer calibration
0xDF1D	FSCAL2	Frequency synthesizer calibration
0xDF1E	FSCAL1	Frequency synthesizer calibration
0xDF1F	FSCAL0	Frequency synthesizer calibration
0xDF20	-	Reserved
0xDF21	-	Reserved
0xDF22	-	Reserved
0xDF23	-	Reserved
0xDF24	-	Reserved
0xDF25	-	Reserved
0xDF27	PA_TABLE7	PA output power setting
0xDF28	PA_TABLE6	PA output power setting
0xDF29	PA_TABLE5	PA output power setting
0xDF2A	PA_TABLE4	PA output power setting
0xDF2B	PA_TABLE3	PA output power setting
0xDF2C	PA_TABLE2	PA output power setting
0xDF2D	PA_TABLE1	PA output power setting
0xDF2E	PA_TABLE0	PA output power setting
0xDF2F	IOCFG2	GDO2 output pin configuration
0xDF30	IOCFG1	GDO1 output pin configuration
0xDF31	IOCFG0	GDO0 output pin configuration

XDATA Address	Register	Description
0xDF36	PARTNUM	Chip Identifier
0xDF37	VERSION	configuration
0xDF38	FREQEST	Frequency Offset Estimate
0xDF39	LQI	Link Quality Indicator
0xDF3A	RSSI	Received Signal Strength Indication
0xDF3B	MARCSTATE	Main Radio Control State
0xDF3C	PKSTATUS	Packet status
0xDF3D	VCO_VC_DAC	PLL calibration current

Table 68: Overview of RF registers

**0xDF2F: IOCFG2 – GDO2 output pin configuration**

Bit	Field Name	Reset	R/W	Description
7	-		R0	Reserved
6	GDO2_INV	0	R/W	Invert output, i.e. select active low / high
5:0	GDO2_CFG[5:0]	0x00	R/W	Debug output on P1_7 pin. See Table 69 for description of internal signals which can be output on this pin for debug purpose

**0xDF30: IOCFG1 – GDO1 output pin configuration**

Bit	Field Name	Reset	R/W	Description
7	GDO_DS	0	R/W	Set high (1) or low (0) output drive strength on the GDO pins.
6	GDO1_INV	0	R/W	Invert output, i.e. select active low / high
5:0	GDO1_CFG[5:0]	0x00	R/W	Debug output on P1_6 pin. See Table 69 for description of internal signals which can be output on this pin for debug purpose

**0xDF31: IOCFG0 – GDO0 output pin configuration**

Bit	Field Name	Reset	R/W	Description
7	TEMP_SENSOR_ENABLE	0	R/W	Enable analog temperature sensor. Write 0 in all other register bits when using temperature sensor.
6	GDO0_INV	0	R/W	Invert output, i.e. select active low / high
5:0	GDO0_CFG[5:0]	0x00	R/W	Debug output on P1_5 pin. See Table 69 for description of internal signals which can be output on this pin for debug purpose

**0xDF00: SYNC1 – Sync word, high byte**

Bit	Field Name	Reset	R/W	Description
7:0	SYNC[15:8]	0xD3	R/W	8 MSB of 16-bit sync word

### 0xDF01: SYNC0 – Sync word, low byte

Bit	Field Name	Reset	R/W	Description
7:0	SYNC[7:0]	0x91	R/W	8 LSB of 16-bit sync word

### 0xDF02: PKTLEN – Packet length

Bit	Field Name	Reset	R/W	Description
7:0	PACKET_LENGTH	0xFF	R/W	Indicates the packet length when fixed length packets are enabled. If variable length packets are used, this value indicates the maximum length packets allowed.

### 0xDF03: PKTCTRL1 – Packet automation control

Bit	Field Name	Reset	R/W	Description										
7:5	PQT[2:0]	000	R/W	Preamble quality estimator threshold. The preamble quality estimator increases an internal counter by one each time a bit is received that is different from the previous bit, and decreases the counter by 4 each time a bit is received that is the same as the last bit. The counter saturates at 0 and 31.  A threshold of 4-PQT for this counter is used to gate sync word detection. When PQT=0 a sync word is always accepted.										
4:3	-	00	R0	Reserved										
2	APPEND_STATUS	1	R/W	When enabled, two status bytes will be appended to the payload of the packet. The status bytes contain RSSI and LQI values, as well as the CRC OK flag.										
1:0	ADR_CHK[1:0]	00	R/W	Controls address check configuration of received packages.  <table border="0"> <tr> <td>Setting</td> <td>Address check configuration</td> </tr> <tr> <td>0 (00)</td> <td>No address check</td> </tr> <tr> <td>1 (01)</td> <td>Address check, no broadcast</td> </tr> <tr> <td>2 (10)</td> <td>Address check, 0 (0x00) broadcast</td> </tr> <tr> <td>3 (11)</td> <td>Address check, 0 (0x00) and 255 (0xFF) broadcast</td> </tr> </table>	Setting	Address check configuration	0 (00)	No address check	1 (01)	Address check, no broadcast	2 (10)	Address check, 0 (0x00) broadcast	3 (11)	Address check, 0 (0x00) and 255 (0xFF) broadcast
Setting	Address check configuration													
0 (00)	No address check													
1 (01)	Address check, no broadcast													
2 (10)	Address check, 0 (0x00) broadcast													
3 (11)	Address check, 0 (0x00) and 255 (0xFF) broadcast													

**0xDF04: PKTCTRL0 – Packet automation control**

Bit	Field Name	Reset	R/W	Description
7	-	0	R0	Reserved
6	WHITE_DATA	1	R/W	Turn data whitening on / off 0: Whitening off 1: Whitening on  Data whitening can only be used when PKTCTRL0 . CC2400_EN = 0 (default).
5:4	PKT_FORMAT[1:0]	00	R/W	Format of RX and TX data  Setting Packet format 0 (00) Normal mode, use FIFOs for RX and TX 1 (01) Serial Synchronous mode, used for backwards compatibility  2 (10) Random TX mode; sends random data using PN9 generator. Used for test. Works as normal mode, setting 0 (00), in RX.  3 (11) Asynchronous transparent mode. Data in on GDO0 and Data out on either of the GDO pins
3	CC2400_EN	0	R/W	Enable CC2400 support. Use same CRC implementation as CC2400.  PKTCTRL0 . WHITE_DATA must be 0 if PKTCTRL0 . CC2400_EN = 1.
2	CRC_EN	1	R/W	1: CRC calculation in TX and CRC check in RX enabled 0: CRC disabled for TX and RX
1:0	LENGTH_CONFIG[1:0]	01	R/W	Configure the packet length  Setting Packet length configuration 0 (00) Fixed length packets, length configured in PKTLEN register 1 (01) Variable length packets, packet length configured by the first byte after sync word 2 (10) Enable infinite length packets 3 (11) Reserved

**0xDF05: ADDR – Device address**

Bit	Field Name	Reset	R/W	Description
7:0	DEVICE_ADDR[7:0]	0x00	R/W	Address used for packet filtration. Optional broadcast addresses are 0 (0x00) and 255 (0xFF).

**0xDF06: CHANNR – Channel number**

Bit	Field Name	Reset	R/W	Description
7:0	CHAN[7:0]	0x00	R/W	The 8-bit unsigned channel number, which is multiplied by the channel spacing setting and added to the base frequency.

**0xDF07: FSCTRL1 – Frequency synthesizer control**

Bit	Field Name	Reset	R/W	Description
7:5	-	000	R0	Not used
4:0	FREQ_IF[4:0]	01111	R/W	<p>The desired IF frequency to employ in RX. Subtracted from FS base frequency in RX and controls the digital complex mixer in the demodulator.</p> $f_{IF} = \frac{f_{XOSC}}{2^{10}} \cdot FREQ\_IF$ <p>The default value gives an IF frequency of 381kHz, assuming a 26.0MHz crystal.</p>

**0xDF08: FSCTRL0 – Frequency synthesizer control**

Bit	Field Name	Reset	R/W	Description
7:0	FREQOFF[7:0]	0x00	R/W	<p>Frequency offset added to the base frequency before being used by the FS. (2-complement).</p> <p>Resolution is <math>F_{XTAL}/2^{14}</math> (1.5kHz-1.7kHz); range is <math>\pm 186</math>kHz to <math>\pm 217</math>kHz, dependent of XTAL frequency.</p> <p>The SAFC strobe command and the automatic AFC mechanism add the current FREQEST value to FREQOFF.</p>

**0xDF09: FREQ2 – Frequency control word, high byte**

Bit	Field Name	Reset	R/W	Description															
7:6	FREQ[23:22]	00	R	FREQ[23:22] is always binary 01 (the FREQ2 register is in the range 85 to 95 with 26MHz-28MHz crystal)															
5:0	FREQ[21:16]	0x1E	R/W	<p>FREQ[23:0] is the base frequency for the frequency synthesizer in increments of <math>F_{XOSC}/2^{16}</math>.</p> $f_{carrier} = \frac{f_{XOSC}}{2^{16}} \cdot FREQ[23:0]$ <p>The default frequency word gives a base frequency of 2464MHz, assuming a 26.0MHz crystal. With the default channel spacing settings, the following FREQ2 values and channel numbers can be used:</p> <table border="1"> <thead> <tr> <th>FREQ2</th> <th>Base frequency</th> <th>Frequency range (CHAN numbers)</th> </tr> </thead> <tbody> <tr> <td>91 (0x5B)</td> <td>2386MHz</td> <td>2400.2MHz-2437MHz (71-255)</td> </tr> <tr> <td>92 (0x5C)</td> <td>2412MHz</td> <td>2412MHz-2463MHz (0-255)</td> </tr> <tr> <td>93 (0x5D)</td> <td>2438MHz</td> <td>2431MHz-2483.4MHz (0-227)</td> </tr> <tr> <td>94 (0x5E)</td> <td>2464MHz</td> <td>2464MHz-2483.4MHz (0-97)</td> </tr> </tbody> </table>	FREQ2	Base frequency	Frequency range (CHAN numbers)	91 (0x5B)	2386MHz	2400.2MHz-2437MHz (71-255)	92 (0x5C)	2412MHz	2412MHz-2463MHz (0-255)	93 (0x5D)	2438MHz	2431MHz-2483.4MHz (0-227)	94 (0x5E)	2464MHz	2464MHz-2483.4MHz (0-97)
FREQ2	Base frequency	Frequency range (CHAN numbers)																	
91 (0x5B)	2386MHz	2400.2MHz-2437MHz (71-255)																	
92 (0x5C)	2412MHz	2412MHz-2463MHz (0-255)																	
93 (0x5D)	2438MHz	2431MHz-2483.4MHz (0-227)																	
94 (0x5E)	2464MHz	2464MHz-2483.4MHz (0-97)																	

**0xDF0A: FREQ1 – Frequency control word, middle byte**

Bit	Field Name	Reset	R/W	Description
7:0	FREQ[15:8]	0xC4	R/W	Ref. FREQ2 register



**0xDF0B: FREQ0 – Frequency control word, low byte**

Bit	Field Name	Reset	R/W	Description
7:0	FREQ[7:0]	0xEC	R/W	Ref. FREQ2 register

**0xDF0C: MDMCFG4 – Modem configuration**

Bit	Field Name	Reset	R/W	Description
7:6	CHANBW_E[1:0]	10	R/W	
5:4	CHANBW_M[1:0]	00	R/W	<p>Sets the decimation ratio for the delta-sigma ADC input stream and thus the channel bandwidth.</p> $BW_{channel} = \frac{f_{XOSC}}{8 \cdot (4 + CHANBW\_M) \cdot 2^{CHANBW\_E}}$ <p>The default values give 203kHz channel filter bandwidth, assuming a 26.0MHz crystal.</p>
3:0	DRATE_E[3:0]	1100	R/W	The exponent of the user specified symbol rate

**0xDF0D: MDMCFG3 – Modem configuration**

Bit	Field Name	Reset	R/W	Description
7:0	DRATE_M[7:0]	0x22	R/W	<p>The mantissa of the user specified symbol rate. The symbol rate is configured using an unsigned, floating-point number with 9-bit mantissa and 4-bit exponent. The 9<sup>th</sup> bit is a hidden '1'. The resulting data rate is:</p> $R_{DATA} = \frac{(256 + DRATE\_M) \cdot 2^{DRATE\_E}}{2^{28}} \cdot f_{XOSC}$ <p>The default values give a data rate of 115.051kbps (closest setting to 115.2kbps), assuming a 26.0MHz crystal.</p>

0xDF0E: MDMCFG2 – Modem configuration

Bit	Field Name	Reset	R/W	Description
7	DEM_DCFILT_OFF	0	R/W	Disable digital DC blocking filter before demodulator. 0 = Enable (better sensitivity for data rates $\leq$ 250 kbps) 1 = Disable (reduced power consumption) The recommended IF frequency changes when the DC blocking is disabled.
6:4	MOD_FORMAT[2:0]	000	R/W	The modulation format of the radio signal Setting      Modulation format 0 (000)      2-FSK 1 (001)      GFSK 2 (010)      - 3 (011)      OOK 4 (100)      - 5 (101)      - 6 (110)      - 7 (111)      MSK
3	MANCHESTER_EN	0	R/W	Enables Manchester encoding/decoding. 0 = Disable 1 = Enable
2:0	SYNC_MODE[2:0]	010	R/W	Combined sync-word qualifier mode. The values 0 (000) and 4 (100) disables sync word transmission in TX and sync word detection in RX. The values 1 (001), 2 (001), 5 (101) and 6 (110) enables 16-bit sync word transmission in TX and 16-bits sync word detection in RX. Only 15 of 16 bits need to match in RX when using setting 1 (001) or 5 (101). The values 3 (011) and 7 (111) enables repeated sync word transmission in RX and 32-bits sync word detection in RX (only 30 of 32 bits need to match). Setting      Sync-word qualifier mode 0 (000)      No preamble/sync 1 (001)      15/16 sync word bits detected 2 (010)      16/16 sync word bits detected 3 (011)      30/32 sync word bits detected 4 (100)      No preamble/sync, carrier-sense above threshold 5 (101)      15/16 + carrier-sense above threshold 6 (110)      16/16 + carrier-sense above threshold 7 (111)      30/32 + carrier-sense above threshold

0xDF0F: MDMCFG1 – Modem configuration

Bit	Field Name	Reset	R/W	Description																		
7	FEC_EN	0	R/W	Enable Forward Error Correction (FEC) with interleaving for packet payload 0 = Disable 1 = Enable																		
6:4	NUM_PREAMBLE[2:0]	010	R/W	Sets the minimum number of preamble bytes to be transmitted  <table style="margin-left: 20px;"> <thead> <tr> <th>Setting</th> <th>Number of preamble bytes</th> </tr> </thead> <tbody> <tr><td>0 (000)</td><td>2</td></tr> <tr><td>1 (001)</td><td>3</td></tr> <tr><td>2 (010)</td><td>4</td></tr> <tr><td>3 (011)</td><td>6</td></tr> <tr><td>4 (100)</td><td>8</td></tr> <tr><td>5 (101)</td><td>12</td></tr> <tr><td>6 (110)</td><td>16</td></tr> <tr><td>7 (111)</td><td>24</td></tr> </tbody> </table>	Setting	Number of preamble bytes	0 (000)	2	1 (001)	3	2 (010)	4	3 (011)	6	4 (100)	8	5 (101)	12	6 (110)	16	7 (111)	24
Setting	Number of preamble bytes																					
0 (000)	2																					
1 (001)	3																					
2 (010)	4																					
3 (011)	6																					
4 (100)	8																					
5 (101)	12																					
6 (110)	16																					
7 (111)	24																					
3:2	-	0	R0	Reserved																		
1:0	CHANSPC_E[1:0]	10	R/W	2 bit exponent of channel spacing																		

0xDF10: MDMCFG0 – Modem configuration

Bit	Field Name	Reset	R/W	Description
7:0	CHANSPC_M[7:0]	0xF8	R/W	8-bit mantissa of channel spacing (initial 1 assumed). The channel spacing is multiplied by the channel number CHAN and added to the base frequency. It is unsigned and has the format:  $\Delta f_{CHANNEL} = \frac{f_{XOSC}}{2^{18}} \cdot (256 + CHANSPC\_M) \cdot 2^{CHANSPC\_E} \cdot CHAN$ <p>The default values give 199.951kHz channel spacing (the closest setting to 200kHz), assuming 26.0MHz crystal frequency.</p>

**0xDF11: DEVIATN – Modem deviation setting**

Bit	Field Name	Reset	R/W	Description
7	-	0	R0	Reserved
6:4	DEVIATION_E[2:0]	100	R/W	Deviation exponent
3	-	0	R0	Reserved
2:0	DEVIATION_M[2:0]	111	R/W	<p>When MSK modulation is enabled: Sets fraction of symbol period used for phase change.</p> <p>When FSK modulation is enabled: Deviation mantissa, interpreted as a 4-bit value with MSB implicit 1. The resulting FSK deviation is given by:</p> $f_{dev} = \frac{f_{xosc}}{2^{17}} \cdot (8 + DEVIATION\_M) \cdot 2^{DEVIATION\_E}$ <p>The default values give <math>\pm 47.607</math>kHz deviation, assuming 26.0MHz crystal frequency.</p>

0xDF12: MCSM2 – Main Radio Control State Machine configuration

Bit	Field Name	Reset	R/W	Description																																																																								
7:5	Reserved		R0	Reserved																																																																								
4	RX_TIME_RSSI	0	R/W	Direct RX termination based on RSSI measurement (carrier sense). For OOK modulation, RX times out if there is no carrier sense in the first 8 symbol periods.																																																																								
3	RX_TIME_QUAL	0	R/W	When the RX_TIME timer expires the chip stays in RX mode if sync word is found when RX_TIME_QUAL=0, or either sync word is found or PQT is set when RX_TIME_QUAL=1.																																																																								
2:0	RX_TIME[2:0]	7 (111)	R/W	Timeout for sync word search in RX. The timeout is relative to the programmed EVENT0 timeout, which means that the duty cycle can be set in wake-on-radio (WOR) mode.																																																																								
<p>The RX timeout in <math>\mu</math>s is given by <math>EVENT0 \cdot C(RX\_TIME, WOR\_RES)</math>, where C is given by the table below (XOSC = 26 MHz):</p> <table border="1"> <thead> <tr> <th>RX_TIME[2:0]</th> <th>WOR_RES = 0</th> <th>WOR_RES = 1</th> <th>WOR_RES = 2</th> <th>WOR_RES = 3</th> </tr> </thead> <tbody> <tr><td>0 (000)</td><td>3.6058</td><td>18.0288</td><td>32.4519</td><td>46.8750</td></tr> <tr><td>1 (001)</td><td>1.8029</td><td>9.0144</td><td>16.2260</td><td>23.4375</td></tr> <tr><td>2 (010)</td><td>0.9014</td><td>4.5072</td><td>8.1130</td><td>11.7188</td></tr> <tr><td>3 (011)</td><td>0.4507</td><td>2.2536</td><td>4.0565</td><td>5.8594</td></tr> <tr><td>4 (100)</td><td>0.2254</td><td>1.1268</td><td>2.0282</td><td>2.9297</td></tr> <tr><td>5 (101)</td><td>0.1127</td><td>0.5634</td><td>1.0141</td><td>1.4648</td></tr> <tr><td>6 (110)</td><td>0.0563</td><td>0.2817</td><td>0.5071</td><td>0.7324</td></tr> <tr><td>7 (111)</td><td colspan="4">Until end of packet</td></tr> </tbody> </table> <p>As an example, EVENT0 = 34666, WOR_RES = 0 and RX_TIME = 6 corresponds to 1.96 ms RX timeout, 1 s polling interval and 0.195% duty cycle. Note that WOR_RES should be 0 or 1 when using WOR.</p> <p>The duty cycle is approximated by:</p> <table border="1"> <thead> <tr> <th>RX_TIME[2:0]</th> <th>WOR_RES = 0</th> <th>WOR_RES = 1</th> </tr> </thead> <tbody> <tr><td>0 (000)</td><td>12.50%</td><td>1.95%</td></tr> <tr><td>1 (001)</td><td>6.250%</td><td>9765ppm</td></tr> <tr><td>2 (010)</td><td>3.125%</td><td>4883ppm</td></tr> <tr><td>3 (011)</td><td>1.563%</td><td>2441ppm</td></tr> <tr><td>4 (100)</td><td>0.781%</td><td>NA</td></tr> <tr><td>5 (101)</td><td>0.391%</td><td>NA</td></tr> <tr><td>6 (110)</td><td>0.195%</td><td>NA</td></tr> <tr><td>7 (111)</td><td colspan="2">Until end of packet</td></tr> </tbody> </table> <p>Note that the RC oscillator must be enabled in order to use setting 0-6, because the timeout counts RC oscillator periods. WOR mode does not need to be enabled. The timeout counter resolution is limited: With RX_TIME=0, the timeout count is given by the 13 MSBs of EVENT0, decreasing to the 7 MSBs of EVENT0 with RX_TIME=6.</p>					RX_TIME[2:0]	WOR_RES = 0	WOR_RES = 1	WOR_RES = 2	WOR_RES = 3	0 (000)	3.6058	18.0288	32.4519	46.8750	1 (001)	1.8029	9.0144	16.2260	23.4375	2 (010)	0.9014	4.5072	8.1130	11.7188	3 (011)	0.4507	2.2536	4.0565	5.8594	4 (100)	0.2254	1.1268	2.0282	2.9297	5 (101)	0.1127	0.5634	1.0141	1.4648	6 (110)	0.0563	0.2817	0.5071	0.7324	7 (111)	Until end of packet				RX_TIME[2:0]	WOR_RES = 0	WOR_RES = 1	0 (000)	12.50%	1.95%	1 (001)	6.250%	9765ppm	2 (010)	3.125%	4883ppm	3 (011)	1.563%	2441ppm	4 (100)	0.781%	NA	5 (101)	0.391%	NA	6 (110)	0.195%	NA	7 (111)	Until end of packet	
RX_TIME[2:0]	WOR_RES = 0	WOR_RES = 1	WOR_RES = 2	WOR_RES = 3																																																																								
0 (000)	3.6058	18.0288	32.4519	46.8750																																																																								
1 (001)	1.8029	9.0144	16.2260	23.4375																																																																								
2 (010)	0.9014	4.5072	8.1130	11.7188																																																																								
3 (011)	0.4507	2.2536	4.0565	5.8594																																																																								
4 (100)	0.2254	1.1268	2.0282	2.9297																																																																								
5 (101)	0.1127	0.5634	1.0141	1.4648																																																																								
6 (110)	0.0563	0.2817	0.5071	0.7324																																																																								
7 (111)	Until end of packet																																																																											
RX_TIME[2:0]	WOR_RES = 0	WOR_RES = 1																																																																										
0 (000)	12.50%	1.95%																																																																										
1 (001)	6.250%	9765ppm																																																																										
2 (010)	3.125%	4883ppm																																																																										
3 (011)	1.563%	2441ppm																																																																										
4 (100)	0.781%	NA																																																																										
5 (101)	0.391%	NA																																																																										
6 (110)	0.195%	NA																																																																										
7 (111)	Until end of packet																																																																											

**0xDF13: MCSM1 – Main Radio Control State Machine configuration**

Bit	Field Name	Reset	R/W	Description
7:6	-	00	R0	Reserved
5:4	CCA_MODE[1:0]	11	R/W	Selects CCA_MODE; Reflected in CCA signal Setting    Clear channel indication 0 (00)    Always 1 (01)    If RSSI below threshold 2 (10)    Unless currently receiving a packet 3 (11)    If RSSI below threshold unless currently receiving a packet
3:2	RXOFF_MODE[1:0]	00	R/W	Select what should happen when a packet has been received Setting    Next state after finishing packet reception 0 (00)    IDLE 1 (01)    FSTXON 2 (10)    TX 3 (11)    Stay in RX
1:0	TXOFF_MODE[1:0]	00	R/W	Select what should happen when a packet has been sent (TX) Setting    Next state after finishing packet transmission 0 (00)    IDLE 1 (01)    FSTXON 2 (10)    Stay in TX (start sending preamble) 3 (11)    RX

**0xDF14: MCSM0 – Main Radio Control State Machine configuration**

Bit	Field Name	Reset	R/W	Description
7:6	-	00	R0	Reserved
5:4	FS_AUTOCAL[1:0]	00	R/W	Automatically calibrate when going to RX or TX, or back to IDLE Setting    When to perform automatic calibration 0 (00)    Never (manually calibrate using SCAL strobe) 1 (01)    When going from IDLE to RX or TX (or FSTXON) 2 (10)    When going from RX or TX back to IDLE 3 (11)    Every 4 <sup>th</sup> time when going from RX or TX to IDLE In some automatic wake-on-radio (WOR) applications, using setting 3 (11) can significantly reduce current consumption.
3:0	-	0100	R	Reserved

0xDF15: FOCCFG – Frequency Offset Compensation configuration

Bit	Field Name	Reset	R/W	Description										
7:6	Reserved		R0											
5	FOC_BS_CS_GATE	1	R/W	If set, the demodulator freezes the frequency offset compensation and clock recovery feedback loops until the CARRIER_SENSE signal goes high.										
4:3	FOC_PRE_K[1:0]	2 (10)	R/W	<p>The frequency compensation loop gain to be used before a sync word is detected.</p> <table border="1"> <thead> <tr> <th>Setting</th> <th>Freq. compensation loop gain before sync word</th> </tr> </thead> <tbody> <tr> <td>0 (00)</td> <td><math>K</math></td> </tr> <tr> <td>1 (01)</td> <td><math>2K</math></td> </tr> <tr> <td>2 (10)</td> <td><math>3K</math></td> </tr> <tr> <td>3 (11)</td> <td><math>4K</math></td> </tr> </tbody> </table>	Setting	Freq. compensation loop gain before sync word	0 (00)	$K$	1 (01)	$2K$	2 (10)	$3K$	3 (11)	$4K$
Setting	Freq. compensation loop gain before sync word													
0 (00)	$K$													
1 (01)	$2K$													
2 (10)	$3K$													
3 (11)	$4K$													
2	FOC_POST_K	1	R/W	<p>The frequency compensation loop gain to be used after a sync word is detected.</p> <table border="1"> <thead> <tr> <th>Setting</th> <th>Freq. compensation loop gain after sync word</th> </tr> </thead> <tbody> <tr> <td>0</td> <td>Same as FOC_PRE_K</td> </tr> <tr> <td>1</td> <td><math>K/2</math></td> </tr> </tbody> </table>	Setting	Freq. compensation loop gain after sync word	0	Same as FOC_PRE_K	1	$K/2$				
Setting	Freq. compensation loop gain after sync word													
0	Same as FOC_PRE_K													
1	$K/2$													
1:0	FOC_LIMIT[1:0]	2 (10)	R/W	<p>The saturation point for the frequency offset compensation algorithm:</p> <table border="1"> <thead> <tr> <th>Setting</th> <th>Saturation point (max compensated offset)</th> </tr> </thead> <tbody> <tr> <td>0 (00)</td> <td><math>\pm 0</math> (no frequency offset compensation)</td> </tr> <tr> <td>1 (01)</td> <td><math>\pm BW_{CHAN}/8</math></td> </tr> <tr> <td>2 (10)</td> <td><math>\pm BW_{CHAN}/4</math></td> </tr> <tr> <td>3 (11)</td> <td><math>\pm BW_{CHAN}/2</math></td> </tr> </tbody> </table> <p>Frequency offset compensation is not supported for OOK; Always use FOC_LIMIT=0 with this modulation format.</p>	Setting	Saturation point (max compensated offset)	0 (00)	$\pm 0$ (no frequency offset compensation)	1 (01)	$\pm BW_{CHAN}/8$	2 (10)	$\pm BW_{CHAN}/4$	3 (11)	$\pm BW_{CHAN}/2$
Setting	Saturation point (max compensated offset)													
0 (00)	$\pm 0$ (no frequency offset compensation)													
1 (01)	$\pm BW_{CHAN}/8$													
2 (10)	$\pm BW_{CHAN}/4$													
3 (11)	$\pm BW_{CHAN}/2$													

0xDF16: BSCFG – Bit Synchronization configuration

Bit	Field Name	Reset	R/W	Description										
7:6	BS_PRE_KI[1:0]	1 (01)	R/W	<p>The clock recovery feedback loop integral gain to be used before a sync word is detected (used to correct offsets in data rate):</p> <table border="1"> <thead> <tr> <th>Setting</th> <th>Clock recovery loop integral gain before sync word</th> </tr> </thead> <tbody> <tr> <td>0 (00)</td> <td><math>K_I</math></td> </tr> <tr> <td>1 (01)</td> <td><math>2K_I</math></td> </tr> <tr> <td>2 (10)</td> <td><math>3K_I</math></td> </tr> <tr> <td>3 (11)</td> <td><math>4K_I</math></td> </tr> </tbody> </table>	Setting	Clock recovery loop integral gain before sync word	0 (00)	$K_I$	1 (01)	$2K_I$	2 (10)	$3K_I$	3 (11)	$4K_I$
Setting	Clock recovery loop integral gain before sync word													
0 (00)	$K_I$													
1 (01)	$2K_I$													
2 (10)	$3K_I$													
3 (11)	$4K_I$													
5:4	BS_PRE_KP[1:0]	2 (10)	R/W	<p>The clock recovery feedback loop proportional gain to be used before a sync word is detected.</p> <table border="1"> <thead> <tr> <th>Setting</th> <th>Clock recovery loop proportional gain before sync word</th> </tr> </thead> <tbody> <tr> <td>0 (00)</td> <td><math>K_P</math></td> </tr> <tr> <td>1 (01)</td> <td><math>2K_P</math></td> </tr> <tr> <td>2 (10)</td> <td><math>3K_P</math></td> </tr> <tr> <td>3 (11)</td> <td><math>4K_P</math></td> </tr> </tbody> </table>	Setting	Clock recovery loop proportional gain before sync word	0 (00)	$K_P$	1 (01)	$2K_P$	2 (10)	$3K_P$	3 (11)	$4K_P$
Setting	Clock recovery loop proportional gain before sync word													
0 (00)	$K_P$													
1 (01)	$2K_P$													
2 (10)	$3K_P$													
3 (11)	$4K_P$													
3	BS_POST_KI	1	R/W	<p>The clock recovery feedback loop integral gain to be used after a sync word is detected.</p> <table border="1"> <thead> <tr> <th>Setting</th> <th>Clock recovery loop integral gain after sync word</th> </tr> </thead> <tbody> <tr> <td>0</td> <td>Same as BS_PRE_KI</td> </tr> <tr> <td>1</td> <td><math>K_I/2</math></td> </tr> </tbody> </table>	Setting	Clock recovery loop integral gain after sync word	0	Same as BS_PRE_KI	1	$K_I/2$				
Setting	Clock recovery loop integral gain after sync word													
0	Same as BS_PRE_KI													
1	$K_I/2$													
2	BS_POST_KP	1	R/W	<p>The clock recovery feedback loop proportional gain to be used after a sync word is detected.</p> <table border="1"> <thead> <tr> <th>Setting</th> <th>Clock recovery loop proportional gain after sync word</th> </tr> </thead> <tbody> <tr> <td>0</td> <td>Same as BS_PRE_KP</td> </tr> <tr> <td>1</td> <td><math>K_P</math></td> </tr> </tbody> </table>	Setting	Clock recovery loop proportional gain after sync word	0	Same as BS_PRE_KP	1	$K_P$				
Setting	Clock recovery loop proportional gain after sync word													
0	Same as BS_PRE_KP													
1	$K_P$													
1:0	BS_LIMIT[1:0]	0 (00)	R/W	<p>The saturation point for the data rate offset compensation algorithm:</p> <table border="1"> <thead> <tr> <th>Setting</th> <th>Data rate offset saturation (max data rate difference)</th> </tr> </thead> <tbody> <tr> <td>0 (00)</td> <td><math>\pm 0</math> (No data rate offset compensation performed)</td> </tr> <tr> <td>1 (01)</td> <td><math>\pm 3.125\%</math> data rate offset</td> </tr> <tr> <td>2 (10)</td> <td><math>\pm 6.25\%</math> data rate offset</td> </tr> <tr> <td>3 (11)</td> <td><math>\pm 12.5\%</math> data rate offset</td> </tr> </tbody> </table>	Setting	Data rate offset saturation (max data rate difference)	0 (00)	$\pm 0$ (No data rate offset compensation performed)	1 (01)	$\pm 3.125\%$ data rate offset	2 (10)	$\pm 6.25\%$ data rate offset	3 (11)	$\pm 12.5\%$ data rate offset
Setting	Data rate offset saturation (max data rate difference)													
0 (00)	$\pm 0$ (No data rate offset compensation performed)													
1 (01)	$\pm 3.125\%$ data rate offset													
2 (10)	$\pm 6.25\%$ data rate offset													
3 (11)	$\pm 12.5\%$ data rate offset													



0xDF17: AGCTRL2 – AGC control

Bit	Field Name	Reset	R/W	Description
7: 6	MAX_DVGA_GAIN[1:0]	0 (00)	R/W	Reduces the maximum allowable DVGA gain.  Setting    Allowable DVGA settings 0 (00)    All gain settings can be used 1 (01)    The highest gain setting can not be used 2 (10)    The 2 highest gain settings can not be used 3 (11)    The 3 highest gain settings can not be used
5: 3	MAX_LNA_GAIN[2:0]	0 (000)	R/W	Sets the maximum allowable LNA + LNA 2 gain relative to the maximum possible gain.  Setting    Maximum allowable LNA + LNA 2 gain 0 (000)    Maximum possible LNA + LNA 2 gain 1 (001)    Approx. 2.6 dB below maximum possible gain 2 (010)    Approx. 6.1 dB below maximum possible gain 3 (011)    Approx. 7.4 dB below maximum possible gain 4 (100)    Approx. 9.2 dB below maximum possible gain 5 (101)    Approx. 11.5 dB below maximum possible gain 6 (110)    Approx. 14.6 dB below maximum possible gain 7 (111)    Approx. 17.1 dB below maximum possible gain
2: 0	MAGN_TARGET[2:0]	3 (011)	R/W	These bits set the target value for the averaged amplitude from the digital channel filter (1 LSB = 0 dB).  Setting    Target amplitude from channel filter 0 (000)    24 dB 1 (001)    27 dB 2 (010)    30 dB 3 (011)    33 dB 4 (100)    36 dB 5 (101)    38 dB 6 (110)    40 dB 7 (111)    42 dB

**0xDF18: AGCTRL1 – AGC control**

Bit	Field Name	Reset	R/W	Description																		
7	Reserved		R0																			
6	AGC_LNA_PRIORITY	1	R/W	Selects between two different strategies for LNA and LNA 2 gain adjustment. When 1, the LNA gain is decreased first. When 0, the LNA 2 gain is decreased to minimum before decreasing LNA gain.																		
5:4	CARRIER_SENSE_REL_THR[1:0]	0 (00)	R/W	<p>Sets the relative change threshold for asserting carrier sense</p> <table border="0"> <tr> <td>Setting</td> <td>Carrier sense relative threshold</td> </tr> <tr> <td>0 (00)</td> <td>Relative carrier sense threshold disabled</td> </tr> <tr> <td>1 (01)</td> <td>6 dB increase in RSSI value</td> </tr> <tr> <td>2 (10)</td> <td>10 dB increase in RSSI value</td> </tr> <tr> <td>3 (11)</td> <td>14 dB increase in RSSI value</td> </tr> </table>	Setting	Carrier sense relative threshold	0 (00)	Relative carrier sense threshold disabled	1 (01)	6 dB increase in RSSI value	2 (10)	10 dB increase in RSSI value	3 (11)	14 dB increase in RSSI value								
Setting	Carrier sense relative threshold																					
0 (00)	Relative carrier sense threshold disabled																					
1 (01)	6 dB increase in RSSI value																					
2 (10)	10 dB increase in RSSI value																					
3 (11)	14 dB increase in RSSI value																					
3:0	CARRIER_SENSE_ABS_THR[3:0]	0 (0000)	R/W	<p>Sets the absolute RSSI threshold for asserting carrier sense. The 2-complement signed threshold is programmed in steps of 1 dB and is relative to the MAGN_TARGET setting.</p> <table border="0"> <tr> <td>Setting</td> <td>Carrier sense absolute threshold (Equal to channel filter amplitude when AGC has not decreased gain)</td> </tr> <tr> <td>-8 (1000)</td> <td>Absolute carrier sense threshold disabled</td> </tr> <tr> <td>-7 (1001)</td> <td>7 dB below MAGN_TARGET setting</td> </tr> <tr> <td>...</td> <td>...</td> </tr> <tr> <td>-1 (1111)</td> <td>1 dB below MAGN_TARGET setting</td> </tr> <tr> <td>0 (0000)</td> <td>At MAGN_TARGET setting</td> </tr> <tr> <td>1 (0001)</td> <td>1 dB above MAGN_TARGET setting</td> </tr> <tr> <td>...</td> <td>...</td> </tr> <tr> <td>7 (0111)</td> <td>7 dB above MAGN_TARGET setting</td> </tr> </table>	Setting	Carrier sense absolute threshold (Equal to channel filter amplitude when AGC has not decreased gain)	-8 (1000)	Absolute carrier sense threshold disabled	-7 (1001)	7 dB below MAGN_TARGET setting	...	...	-1 (1111)	1 dB below MAGN_TARGET setting	0 (0000)	At MAGN_TARGET setting	1 (0001)	1 dB above MAGN_TARGET setting	...	...	7 (0111)	7 dB above MAGN_TARGET setting
Setting	Carrier sense absolute threshold (Equal to channel filter amplitude when AGC has not decreased gain)																					
-8 (1000)	Absolute carrier sense threshold disabled																					
-7 (1001)	7 dB below MAGN_TARGET setting																					
...	...																					
-1 (1111)	1 dB below MAGN_TARGET setting																					
0 (0000)	At MAGN_TARGET setting																					
1 (0001)	1 dB above MAGN_TARGET setting																					
...	...																					
7 (0111)	7 dB above MAGN_TARGET setting																					

0xDF19: AGCTRL0 – AGC control

Bit	Field Name	Reset	R/W	Description										
7:6	HYST_LEVEL[1:0]	2 (10)	R/W	<p>Sets the level of hysteresis on the magnitude deviation (internal AGC signal that determine gain changes).</p> <table border="1"> <thead> <tr> <th>Setting</th> <th>Description</th> </tr> </thead> <tbody> <tr> <td>0 (00)</td> <td>No hysteresis, small symmetric dead zone, high gain</td> </tr> <tr> <td>1 (01)</td> <td>Low hysteresis, small asymmetric dead zone, medium gain</td> </tr> <tr> <td>2 (10)</td> <td>Medium hysteresis, medium asymmetric dead zone, medium gain</td> </tr> <tr> <td>3 (11)</td> <td>Large hysteresis, large asymmetric dead zone, low gain</td> </tr> </tbody> </table>	Setting	Description	0 (00)	No hysteresis, small symmetric dead zone, high gain	1 (01)	Low hysteresis, small asymmetric dead zone, medium gain	2 (10)	Medium hysteresis, medium asymmetric dead zone, medium gain	3 (11)	Large hysteresis, large asymmetric dead zone, low gain
Setting	Description													
0 (00)	No hysteresis, small symmetric dead zone, high gain													
1 (01)	Low hysteresis, small asymmetric dead zone, medium gain													
2 (10)	Medium hysteresis, medium asymmetric dead zone, medium gain													
3 (11)	Large hysteresis, large asymmetric dead zone, low gain													
5:4	WAIT_TIME[1:0]	1 (01)	R/W	<p>Sets the number of channel filter samples from a gain adjustment has been made until the AGC algorithm starts accumulating new samples.</p> <table border="1"> <thead> <tr> <th>Setting</th> <th>Channel filter samples</th> </tr> </thead> <tbody> <tr> <td>0 (00)</td> <td>8</td> </tr> <tr> <td>1 (01)</td> <td>16</td> </tr> <tr> <td>2 (10)</td> <td>24</td> </tr> <tr> <td>3 (11)</td> <td>32</td> </tr> </tbody> </table>	Setting	Channel filter samples	0 (00)	8	1 (01)	16	2 (10)	24	3 (11)	32
Setting	Channel filter samples													
0 (00)	8													
1 (01)	16													
2 (10)	24													
3 (11)	32													
3:2	AGC_FREEZE[1:0]	0 (00)	R/W	<p>Controls when the AGC gain should be frozen.</p> <table border="1"> <thead> <tr> <th>Setting</th> <th>Function</th> </tr> </thead> <tbody> <tr> <td>0 (00)</td> <td>Normal operation. Always adjust gain when required.</td> </tr> <tr> <td>1 (01)</td> <td>The gain setting is frozen when a sync word has been found.</td> </tr> <tr> <td>2 (10)</td> <td>Manually freeze the analog gain setting and continue to adjust the digital gain.</td> </tr> <tr> <td>3 (11)</td> <td>Manually freezes both the analog and the digital gain settings. Used for manually overriding the gain.</td> </tr> </tbody> </table>	Setting	Function	0 (00)	Normal operation. Always adjust gain when required.	1 (01)	The gain setting is frozen when a sync word has been found.	2 (10)	Manually freeze the analog gain setting and continue to adjust the digital gain.	3 (11)	Manually freezes both the analog and the digital gain settings. Used for manually overriding the gain.
Setting	Function													
0 (00)	Normal operation. Always adjust gain when required.													
1 (01)	The gain setting is frozen when a sync word has been found.													
2 (10)	Manually freeze the analog gain setting and continue to adjust the digital gain.													
3 (11)	Manually freezes both the analog and the digital gain settings. Used for manually overriding the gain.													
1:0	FILTER_LENGTH[1:0]	1 (01)	R/W	<p>Sets the averaging length for the amplitude from the channel filter.</p> <table border="1"> <thead> <tr> <th>Setting</th> <th>Channel filter samples</th> </tr> </thead> <tbody> <tr> <td>0 (00)</td> <td>8</td> </tr> <tr> <td>1 (01)</td> <td>16</td> </tr> <tr> <td>2 (10)</td> <td>32</td> </tr> <tr> <td>3 (11)</td> <td>64</td> </tr> </tbody> </table>	Setting	Channel filter samples	0 (00)	8	1 (01)	16	2 (10)	32	3 (11)	64
Setting	Channel filter samples													
0 (00)	8													
1 (01)	16													
2 (10)	32													
3 (11)	64													

0xDF1A: FRENDD1 – Front end RX configuration

Bit	Field Name	Reset	R/W	Description
7:6	LNA_CURRENT[1:0]	1 (01)	R/W	Adjusts front-end LNA PTAT current output
5:4	LNA2MIX_CURRENT[1:0]	1 (01)	R/W	Adjusts front-end PTAT outputs
3:2	LODIV_BUF_CURRENT_RX[1:0]	1 (01)	R/W	Adjusts current in RX LO buffer (LO input to mixer)
1:0	MIX_CURRENT[1:0]	2 (10)	R/W	Adjusts current in mixer

**0xDF1B: FRENDO – Front end TX configuration**

Bit	Field Name	Reset	R/W	Description
7:6	-	00	R0	Reserved
5:4	LODIV_BUF_CURRENT_TX[1:0]	01	R/W	Adjusts current TX LO buffer (input to PA). The value to use in this field is given by the SmartRF® Studio software.
3	-	0	R0	Reserved
2:0	PA_POWER[2:0]	000	R/W	Selects PA power setting. This value is an index to the PATABLE, which can be programmed with up to 8 different PA settings. The PATABLE settings from index '0' to the PA_POWER value are used for power ramp-up/ramp-down at the start/end of transmission in all TX modulation formats.

**0xDF1C: FSCAL3 – Frequency synthesizer calibration**

Bit	Field Name	Reset	R/W	Description
7:6	FSCAL3[7:6]	2 (10)	R/W	Frequency synthesizer calibration configuration. The value to write in this register before calibration is given by the SmartRF® Studio software.
5:4	CHP_CURR_CAL_EN[1:0]	2 (10)	R/W	Disable charge pump calibration stage when 0
3:0	FSCAL3[3:0]	9 (1001)	R/W	Frequency synthesizer calibration result register. Fast frequency hopping without calibration for each hop can be done by calibrating upfront for each frequency and saving the resulting FSCAL3, FSCAL2 and FSCAL1 register values. Between each frequency hop, calibration can be replaced by writing the FSCAL3, FSCAL2 and FSCAL1 register values corresponding to the next RF frequency.

**0xDF1D: FSCAL2 – Frequency synthesizer calibration**

Bit	Field Name	Reset	R/W	Description
7:6	-	00	R0	Reserved
5:0	FSCAL2[5:0]	0x0A	R/W	Frequency synthesizer calibration result register. Fast frequency hopping without calibration for each hop can be done by calibrating upfront for each frequency and saving the resulting FSCAL3, FSCAL2 and FSCAL1 register values. Between each frequency hop, calibration can be replaced by writing the FSCAL3, FSCAL2 and FSCAL1 register values corresponding to the next RF frequency.

**0xDF1E: FSCAL1 – Frequency synthesizer calibration**

Bit	Field Name	Reset	R/W	Description
7:6	-	00	R0	Reserved
5:0	FSCAL1[5:0]	0x02	R/W	Frequency synthesizer calibration result register. Fast frequency hopping without calibration for each hop can be done by calibrating upfront for each frequency and saving the resulting FSCAL3, FSCAL2 and FSCAL1 register values. Between each frequency hop, calibration can be replaced by writing the FSCAL3, FSCAL2 and FSCAL1 register values corresponding to the next RF frequency.

**0xDF1F: FSCAL0 – Frequency synthesizer calibration**

Bit	Field Name	Reset	R/W	Description
7	-	0	R0	Reserved
4:0	FSCAL0[6:0]	0x0D	R/W	Frequency synthesizer calibration control. The value to use in this register is given by the SmartRF® Studio software.

**0xDF27: PA\_TABLE7 – PA power setting 7**

Bit	Field Name	Reset	R/W	Description
7:0	PA_TABLE7[7:0]	0x00	R/W	Power amplifier output power setting 7 Currently used PA output power is selected by FREND0.PA_POWER[2:0]

**0xDF28: PA\_TABLE6 – PA power setting 6**

Bit	Field Name	Reset	R/W	Description
7:0	PA_TABLE6[7:0]	0x00	R/W	Power amplifier output power setting 6 Currently used PA output power is selected by FREND0.PA_POWER[2:0]

**0xDF29: PA\_TABLE5 – PA power setting 5**

Bit	Field Name	Reset	R/W	Description
7:0	PA_TABLE5[7:0]	0x00	R/W	Power amplifier output power setting 5 Currently used PA output power is selected by FREND0.PA_POWER[2:0]

**0xDF2A: PA\_TABLE4 – PA power setting 4**

Bit	Field Name	Reset	R/W	Description
7:0	PA_TABLE4[7:0]	0x00	R/W	Power amplifier output power setting 4 Currently used PA output power is selected by FREND0.PA_POWER[2:0]

**0xDF2B: PA\_TABLE3 – PA power setting 3**

Bit	Field Name	Reset	R/W	Description
7:0	PA_TABLE3[7:0]	0x00	R/W	Power amplifier output power setting 3 Currently used PA output power is selected by FREND0.PA_POWER[2:0]

**0xDF2C: PA\_TABLE2 – PA power setting 2**

Bit	Field Name	Reset	R/W	Description
7:0	PA_TABLE2[7:0]	0x00	R/W	Power amplifier output power setting 2 Currently used PA output power is selected by FRENDO.PA_POWER[2:0]

**0xDF2D: PA\_TABLE1– PA power setting 1**

Bit	Field Name	Reset	R/W	Description
7:0	PA_TABLE1[7:0]	0x00	R/W	Power amplifier output power setting 1 Currently used PA output power is selected by FRENDO.PA_POWER[2:0]

**0xDF2E: PA\_TABLE0 – PA power setting 0**

Bit	Field Name	Reset	R/W	Description
7:0	PA_TABLE0[7:0]	0xC6	R/W	Power amplifier output power setting 0 Currently used PA output power is selected by FRENDO.PA_POWER[2:0]

**0xDF36: PARTNUM – Chip Identifier**

Bit	Field Name	Reset	R/W	Description
7:0	PARTNUM[7:0]	0x81 <i>CC2510Fx</i> 0x91 <i>CC2511Fx</i>	R	Chip part number

**0xDF37: VERSION – Chip Version**

Bit	Field Name	Reset	R/W	Description
7:0	VERSION[7:0]	0x03	R	Chip version number.

**0xDF38: FREQEST – Frequency Offset Estimate from demodulator**

Bit	Field Name	Reset	R/W	Description
7:0	FREQOFF_EST		R	The estimated frequency offset (two's complement) of the carrier. Resolution is $F_{XTAL}/2^{14}$ (1.5kHz-1.7kHz); range is $\pm 186\text{kHz}$ to $\pm 217\text{kHz}$ , dependent of XTAL frequency. Frequency offset compensation is only supported for FSK and MSK modulation. This register will read 0 when using OOK modulation.

**0xDF39: LQI – Demodulator estimate for Link Quality**

Bit	Field Name	Reset	R/W	Description
7	CRC OK		R	The last CRC comparison matched. Cleared when entering/restarting RX mode.
6:0	LQI_EST[6:0]		R	The Link Quality Indicator estimates how easily a received signal can be demodulated. Calculated over the 64 symbols following the sync word (first 8 packet bytes for 2-ary modulation, first 16 packet bytes for 4-ary modulation).

**0xDF3A: RSSI – Received signal strength indication**

Bit	Field Name	Reset	R/W	Description
7:0	RSSI		R	Received signal strength indicator

**0xDF3B: MARCSTATE – Main Radio Control State Machine state**

Bit	Field Name	Reset	R/W	Description																																																																								
7:5	Reserved		R0																																																																									
4:0	MARC_STATE[4:0]		R	<p>Main Radio Control FSM State</p> <table border="1"> <thead> <tr> <th>Value</th> <th>State name</th> <th>State (Figure 50, page 209)</th> </tr> </thead> <tbody> <tr><td>0 (0x00)</td><td>SLEEP</td><td>SLEEP</td></tr> <tr><td>1 (0x01)</td><td>IDLE</td><td>IDLE</td></tr> <tr><td>2 (0x02)</td><td>XOFF</td><td>XOFF</td></tr> <tr><td>3 (0x03)</td><td>VCOON_MC</td><td>MANCAL</td></tr> <tr><td>4 (0x04)</td><td>REGON_MC</td><td>MANCAL</td></tr> <tr><td>5 (0x05)</td><td>MANCAL</td><td>MANCAL</td></tr> <tr><td>6 (0x06)</td><td>VCOON</td><td>FS_WAKEUP</td></tr> <tr><td>7 (0x07)</td><td>REGON</td><td>FS_WAKEUP</td></tr> <tr><td>8 (0x08)</td><td>STARTCAL</td><td>CALIBRATE</td></tr> <tr><td>9 (0x09)</td><td>BWBOOST</td><td>SETTLING</td></tr> <tr><td>10 (0x0A)</td><td>FS_LOCK</td><td>SETTLING</td></tr> <tr><td>11 (0x0B)</td><td>IFADCON</td><td>SETTLING</td></tr> <tr><td>12 (0x0C)</td><td>ENDCAL</td><td>CALIBRATE</td></tr> <tr><td>13 (0x0D)</td><td>RX</td><td>RX</td></tr> <tr><td>14 (0x0E)</td><td>RX_END</td><td>RX</td></tr> <tr><td>15 (0x0F)</td><td>RX_RST</td><td>RX</td></tr> <tr><td>16 (0x10)</td><td>TXRX_SWITCH</td><td>TXRX_SETTLING</td></tr> <tr><td>17 (0x11)</td><td>RX_OVERFLOW</td><td>RX_OVERFLOW</td></tr> <tr><td>18 (0x12)</td><td>FSTXON</td><td>FSTXON</td></tr> <tr><td>19 (0x13)</td><td>TX</td><td>TX</td></tr> <tr><td>20 (0x14)</td><td>TX_END</td><td>TX</td></tr> <tr><td>21 (0x15)</td><td>RXTX_SWITCH</td><td>RXTX_SETTLING</td></tr> <tr><td>22 (0x16)</td><td>TX_UNDERFLOW</td><td>TX_UNDERFLOW</td></tr> </tbody> </table>	Value	State name	State (Figure 50, page 209)	0 (0x00)	SLEEP	SLEEP	1 (0x01)	IDLE	IDLE	2 (0x02)	XOFF	XOFF	3 (0x03)	VCOON_MC	MANCAL	4 (0x04)	REGON_MC	MANCAL	5 (0x05)	MANCAL	MANCAL	6 (0x06)	VCOON	FS_WAKEUP	7 (0x07)	REGON	FS_WAKEUP	8 (0x08)	STARTCAL	CALIBRATE	9 (0x09)	BWBOOST	SETTLING	10 (0x0A)	FS_LOCK	SETTLING	11 (0x0B)	IFADCON	SETTLING	12 (0x0C)	ENDCAL	CALIBRATE	13 (0x0D)	RX	RX	14 (0x0E)	RX_END	RX	15 (0x0F)	RX_RST	RX	16 (0x10)	TXRX_SWITCH	TXRX_SETTLING	17 (0x11)	RX_OVERFLOW	RX_OVERFLOW	18 (0x12)	FSTXON	FSTXON	19 (0x13)	TX	TX	20 (0x14)	TX_END	TX	21 (0x15)	RXTX_SWITCH	RXTX_SETTLING	22 (0x16)	TX_UNDERFLOW	TX_UNDERFLOW
Value	State name	State (Figure 50, page 209)																																																																										
0 (0x00)	SLEEP	SLEEP																																																																										
1 (0x01)	IDLE	IDLE																																																																										
2 (0x02)	XOFF	XOFF																																																																										
3 (0x03)	VCOON_MC	MANCAL																																																																										
4 (0x04)	REGON_MC	MANCAL																																																																										
5 (0x05)	MANCAL	MANCAL																																																																										
6 (0x06)	VCOON	FS_WAKEUP																																																																										
7 (0x07)	REGON	FS_WAKEUP																																																																										
8 (0x08)	STARTCAL	CALIBRATE																																																																										
9 (0x09)	BWBOOST	SETTLING																																																																										
10 (0x0A)	FS_LOCK	SETTLING																																																																										
11 (0x0B)	IFADCON	SETTLING																																																																										
12 (0x0C)	ENDCAL	CALIBRATE																																																																										
13 (0x0D)	RX	RX																																																																										
14 (0x0E)	RX_END	RX																																																																										
15 (0x0F)	RX_RST	RX																																																																										
16 (0x10)	TXRX_SWITCH	TXRX_SETTLING																																																																										
17 (0x11)	RX_OVERFLOW	RX_OVERFLOW																																																																										
18 (0x12)	FSTXON	FSTXON																																																																										
19 (0x13)	TX	TX																																																																										
20 (0x14)	TX_END	TX																																																																										
21 (0x15)	RXTX_SWITCH	RXTX_SETTLING																																																																										
22 (0x16)	TX_UNDERFLOW	TX_UNDERFLOW																																																																										

### 0xDF3C: PKTSTATUS – Current GDOx status and packet status

Bit	Field Name	Reset	R/W	Description
7	CRC_OK	0	R	The last CRC comparison matched. Cleared when entering/restarting RX mode.
6	CS	0	R	Carrier sense
5	PQT_REACHED	0	R	Preamble Quality reached
4	CCA	0	R	Clear channel assessment
3	SFD	0	R	Start of Frame Delimiter found
2:0	-	000	R0	Not used.

### 0xDF3D: VCO\_VC\_DAC – Current setting from PLL calibration module

Bit	Field Name	Reset	R/W	Description
7:0	VCO_VC_DAC[7:0]		R	Status register for test only.



## 16 Voltage Regulators

The *CC2510Fx/CC2511Fx* includes a low drop-out voltage regulator. This is used to provide a 1.8 V power supply to the *CC2510Fx/CC2511Fx* digital power supply. The voltage regulator should not be used to provide power to external circuits because of limited power sourcing capability and also due to noise considerations.

The voltage regulator input pin AVDD\_DREG is to be connected to the unregulated 2.0 V to 3.6 V power supply. The output of the digital regulator is connected internally in the *CC2510Fx/CC2511Fx* to the digital power supply.

## 17 Radio Test Output signals

For debug and test purposes, a number of internal status signals in the radio may be output on the port pins P1\_7 – P1\_5. This debug option is controlled through the RF registers IOCFG2–IOCFG0 . Table 69

The voltage regulator requires an external decoupling capacitor connected to the DCOUPL pin as described in section 11 on page 31.

### 16.1 Voltage Regulator Power-on

The voltage regulator is disabled when the *CC2510Fx/CC2511Fx* is placed in power modes PM2 or PM3 (see section 13.10). When the voltage regulator is disabled, register and RAM contents will be retained while the unregulated 2.0 V - 3.6 V power supply is present.

shows the value written to IOCFGx.GDOx\_CFG[5:0] with the corresponding internal signals that will be output in each case.

GDO0_CFG[5:0] GDO1_CFG[5:0] GDO2_CFG[5:0]	Description
0-7	Not in use
8	Preamble Quality Reached. Asserts when the PQI is above the programmed PQT value.
9	Clear channel assessment. High when RSSI level is below threshold (dependent on the current CCA_MODE setting)
10	Lock detector output
11	Serial Clock. Synchronous to the data in synchronous serial mode. Data is set up on the falling edge and is read on the rising edge of SERIAL_CLK.
12	Serial Synchronous Data Output. Used for synchronous serial mode. The MCU must read DO on the rising edge of SERIAL_CLK. Data is set up on the falling edge by CC1100.
13	Serial transparent Data Output. Used for asynchronous serial mode.
14	Carrier sense. High if RSSI level is above threshold.
15	CRC OK. The last CRC comparison matched. Cleared when entering/restarting RX mode.
16	ADC I/Q – serialized
17	Decimation filter output I/Q + channel filter I/Q + CORDIC + GAIN
18	Demodulator backend key signals (PSK)
19	Demodulator backend key signals (FSK)
20	Data filter output
24	Not in use
22	RX_HARD_DATA[1]
23	RX_HARD_DATA[0]
24	FPLL
25	CLK_PRE
26	VCO_CURR_COMP
27	PA_PD
28	LNA_PD
29	RX_SYMBOL_TICK
30-46	Not in use
47	HW to 0 (HW1 achieved with _INV signal)
48-63	Not in use

**Table 69: Debug output signals**

## **18 Evaluation Software**

Chipcon provides users of *CC2510Fx/CC2511Fx* with a software program, SmartRF® Studio, which may be used for radio performance and functionality evaluation. SmartRF® Studio runs on Microsoft Windows 95/98 and Microsoft Windows NT/XP/2000.

SmartRF® Studio can be downloaded from Chipcon's web page:

<http://www.ti.com/lpw>

<http://www.chipcon.com>

## 19 Register overview

DPH0 (0x83) – Data Pointer 0 High Byte.....	38
DPL0 (0x82) – Data Pointer 0 Low Byte.....	38
DPH1 (0x85) – Data Pointer 1 High Byte.....	38
DPL1 (0x84) – Data Pointer 1 Low Byte.....	38
DPS (0x92) – Data Pointer Select.....	38
MPAGE (0x93)– Memory Page Select.....	39
PSW (0xD0) – Program Status Word.....	43
ACC (0xE0) – Accumulator.....	43
B (0xF0) – B Register.....	44
SP (0x81) – Stack Pointer.....	44
IEN0 (0xA8) – Interrupt Enable 0 Register.....	51
IEN1 (0xB8) – Interrupt Enable 1 Register.....	52
IEN2 (0x9A) – Interrupt Enable 2 Register.....	53
TCON (0x88) – Interrupt Flag.....	55
S0CON (0x98) – Interrupt Flag 2.....	56
S1CON (0x9B) – Interrupt Flag 3.....	56
IRCON (0xC0) – Interrupt Flag 4.....	57
IRCON2 (0xE8) – Interrupt Flag 5.....	58
IP1 (0xB9) – Interrupt Priority 1.....	59
IP0 (0xA9) – Interrupt Priority 0.....	59
MEMCTR (0xC7) – Memory Arbiter Control.....	65
P0 (0x80) – Port 0.....	71
P1 (0x90) – Port 1.....	71
P2 (0xA0) – Port 2.....	71
PERCFG (0xF1) – Peripheral Control.....	71
ADCCFG (0xF2) – ADC Input Configuration.....	72
P0SEL (0xF3) – Port 0 Function Select.....	72
P1SEL (0xF4) – Port 1 Function Select.....	73
P2SEL (0xF5) – Port 2 Function Select.....	74
P0DIR (0xFD) – Port 0 Direction.....	75
P1DIR (0xFE) – Port 1 Direction.....	76
P2DIR (0xFF) – Port 2 Direction.....	77
P0INP (0x8F) – Port 0 Input Mode.....	78
P1INP (0xF6) – Port 1 Input Mode.....	79
P2INP (0xF7) – Port 2 Input Mode.....	80
P0IFG (0x89) – Port 0 Interrupt Status Flag.....	81
P1IFG (0x8A) – Port 1 Interrupt Status Flag.....	81
P2IFG (0x8B) – Port 2 Interrupt Status Flag.....	81
PICTL (0x8C) – Port Interrupt Control.....	82
P1IEN (0x8D) – Port 1 Interrupt Mask.....	83
DMAARM (0xD6) – DMA Channel Arm.....	93
DMAREQ (0xD7) – DMA Channel Start Request and Status.....	94
DMA0CFGH (0xD5) – DMA Channel 0 Configuration Address High Byte.....	94
DMA0CFGL (0xD4) – DMA Channel 0 Configuration Address Low Byte.....	94
DMA1CFGH (0xD3) – DMA Channel 1-4 Configuration Address High Byte.....	95
DMA1CFGL (0xD2) – DMA Channel 1-4 Configuration Address Low Byte.....	95
DMAIRQ (0xD1) – DMA Interrupt Flag.....	95
ENDIAN (0x95) – USB Endianess Control ( <b>CC2511Fx</b> ).....	96
T1CNTH (0xE3) – Timer 1 Counter High.....	106
T1CNTL (0xE2) – Timer 1 Counter Low.....	106

T1CTL (0xE4) – Timer 1 Control and Status.....	106
T1CCTL0 (0xE5) – Timer 1 Channel 0 Capture/Compare Control.....	107
T1CC0H (0xDB) – Timer 1 Channel 0 Capture/Compare Value High .....	107
T1CC0L (0xDA) – Timer 1 Channel 0 Capture/Compare Value Low .....	107
T1CCTL1 (0xE6) – Timer 1 Channel 1 Capture/Compare Control.....	108
T1CC1H (0xDD) – Timer 1 Channel 1 Capture/Compare Value High .....	108
T1CC1L (0xDC) – Timer 1 Channel 1 Capture/Compare Value Low .....	109
T1CCTL2 (0xE7) – Timer 1 Channel 2 Capture/Compare Control.....	109
T1CC2H (0xDF) – Timer 1 Channel 2 Capture/Compare Value High.....	109
T1CC2L (0xDE) – Timer 1 Channel 2 Capture/Compare Value Low.....	110
T2CTL (0x9E) – Timer 2 Control.....	112
T2CT (0x9C) – Timer 2 Count.....	112
T2PR (0x9D) – Timer 2 Prescaler.....	112
WORTIME0 (0xA5) – Sleep Timer Low Byte.....	114
WORTIME1 (0xA6) – Sleep Timer High Byte .....	114
WOREVT1 (0xA4) – Sleep Timer Event0 Timeout High .....	114
WOREVT0 (0xA3) – Sleep Timer Event0 Timeout Low .....	114
WORCTL (0xA2) – Sleep Timer Control.....	115
WORIRQ (0xA1) – Sleep Timer Interrupt Control.....	115
T3CNT (0xCA) – Timer 3 Counter.....	120
T3CTL (0xCB) – Timer 3 Control .....	120
T3CCTL0 (0xCC) – Timer 3 Channel 0 Capture/Compare Control.....	121
T3CC0 (0xCD) – Timer 3 Channel 0 Capture/Compare Value .....	121
T3CCTL1 (0xCE) – Timer 3 Channel 1 Capture/Compare Control .....	122
T3CC1 (0xCF) – Timer 3 Channel 1 Capture/Compare Value.....	122
T4CNT (0xEA) – Timer 4 Counter .....	122
T4CTL (0xEB) – Timer 4 Control .....	123
T4CCTL0 (0xEC) – Timer 4 Channel 0 Capture/Compare Control .....	124
T4CC0 (0xED) – Timer 4 Channel 0 Capture/Compare Value .....	124
T4CCTL1 (0xEE) – Timer 4 Channel 1 Capture/Compare Control .....	125
T4CC1 (0xEF) – Timer 4 Channel 1 Capture/Compare Value .....	125
TIMIF (0xD8) – Timers 1/3/4 Interrupt Mask/Flag .....	126
ADCL (0xBA) – ADC Data Low.....	130
ADCH (0xBB) – ADC Data High.....	130
ADCCON1 (0xB4) – ADC Control 1 .....	130
ADCCON2 (0xB5) – ADC Control 2 .....	131
ADCCON3 (0xB6) – ADC Control 3 .....	132
RNDL (0xBC) – Random Number Generator Data Low Byte .....	134
RNDH (0xBD) – Random Number Generator Data High Byte.....	134
ENCCS (0xB3) – Encryption Control and Status .....	139
ENCDI (0xB1) – Encryption Input Data.....	139
ENCDO (0xB2) – Encryption Output Data.....	139
PCON (0x87) – Power Mode Control .....	142
SLEEP (0xBE) – Sleep Mode Control .....	142
CLKCON (0xC6) – Clock Control.....	143
WDCTL (0xC9) – Watchdog Timer Control .....	146
U0CSR (0x86) – USART 0 Control and Status .....	152
U0UCR (0xC4) – USART 0 UART Control .....	153
U0GCR (0xC5) – USART 0 Generic Control.....	154
U0DBUF (0xC1) – USART 0 Receive/Transmit Data Buffer.....	154
U0BAUD (0xC2) – USART 0 Baud Rate Control.....	154
U1CSR (0xF8) – USART 1 Control and Status .....	155
U1UCR (0xFB) – USART 1 UART Control .....	156

U1GCR (0xFC) – USART 1 Generic Control.....	157
U1DBUF (0xF9) – USART 1 Receive/Transmit Data Buffer .....	157
U1BAUD (0xFA) – USART 1 Baud Rate Control .....	157
FCTL (0xAE) – Flash Control .....	189
FWDATA (0xAF) – Flash Write Data.....	189
FADDRH (0xAD) – Flash Address High Byte .....	189
FADDRL (0xAC) – Flash Address Low Byte .....	189
FWT (0xAB) – Flash Write Timing .....	189
RFIF (0xE9) – RF Interrupt Flags .....	194
RFIM (0x91) – RF Interrupt Mask.....	195

## 20 Package Description (QLP 36)

All dimensions are in millimeters, angles in degrees. NOTE: The *CC2510Fx/CC2511Fx* is available in RoHS lead-free package only. Compliant with JEDEC: MO-220.

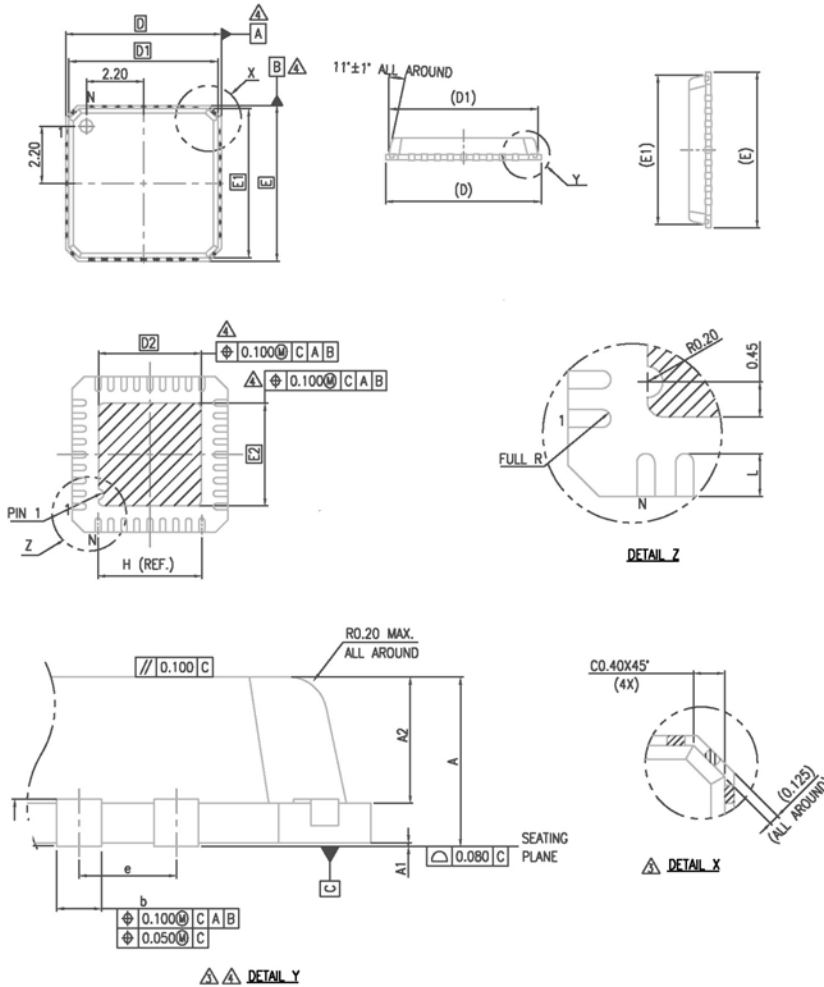
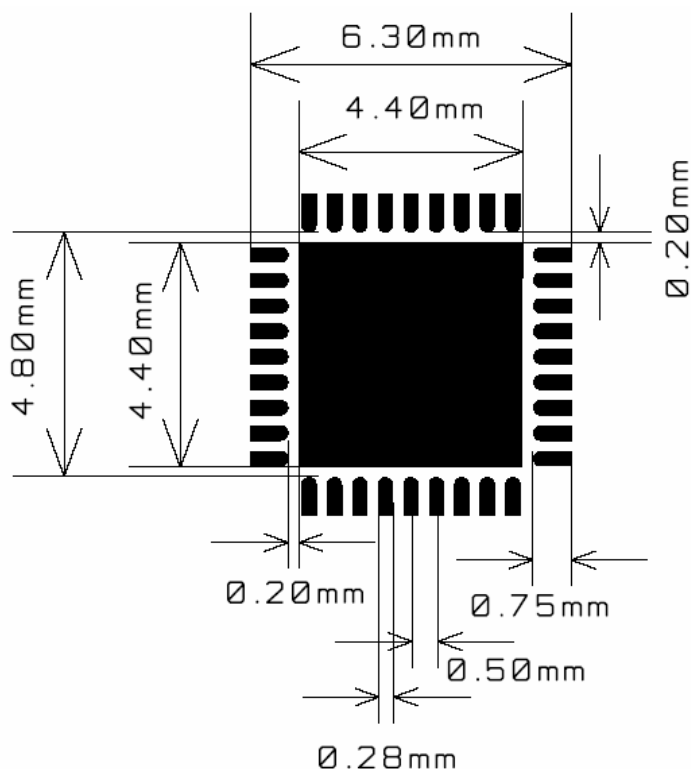

Figure 58: Package dimensions drawing

Quad Leadless Package (QLP)													
		A	A1	A2	D	D1	E	E1	e	b	L	D2	E2
QLP36	Min	0.80	0.005	0.60	5.90	5.65	5.90	5.65	0.50	0.18	0.45	1.75	1.75
		0.85	0.025	0.65	6.00	5.75	6.00	5.75		0.23	0.55		
	Max	0.90	0.045	0.70	6.10	5.85	6.10	5.85		0.30	0.65	4.40	4.40
The overall package height is 0.85 +/- 0.05													
All dimensions in mm													

Table 70: Package dimensions

## 20.1 Recommended PCB layout for package (QLP 36)



**Figure 59: Recommended PCB layout for QLP 36 package**

Note: The figure is an illustration only and not to scale. There are nine 14 mil diameter via holes distributed symmetrically in the ground pad under the package. See also the *CC2510Fx* EM reference design.

## 20.2 Package thermal properties

Thermal resistance	
Air velocity [m/s]	0
R <sub>th,j-a</sub> [K/W]	32

**Table 71: Thermal properties of QLP 36 package**

## 20.3 Soldering information

The recommendations for lead-free reflow in IPC/JEDEC J-STD-020C should be followed.

## 20.4 Tray specification

Tray Specification				
Package	Tray Length	Tray Width	Tray Height	Units per Tray
QLP 36	322.6 mm	135.9 mm	7.62 mm	490

**Table 72: Tray specification**



## 20.5 Carrier tape and reel specification

Carrier tape and reel is in accordance with EIA Specification 481.

Tape and Reel Specification						
Package	Carrier Tape Width	Component Pitch	Hole Pitch	Reel Diameter	Reel Hub Diameter	Units per Reel
QLP 36	16 mm	12 mm	4 mm	13 inches	7 inches	2500

**Table 73: Carrier tape and reel specification**

## 21 Ordering Information

Ordering part number	Description	Minimum Order Quantity
CC2510F8RSP	8 kB FLASH, 1 kB RAM, System-on-Chip RF Transceiver. QLP36 package, RoHS compliant Pb-free assembly, Tray with 490 pcs per tray.	490
CC2510F8RSPR	8 kB FLASH, 1 kB RAM, System-on-Chip RF Transceiver. QLP36 package, RoHS compliant Pb-free assembly, T&R with 2500 pcs per reel.	2500
CC2510F16RSP	16 kB FLASH, 2 kB RAM, System-on-Chip RF Transceiver. QLP36 package, RoHS compliant Pb-free assembly, Tray with 490 pcs per tray.	490
CC2510F16RSPR	16 kB FLASH, 2 kB RAM, System-on-Chip RF Transceiver. QLP36 package, RoHS compliant Pb-free assembly, T&R with 2500 pcs per reel.	2500
CC2510F32RSP	32 kB FLASH, 4 kB RAM, System-on-Chip RF Transceiver. QLP36 package, RoHS compliant Pb-free assembly, Tray with 490 pcs per tray.	490
CC2510F32RSPR	32 kB FLASH, 4 kB RAM, System-on-Chip RF Transceiver. QLP36 package, RoHS compliant Pb-free assembly, T&R with 2500 pcs per reel.	2500
CC2511F8RSP	8 kB FLASH, 1 kB RAM, full-speed USB, System-on-Chip RF Transceiver. QLP36 package, RoHS compliant Pb-free assembly, Tray with 490 pcs per tray.	490
CC2511F8RSPR	8 kB FLASH, 1 kB RAM, full-speed USB, System-on-Chip RF Transceiver. QLP36 package, RoHS compliant Pb-free assembly, T&R with 2500 pcs per reel.	2500
CC2511F16RSP	16 kB FLASH, 2 kB RAM, full-speed USB, System-on-Chip RF Transceiver. QLP36 package, RoHS compliant Pb-free assembly, Tray with 490 pcs per tray.	490
CC2511F16RSPR	16 kB FLASH, 2 kB RAM, full-speed USB, System-on-Chip RF Transceiver. QLP36 package, RoHS compliant Pb-free assembly, T&R with 2500 pcs per reel.	2500
CC2511F32RSP	32 kB FLASH, 4 kB RAM, full-speed USB, System-on-Chip RF Transceiver. QLP36 package, RoHS compliant Pb-free assembly, Tray with 490 pcs per tray.	490
CC2511F32RSPR	32 kB FLASH, 4 kB RAM, full-speed USB, System-on-Chip RF Transceiver. QLP36 package, RoHS compliant Pb-free assembly, T&R with 2500 pcs per reel.	2500
CC2510-CC2511DK	CC2510Fx and CC2511Fx Development Kit	1

**Table 74: Ordering Information**

## 22 General Information

### 22.1 Document History

Revision	Date	Description/Changes
1.0	2005-11-17	First release, preliminary
1.01	2006-05-11	Preliminary status updated
1.1	2006-05-30	CC2511Fx, CC2510F8 and CC2510F16 added to datasheet.
1.2	2006-07-06	Changed recommended PCB layout for package (QLP 36), fig 59

**Table 75: Document history**

### 22.2 Product Status Definitions

Data Sheet Identification	Product Status	Definition
Advance Information	Planned or Under Development	This data sheet contains the design specifications for product development. Specifications may change in any manner without notice.
Preliminary	Engineering Samples and Pre-Production Prototypes	This data sheet contains preliminary data, and supplementary data will be published at a later date. Chipcon reserves the right to make changes at any time without notice in order to improve design and supply the best possible product. The product at this point is not yet fully qualified.
No Identification Noted	Full Production	This data sheet contains the final specifications. Chipcon reserves the right to make changes at any time without notice in order to improve design and supply the best possible product.
Obsolete	Not In Production	This data sheet contains specifications on a product that has been discontinued by Chipcon. The data sheet is printed for reference information only.

**Table 76: Product Status Definitions**

## 23 Address Information

Texas Instruments Norway AS  
Gaustadalléen 21  
N-0349 Oslo  
NORWAY  
Tel: +47 22 95 85 44  
Fax: +47 22 95 85 46  
Web site: <http://www.ti.com/lpw>

## 24 TI Worldwide Technical Support

### Internet

TI Semiconductor Product Information Center Home Page: [support.ti.com](http://support.ti.com)  
TI Semiconductor KnowledgeBase Home Page: [support.ti.com/sc/knowledgebase](http://support.ti.com/sc/knowledgebase)

### Product Information Centers

#### Americas

**Phone:** +1(972) 644-5580  
**Fax:** +1(972) 927-6377  
**Internet/Email:** [support.ti.com/sc/pic/americas.htm](http://support.ti.com/sc/pic/americas.htm)

#### Europe, Middle East and Africa

**Phone:**  
Belgium (English) +32 (0) 27 45 54 32  
Finland (English) +358 (0) 9 25173948  
France +33 (0) 1 30 70 11 64  
Germany +49 (0) 8161 80 33 11  
Israel (English) 180 949 0107  
Italy 800 79 11 37  
Netherlands (English) +31 (0) 546 87 95 45  
Russia +7 (4) 95 98 10 701  
Spain +34 902 35 40 28  
Sweden (English) +46 (0) 8587 555 22  
United Kingdom +44 (0) 1604 66 33 99  
**Fax:** +49 (0) 8161 80 2045  
**Internet:** [support.ti.com/sc/pic/euro.htm](http://support.ti.com/sc/pic/euro.htm)

#### Japan

**Fax** International +81-3-3344-5317  
Domestic 0120-81-0036  
**Internet/Email** International [support.ti.com/sc/pic/japan.htm](http://support.ti.com/sc/pic/japan.htm)  
Domestic [www.tij.co.jp/pic](http://www.tij.co.jp/pic)

**Asia**

<b>Phone</b>	International	+886-2-23786800
	Domestic	<u>Toll-Free Number</u>
	Australia	1-800-999-084
	China	800-820-8682
	Hong Kong	800-96-5941
	India	+91-80-51381665 (Toll)
	Indonesia	001-803-8861-1006
	Korea	080-551-2804
	Malaysia	1-800-80-3973
	New Zealand	0800-446-934
	Philippines	1-800-765-7404
	Singapore	800-886-1028
	Taiwan	0800-006800
	Thailand	001-800-886-0010
	<b>Fax</b>	+886-2-2378-6808
<b>Email</b>	tiasia@ti.com or ti-china@ti.com	
<b>Internet</b>	support.ti.com/sc/pic/asia.htm	

## IMPORTANT NOTICE

Texas Instruments Incorporated and its subsidiaries (TI) reserve the right to make corrections, modifications, enhancements, improvements, and other changes to its products and services at any time and to discontinue any product or service without notice. Customers should obtain the latest relevant information before placing orders and should verify that such information is current and complete. All products are sold subject to TI's terms and conditions of sale supplied at the time of order acknowledgment.

TI warrants performance of its hardware products to the specifications applicable at the time of sale in accordance with TI's standard warranty. Testing and other quality control techniques are used to the extent TI deems necessary to support this warranty. Except where mandated by government requirements, testing of all parameters of each product is not necessarily performed.

TI assumes no liability for applications assistance or customer product design. Customers are responsible for their products and applications using TI components. To minimize the risks associated with customer products and applications, customers should provide adequate design and operating safeguards.

TI does not warrant or represent that any license, either express or implied, is granted under any TI patent right, copyright, mask work right, or other TI intellectual property right relating to any combination, machine, or process in which TI products or services are used. Information published by TI regarding third-party products or services does not constitute a license from TI to use such products or services or a warranty or endorsement thereof. Use of such information may require a license from a third party under the patents or other intellectual property of the third party, or a license from TI under the patents or other intellectual property of TI.

Reproduction of information in TI data books or data sheets is permissible only if reproduction is without alteration and is accompanied by all associated warranties, conditions, limitations, and notices. Reproduction of this information with alteration is an unfair and deceptive business practice. TI is not responsible or liable for such altered documentation.

Resale of TI products or services with statements different from or beyond the parameters stated by TI for that product or service voids all express and any implied warranties for the associated TI product or service and is an unfair and deceptive business practice. TI is not responsible or liable for any such statements.

Following are URLs where you can obtain information on other Texas Instruments products and application solutions:

<b>Products</b>		<b>Applications</b>	
Amplifiers	<a href="http://amplifier.ti.com">amplifier.ti.com</a>	Audio	<a href="http://www.ti.com/audio">www.ti.com/audio</a>
Data Converters	<a href="http://dataconverter.ti.com">dataconverter.ti.com</a>	Automotive	<a href="http://www.ti.com/automotive">www.ti.com/automotive</a>
DSP	<a href="http://dsp.ti.com">dsp.ti.com</a>	Broadband	<a href="http://www.ti.com/broadband">www.ti.com/broadband</a>
Interface	<a href="http://interface.ti.com">interface.ti.com</a>	Digital Control	<a href="http://www.ti.com/digitalcontrol">www.ti.com/digitalcontrol</a>
Logic	<a href="http://logic.ti.com">logic.ti.com</a>	Military	<a href="http://www.ti.com/military">www.ti.com/military</a>
Power Mgmt	<a href="http://power.ti.com">power.ti.com</a>	Optical Networking	<a href="http://www.ti.com/opticalnetwork">www.ti.com/opticalnetwork</a>
Microcontrollers	<a href="http://microcontroller.ti.com">microcontroller.ti.com</a>	Security	<a href="http://www.ti.com/security">www.ti.com/security</a>
Low Power Wireless	<a href="http://www.ti.com/lpw">www.ti.com/lpw</a>	Telephony	<a href="http://www.ti.com/telephony">www.ti.com/telephony</a>
		Video & Imaging	<a href="http://www.ti.com/video">www.ti.com/video</a>
		Wireless	<a href="http://www.ti.com/wireless">www.ti.com/wireless</a>

Mailing Address: Texas Instruments  
Post Office Box 655303 Dallas, Texas 75265